

19-IN. ELECTRONIC CASE, TYPE 1



INDUSTRY STANDARDS

NEMA Type 1
EIA 310-D / IEC 297-1
IEC 60529, IP20

APPLICATION

Primarily used to house lab electronics, lightweight Electronic Cases accommodate 19-in. sub-racks, chassis and panels in a rigid ventilated case with integral handles.

FEATURES

- Aluminum extrusions attach to front and rear frames to create a rigid supporting framework
- Sides on 3U and 4U tall cases are aluminum extrusions with integral carrying handle. 6U tall cases have steel (1.5-mm) sides with recessed handles. 9U and 12U tall cases have 1.5-mm aluminum sides with recessed handles.
- Removable top and bottom covers attach directly to the case framework
- Bottom cover has multiple rows of slots for ventilation
- Rear cover has ventilation louvers
- Covers are 1-mm steel on 3U, 4U, 6U tall cases and 1-mm aluminum on 9U and 12U tall cases. Covers include grounding provisions.
- Case framework is assembled with rear cover installed
- Top cover, bottom cover, anti-skid feet and mounting hardware are included

SPECIFICATIONS

- One piece aluminum die-cast frame on front and rear
- 19-in. rack-mounting provisions on both front and rear frame comply with EIA 310-D / IEC 297-1 wide spacing
- 9-mm square holes accommodate cage nuts for mounting

FINISH

Framework and rear cover have a stone-gray textured finish (RAL 7030). Top and bottom covers and metal sides have a light-gray textured finish (RAL 7035).

ACCESSORIES

Hardware Kits
Slide Rails

BULLETIN: DEC1

Standard Product

Catalog Number	AxBxC mm	AxBxC in.	F (mm)	F (in.)
EEC3U5250	166 x 520 x 500	6.54 x 20.47 x 19.69	133	5.24
EEC4U5250	210 x 520 x 500	8.27 x 20.47 x 19.69	178	7.01
EEC6U5260	299 x 520 x 600	11.77 x 20.47 x 23.62	267	10.51
EEC9U5260	433 x 520 x 600	17.05 x 20.47 x 23.62	400	15.75
EEC12U5260	566 x 520 x 600	22.28 x 20.47 x 23.62	533	20.98

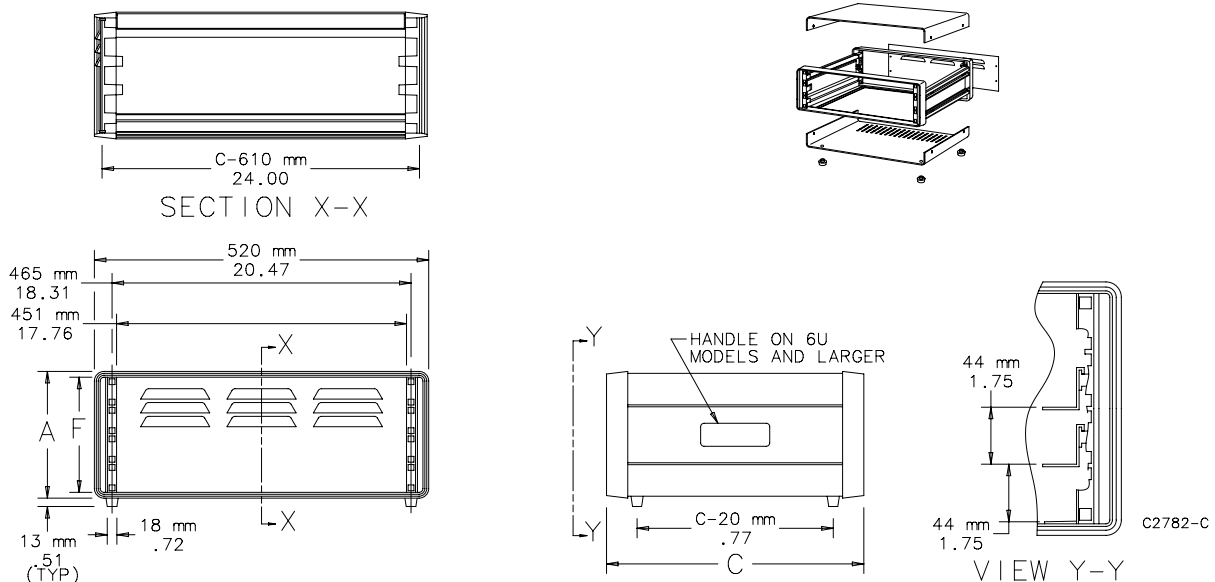

SLIDE RAILS FOR ELECTRONIC CASE

Slide Rails support a 19-in. subrack or chassis when installed in an electronic case. Rails attach to protrusions on the inside front and back castings of the case framework. They are positionable in increments of 1.75 in. (44 mm) vertically. Slide rails are aluminum extrusions with a clear anodized finish, which snap into place. No mounting hardware is required.

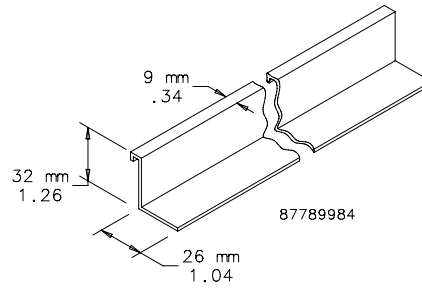

BULLETIN: DEC1

Catalog Number	Fits Case	Package Includes
EECCR50	500-mm deep	1 rail
EECCR60	600-mm deep	1 rail

HARDWARE KITS FOR ELECTRONIC CASE

Use to mount Electronic Case on rack angles with 9-mm square holes.

BULLETIN: DACCY

Catalog Number	Description	Package Includes	Package Qty.
ECNSM6	M6 fastener package	Pan head Posidrive plated M6 x 16 screws, ABS black plastic cup washers and plated cage nuts	8
PM5CN	M5 cage nut package	M5 plated cage nuts	50
ASM5	M5 screw package	Pan head combination screws	20