

Benutzeranleitung
3 / 6 HE, 36 TE
Baugruppenträger
SNCF, geschirmt

User Manual
3 / 6 U, 36 HP
Subrack
SNCF, shielded

Instruction utilisateur
3 / 6 U, 36 F
Bacs à cartes
SNCF, blindés

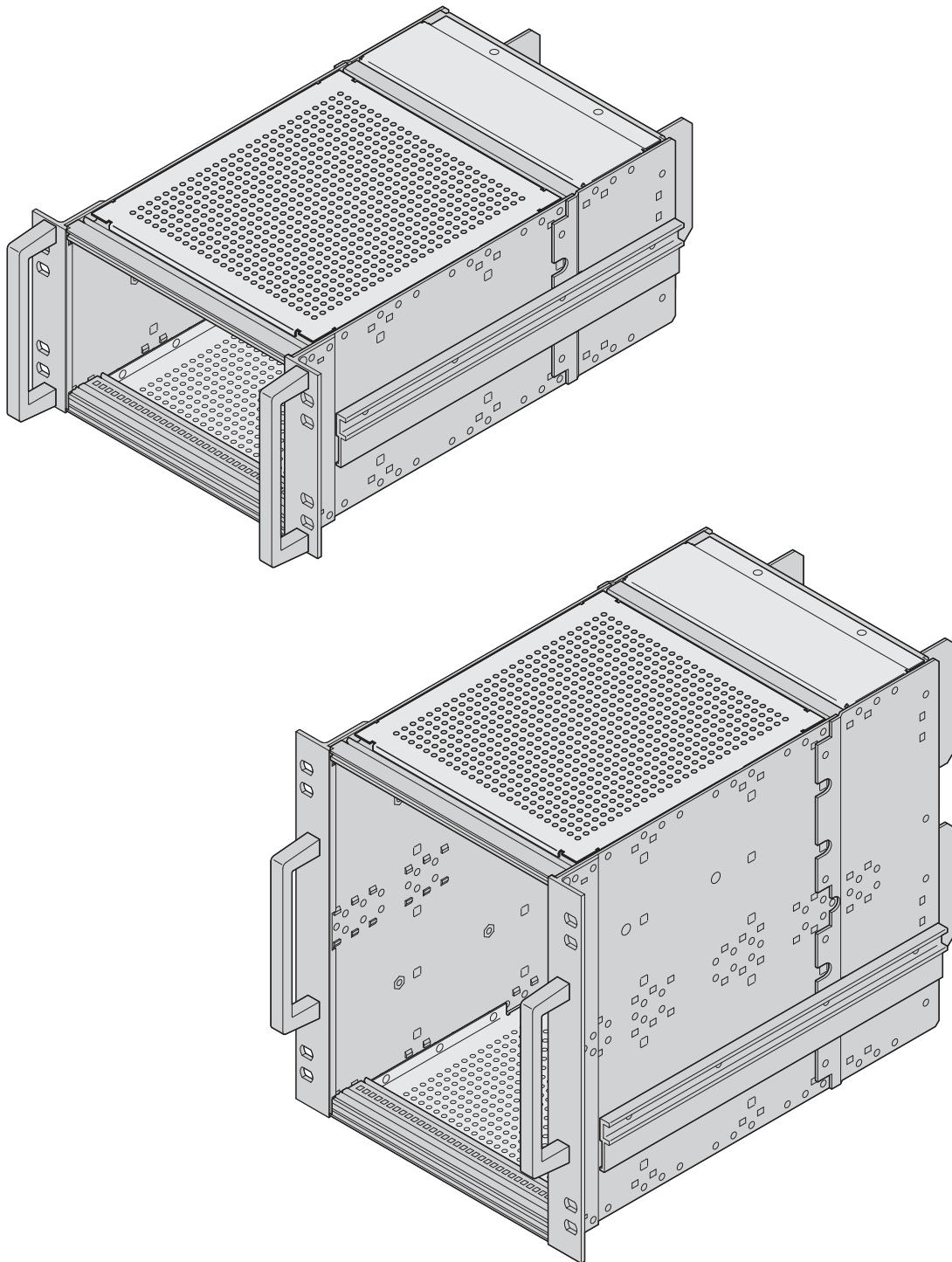

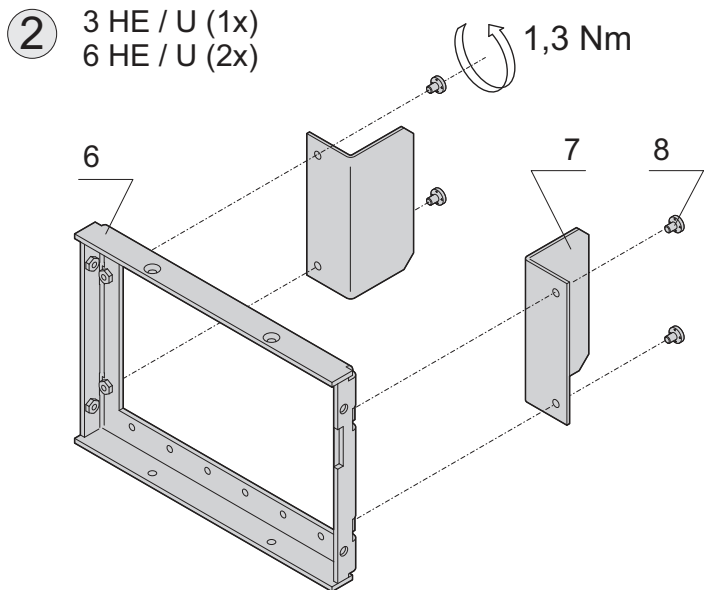
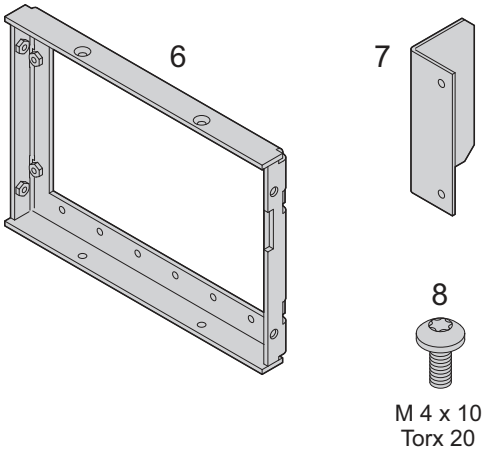
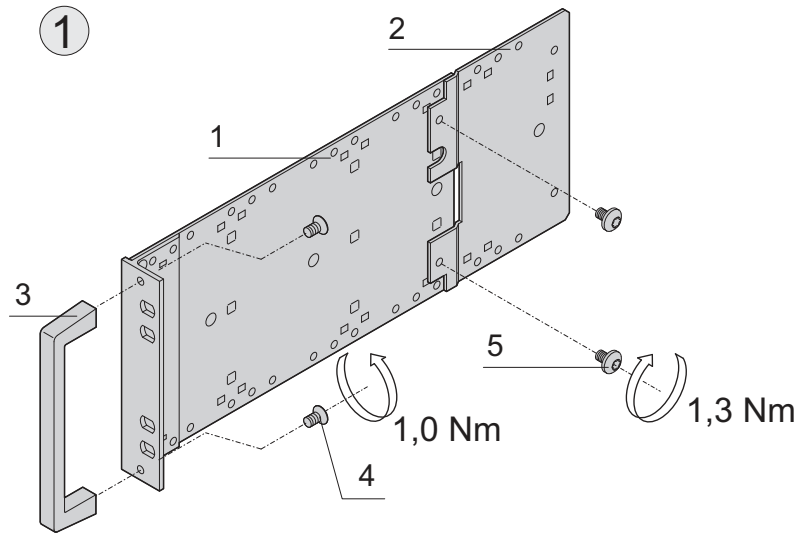
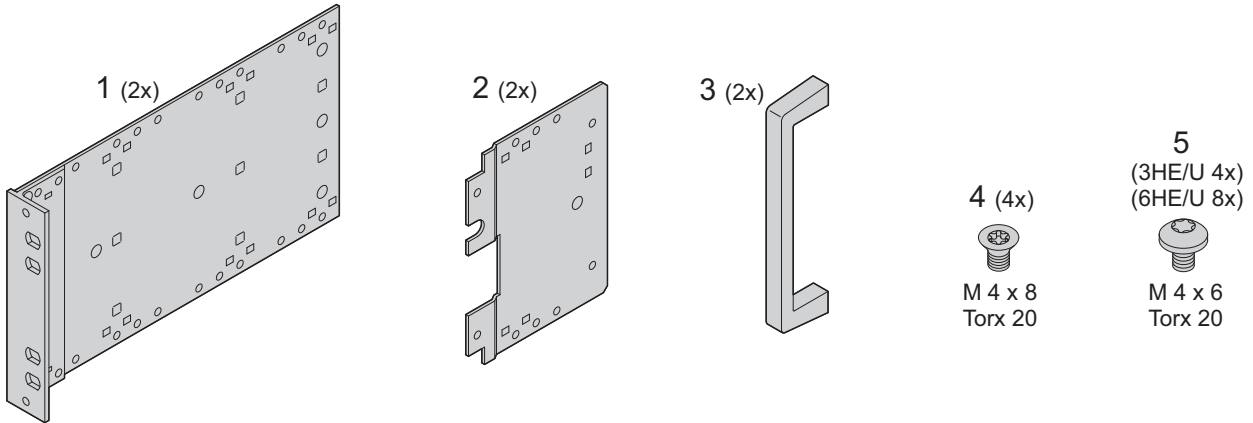

	6	7	8
3 HE / U	1x	2x	4x
6 HE / U	2x	4x	8x

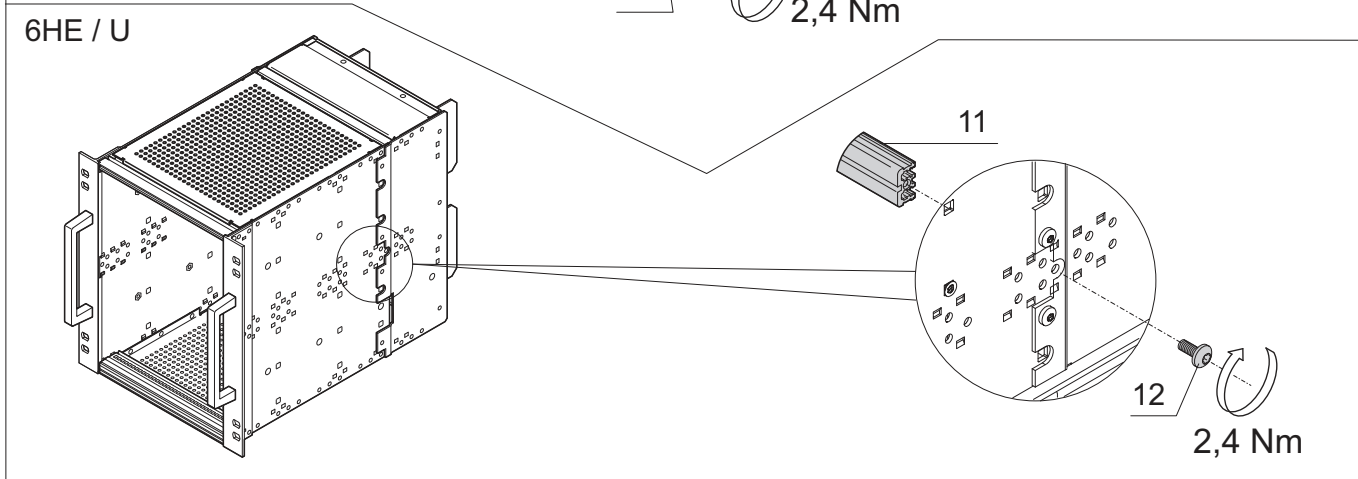
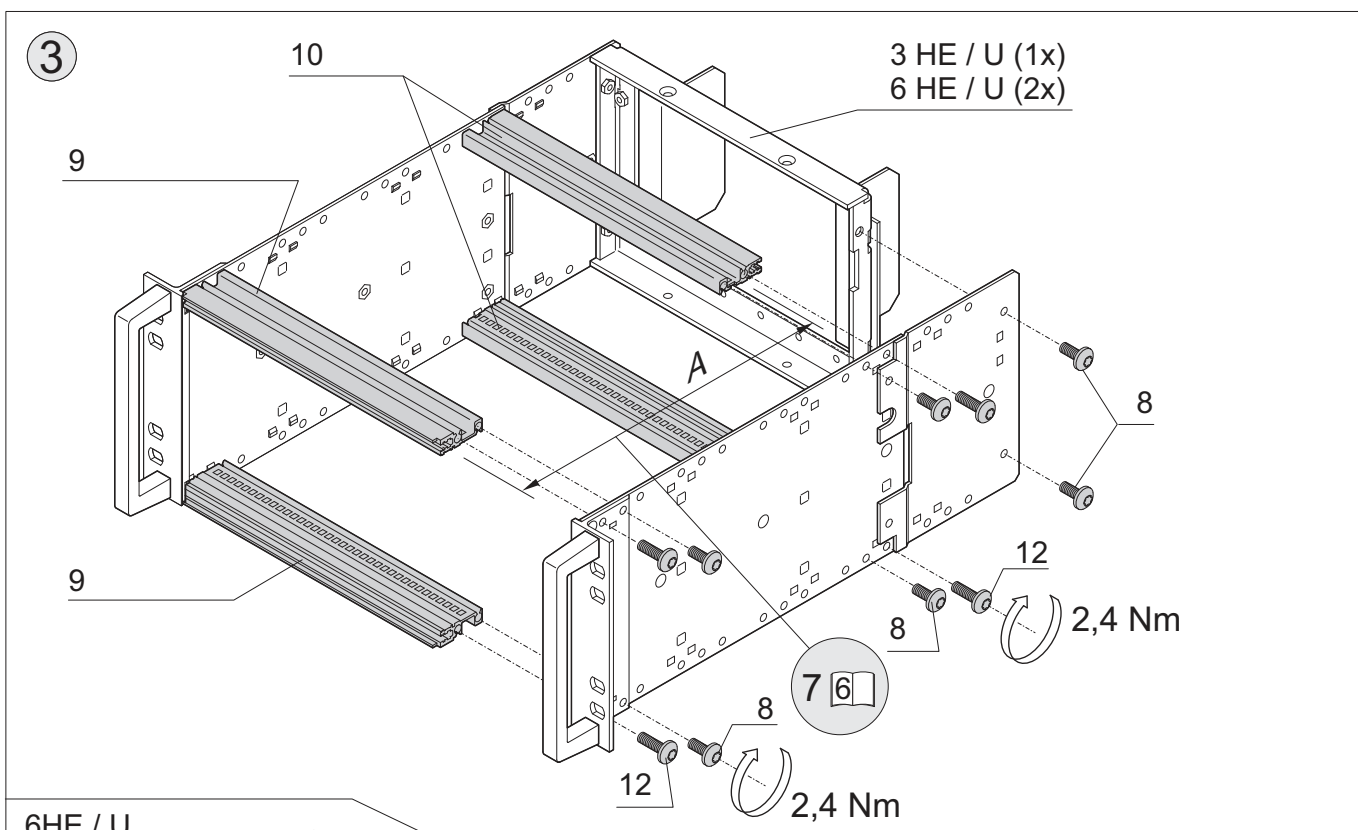
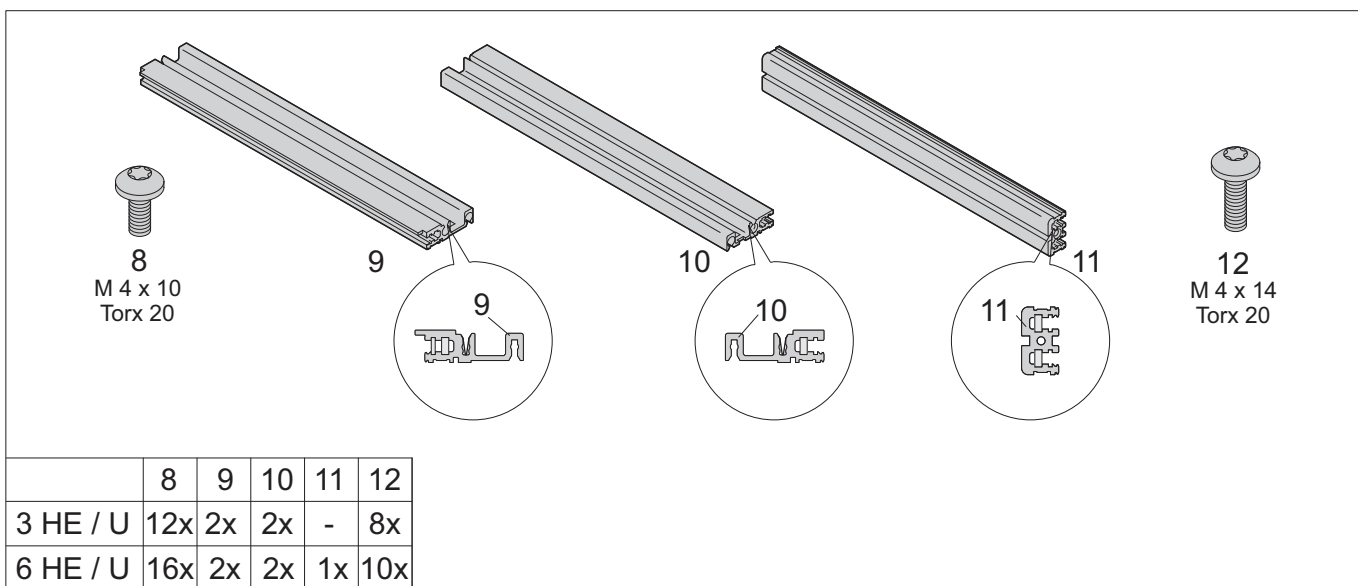

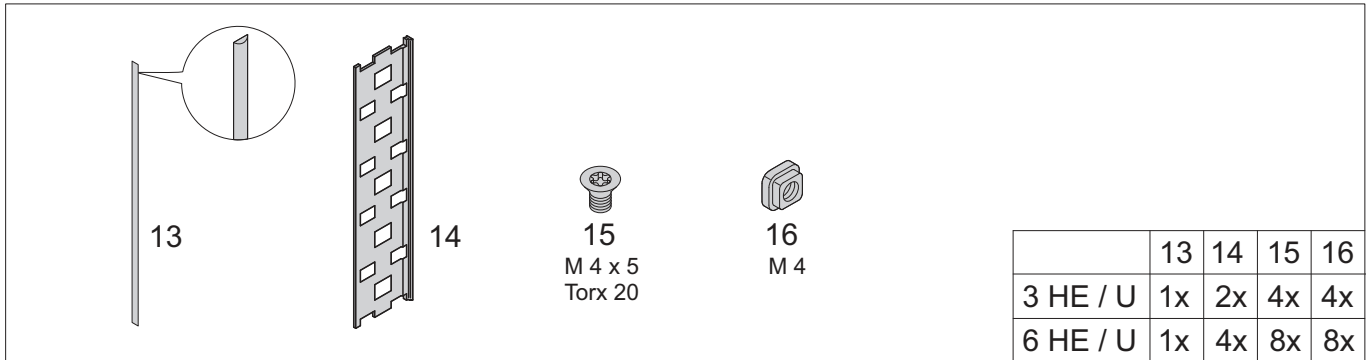

13

14

15
M 4 x 5
Torx 20

16
M 4

	13	14	15	16
3 HE / U	1x	2x	4x	4x
6 HE / U	1x	4x	8x	8x

4

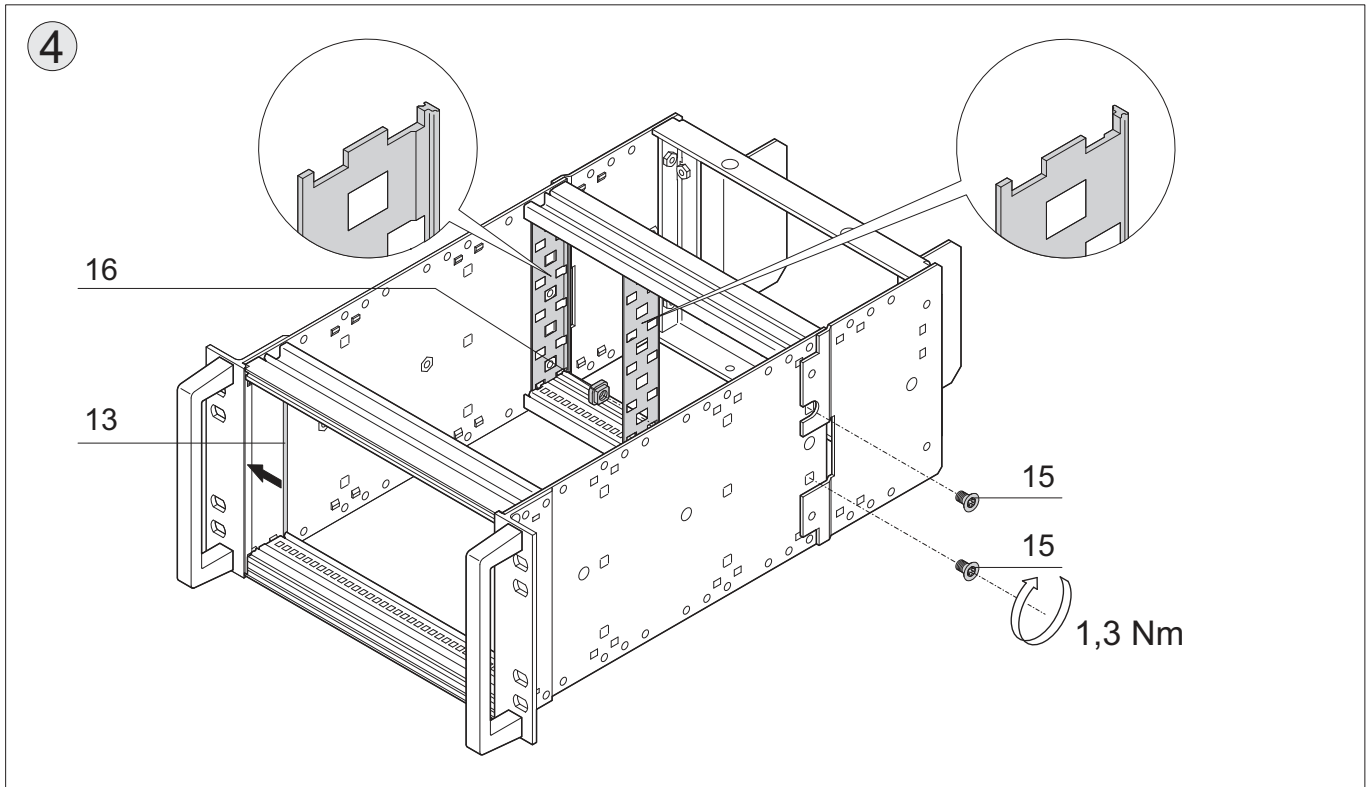

16

13

15

15

1,3 Nm

5

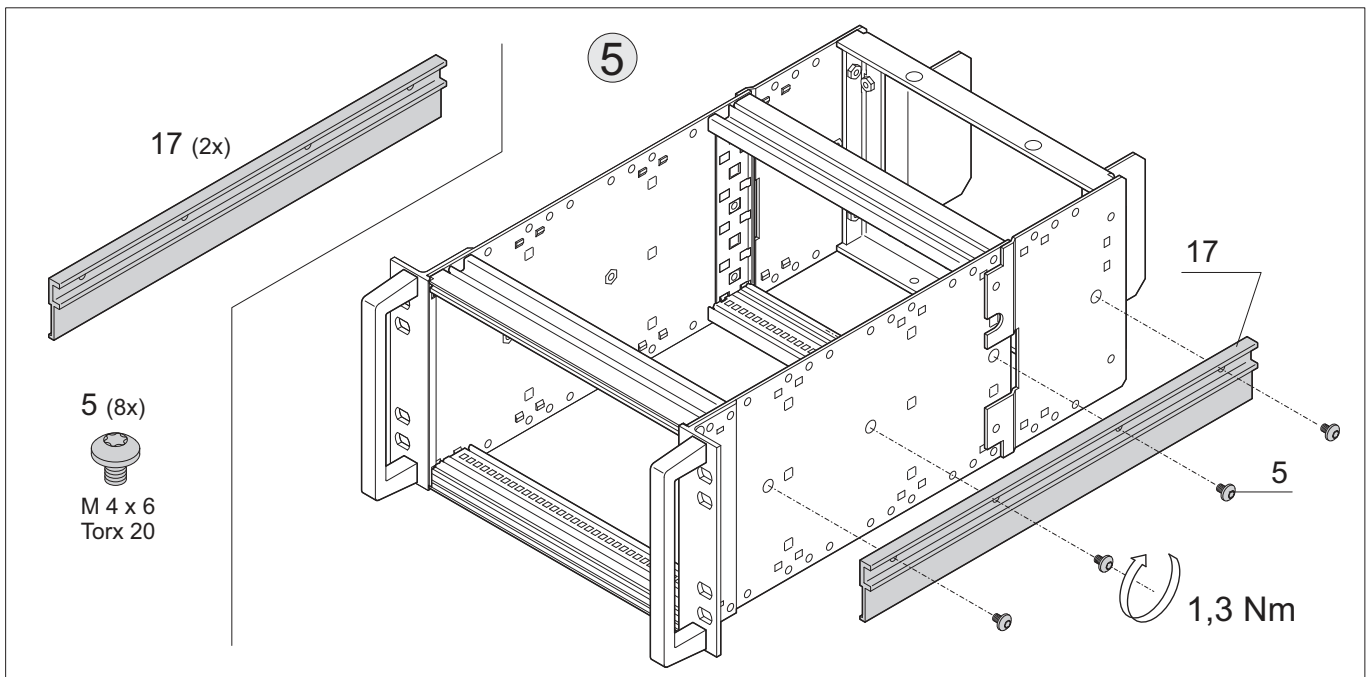

17 (2x)

5 (8x)
M 4 x 6
Torx 20

17

5

1,3 Nm

