

# Installation and Operating Instructions

## Free-standing base

Type



Free-standing base for connecting load-bearing systems

Important: The operating and installation instructions must be read before assembly and usage of the product.  
The instructions must be kept for reference purposes over the product's whole lifetime. /

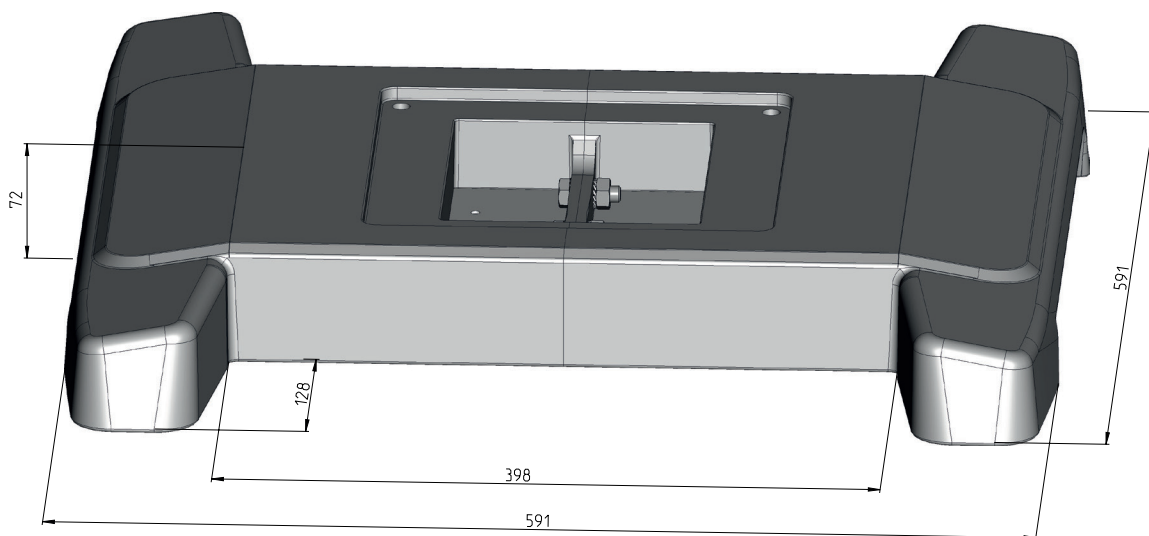

Weight: 11,1 kg

## Directory

Directory	2
Structure and usage of the instructions	2
1. Safety instructions	2
1.1 Intended use	2
1.2 Applicable operating conditions	3
1.3 Installation, operation and maintenance	3
1.4 Protective conductor system	3
1.5 Sealing system	3
1.6 Precautionary measures	4
2. Users / target group / end users	4
3. Compliance with standards	4
4. Mechanical Data	4
5. Static load	5
6. Installation and adjustment	5
6.1 Normal assembly sequence (detailed description on the following pages)	5
7. Installation Earthing system	6
8. Installation adapter plate	8
9. Installation Weight (optional)	9
10. Closure plate	9
11. Cover surfaces for cable entries	10
12. Castors / Mounting adjustable feet	10
13. List of potential errors	11
14. Disposal	11

## Structure and usage of the instructions

The sequence of the chapters is not necessarily the operation or assembly sequence.  
Not all chapters apply for each component.

Use:

- The Flex.Base can be used in various suspension system families by means of appropriate adapter plates.  
The installation is described here as an example for all load-bearing systems.

## 1. Safety instructions

### 1.1 Intended use



Attention

- The stand serves as the ground contacting base of a suspension system or a stand column for mounting or connecting HMI devices. The mounting surface must be flat, even and sufficiently load-bearing (stable).
- The stand can be placed on a flat floor surface. Depending on the application it can be equipped with adjustable feet, firmly mounted to the floor or made mobile by means of castor assembly.
- Maximum loads are shown on page 5.
- Further load-bearing system specifications can be found in the respective valid technical data sheets.
- Incorrect or inadmissible use and non-compliance with the instructions in this manual will void any warranty.

## 1.2 Applicable operating conditions

### - Normal conditions

- Temperature range -5°C to +70°C
- The suspension system may be used only under a rated voltage of max. 400 V AC or 48 V DC for general application in indoor installation.



Attention

### - The following special conditions are not, or only permitted after special consultation:

- Extraordinary mechanical load
- Ionising effects
- Excessive vibration
- Radiation

### - The following conditions must be observed during transportation and storage:

- Storage temperature -10°C to +70°C !

## 1.3 Installation, operation and maintenance

- Improper installation and operation of the Flex.Base leads to the loss of the guaranteed properties and the guarantee.

- For the installation of power line systems, it must be ensured that the power supply is disconnected and suitable protective measures must be taken.

This applies to installation, during operation as well as to repairs and maintenance work.

- Attention: Electric shocks can cause serious health problems, which may lead to death.

- Only original BERNSTEIN parts may be used for replacement and repair.

- Improper and impermissible modifications to the Flex.Base, which are outside the intended use and which do not comply with the specified conditions, can lead to the loss of the warranted properties and the guarantee.

- Appropriate and permissible modifications may only be carried out by experienced and trained electricians and appropriately instructed persons.



Attention

## 1.4 Protective conductor system

- After proper installation and integration into the protective conductor system, the components correspond to protection class I according to EN61140/VDE 0140-1 (protection by protective conductor).

- The supplier or operator of the end product is obliged to install a properly designed protective conductor system. The necessary connection points are prepared accordingly.

- The requirements of VDE 0100 with regard to the earthing of electrical equipment must be observed.

- For the electrical earthing, it must always be ensured that all earthing cross-sections are sufficiently dimensioned with regard to the real conductor cross-section.

- A protective conductor system that has been uninstalled for maintenance and repair purposes must be properly reinstalled before starting operation.



Attention

## 1.5 Sealing system

- Any seals must remain in their intended position during operation.

- Components and seals must not be damaged, otherwise compliance with the tested technical properties is not possible.

- The operating company is responsible for the proper sealing of the product to ensure the appropriate degree of protection. Compliance with the tightening torques is mandatory.



Attention

## 1.6 Protective measures



Attention

- ▶ Possible sharp edges on the underside of the Flex.Base



Attention

- ▶ The excessive crushing, stretching and bending of power lines has to be avoided.



Attention

- ▶ The power line system has to be checked for abrasion points regularly.



Attention

- ▶ Mounting or the electrical connection of the power line system must be carried out by a qualified electrician.



Attention

- ▶ Do not damage seals during installation as otherwise the technical characteristics cannot be complied with.



Attention

- ▶ Care must be taken that any outgoing cables are not stretched or distorted. ATTENTION: Risk of electric shock!



Attention

- ▶ Tightening torque of the screw connections should be inspected on a regular basis.



Attention

- ▶ Objects which are in the moving area of the Flex.Base must be removed to ensure safe movement of the stand and to prevent the stand from tilting.

## 2. Users / target group / end users

- Experienced, trained electricians and appropriately instructed persons
- Experienced, trained fitters and appropriately instructed persons

## 3. Compliance with standards

- Directive 2014/35/EU / February 26, 2014 edition  
(Electrical apparatus for use within certain voltage limits)
- Directive 93/68/EEC / Regulation 768/2008 August 13, 2008 edition (CE Conformity Marking)
- Directive 2002/95/EC or 2011/65/EC (RoHs)

## 4. Mechanical Data

Material:		
Components	GD-Al	Base
	Steel	Adapter plate
Protection class	IP 54	Only in sealed subareas. Sealing must be carried out with accessories!

## 5. Static load

System load

Static load

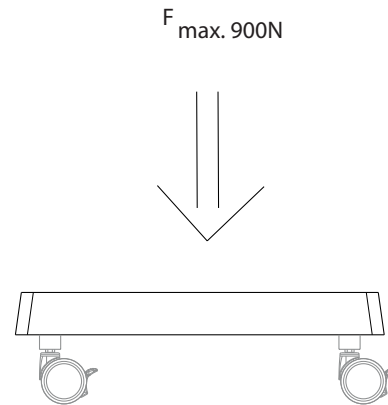

Tilting moment

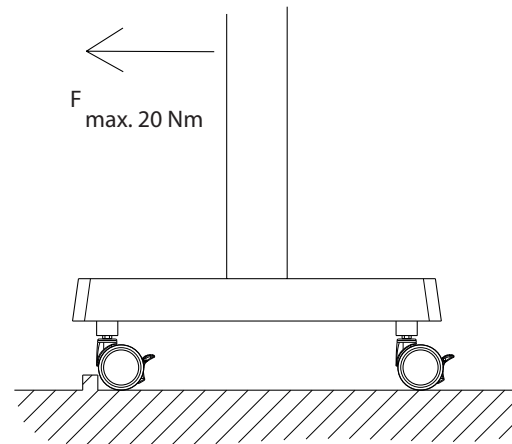

## 6. Installation and adjustment

6.1 Normal assembly sequence (detailed description on the following pages)

1. Screw on the adapter plate
2. Carry out any necessary earthing and wiring measures during component assembly.  
(See chapter Grounding connections).
3. System connection
4. Optionally use weights
5. Screw on the closure plate
6. Mount rollers / feet

## 7. Installation Earthing system

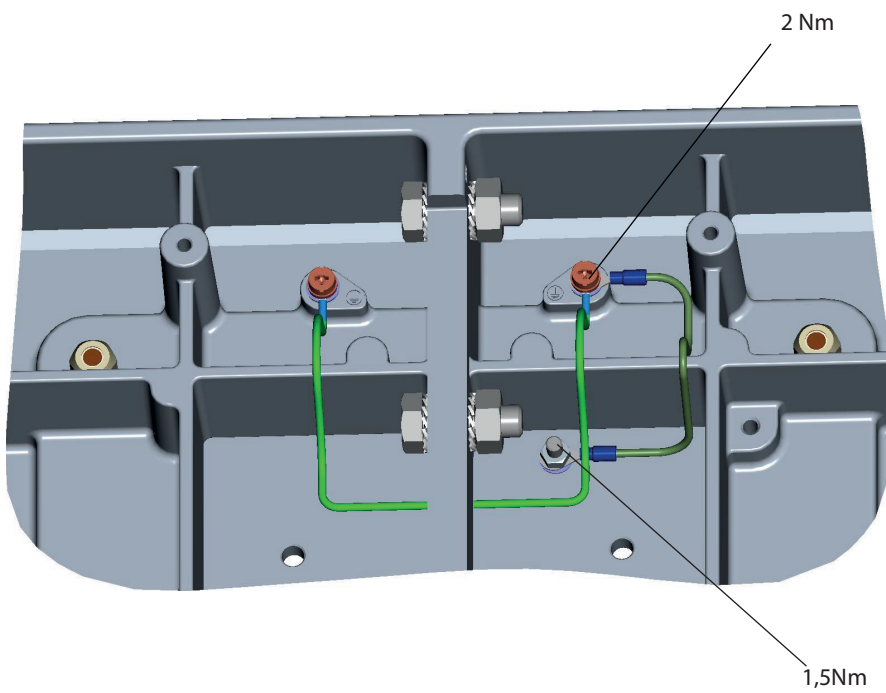
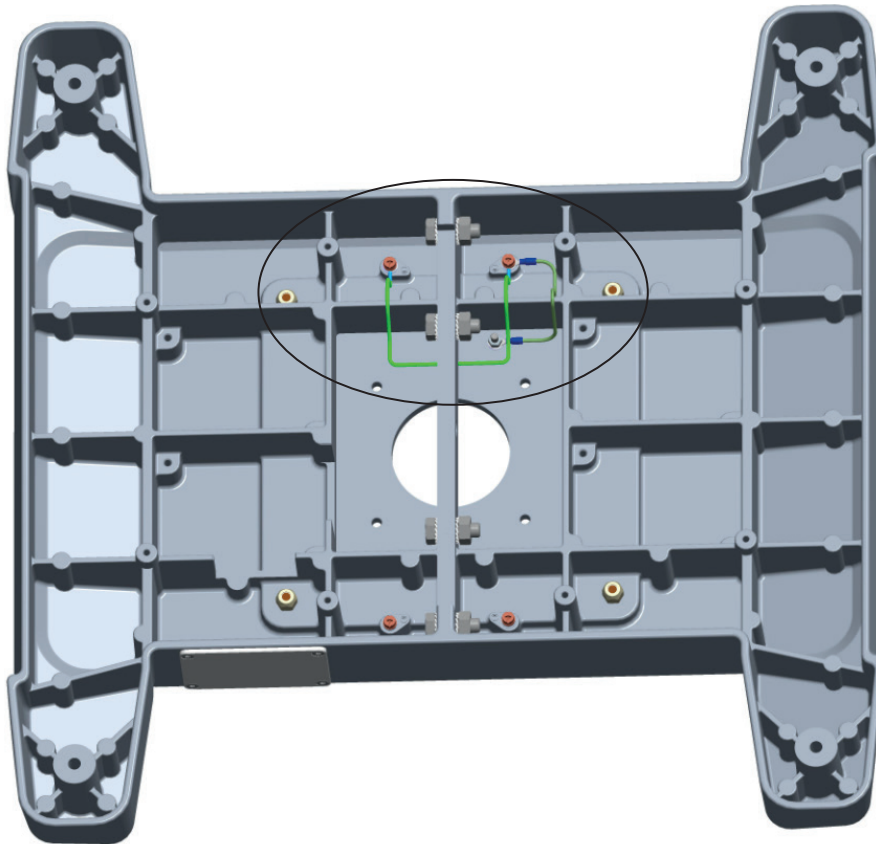

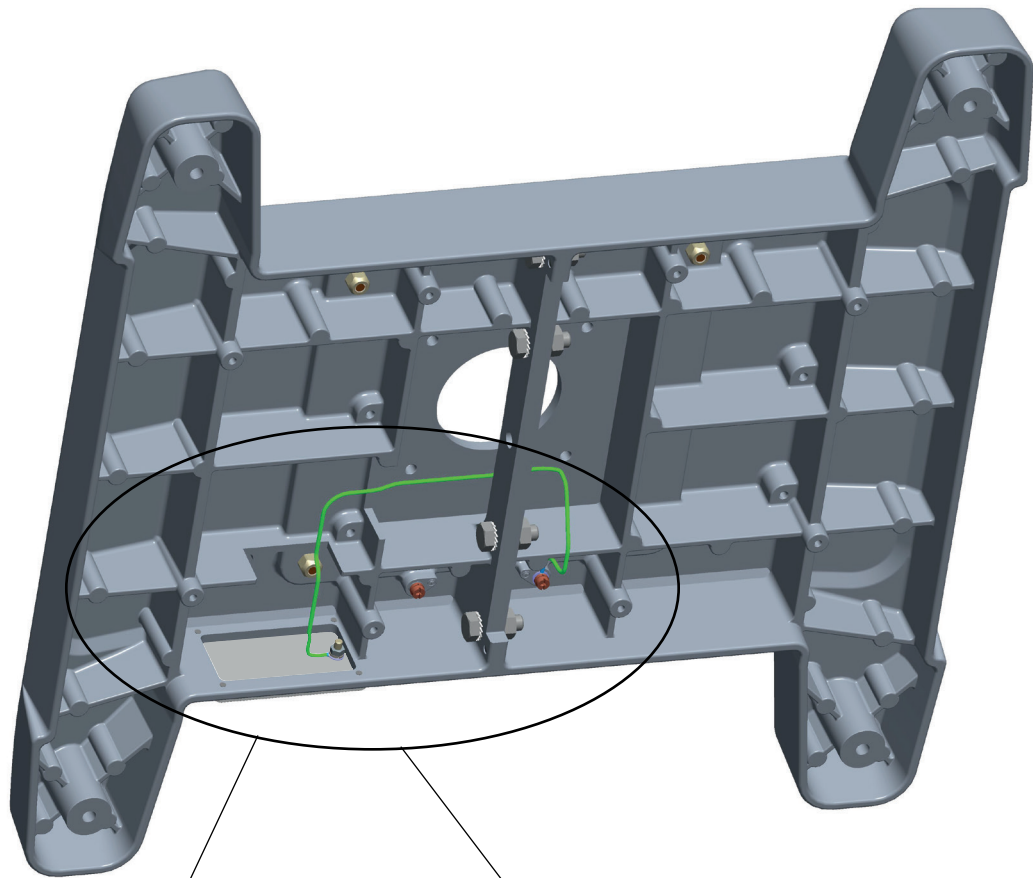

Side for customer connection

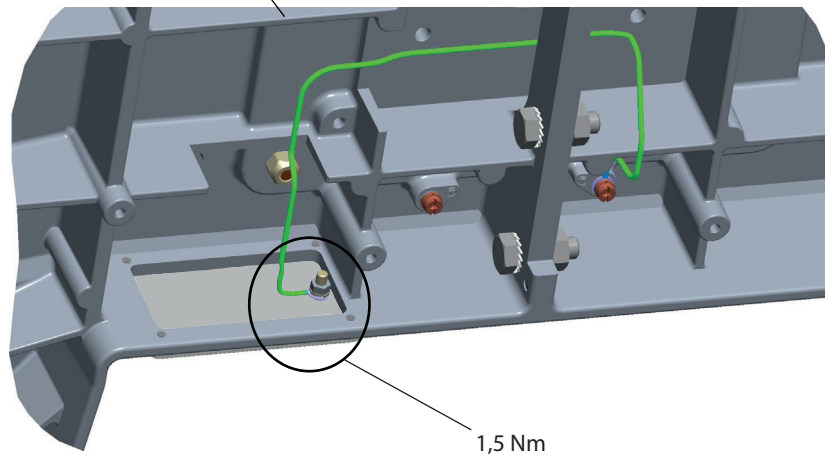

1,5 Nm

Tighten earthing screws M5 to 2 Nm

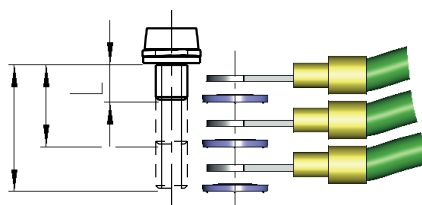

## 8. Installation adapter plate

Weight: ca. 3,6 kg

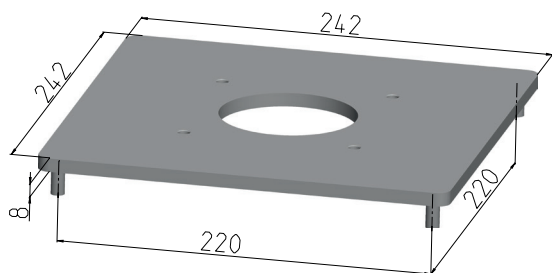

Weight: ca. 5,6 kg

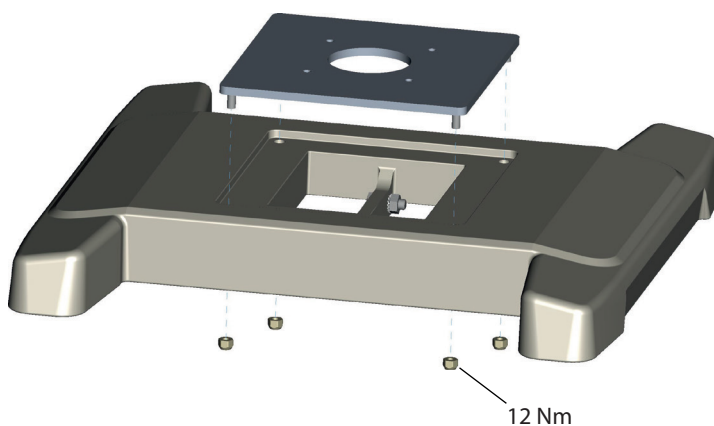
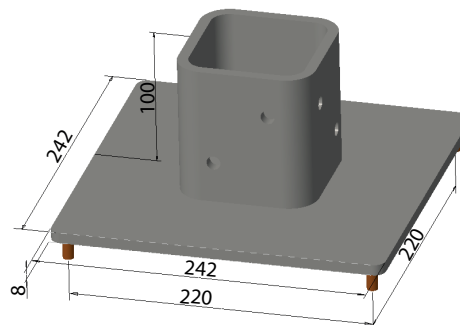

Screw on the adapter plate.

The following example shows the adapter plate S2MSYSAPG.

The same procedure applies to the adapter plates listed in Table 1.

Table 1

Item number	Adapter plate for:	Drilling pattern
S2MSYSAPG	SYSPEND 180-MAX Base SYSPEND 281-MAX Base	100 x 100
S2MCS4APG	CS4 System 80 Mobile base	



## 9. Installation Weight (optional)

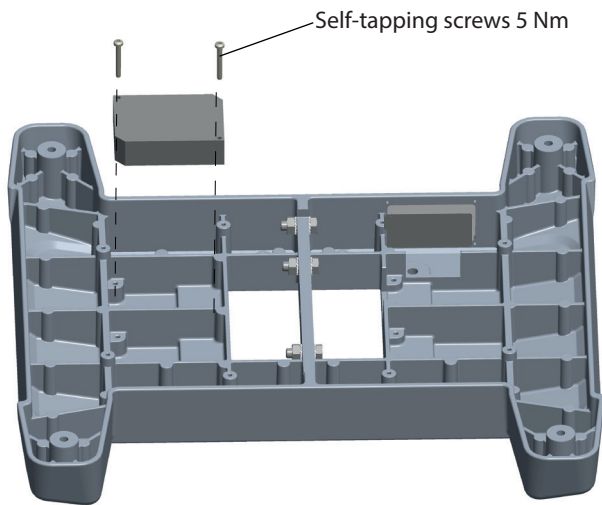

Weight to increase stability

- Screw in weight with 2x M5x40
- Up to 4 weights are possible

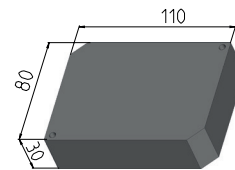

Steel

Weight: 2 kg

## 10. Closure plate

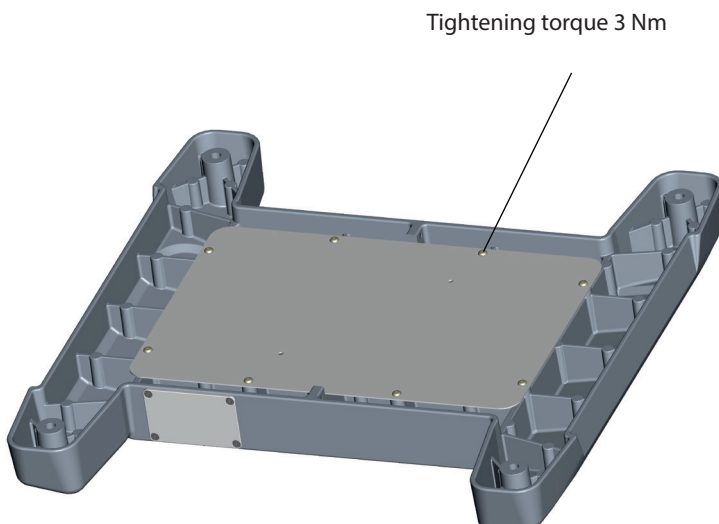

Insert the locking plate  
Fasten plate with 8x M5x10

## 11. Cover surfaces for cable entries

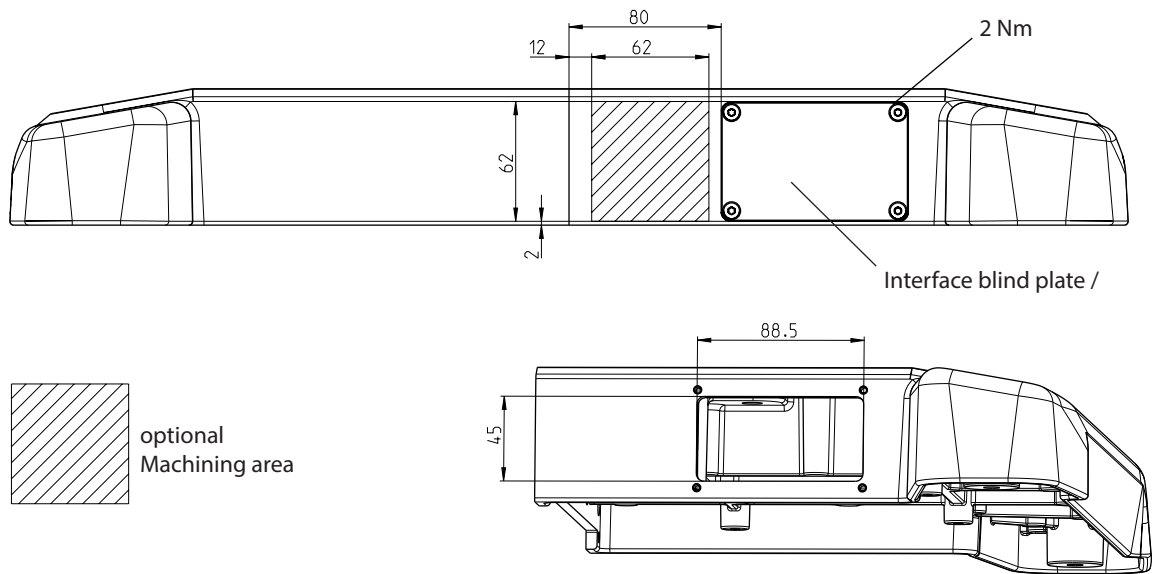

Maximum cover surface determined by opening behind interface blind plate

## 12. Castors / Mounting adjustable feet

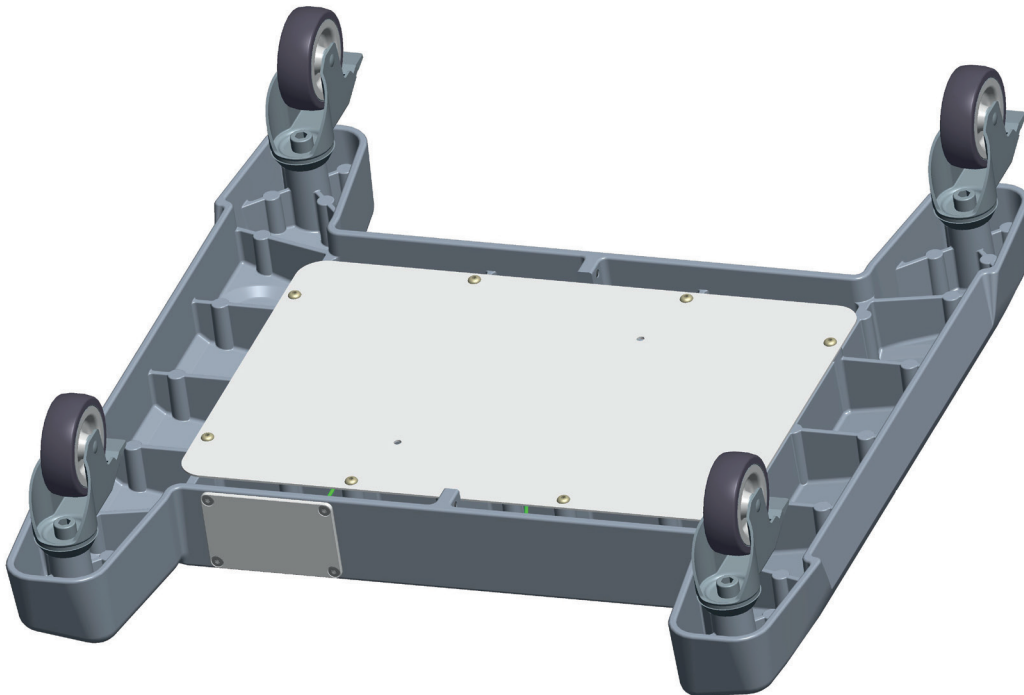

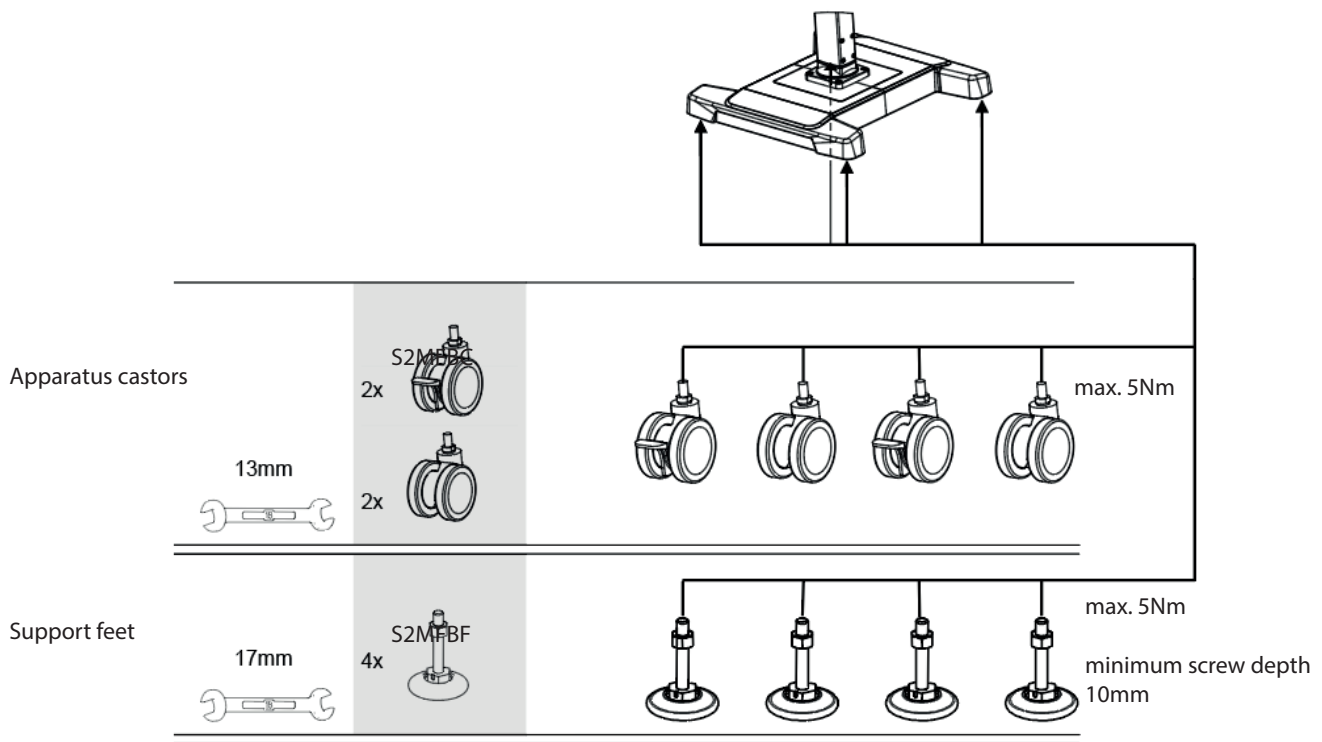

Attention

Attention!

As this is a movable suspension system, this must be observed, that the selected cable lengths allow the movements.



Attention

Attention !

An appropriate strain relief must be provided!

### 13. List of potential errors

Problem	Action	Measure
No fixed connection between the two base halves	Check fastening	Tighten the screws if necessary
No tight fit of the adapter plate	Check fastening	Tighten the screws if necessary
No fixed component connection	Check component fastening	Tighten the screws if necessary
Column profile wobbles	Check fastening	

### 14. Disposal

This product complies with the international directives on the restriction and/or use of certain hazardous substances in electrical and electronic equipment (RoHs). Check with your local waste disposal service to find out how this product can be properly recycled or disposed of.

The German version is the original operating and installation instructions.  
For other languages, the original operating and installation instructions has been translated.

Seite 11 von 11

0800000991\_02/Stand:2/Ausgabedatum:19.07.2023