

ECHD

Ref.	Pic.	Qty.
A		4
B		4
C		4
D		4

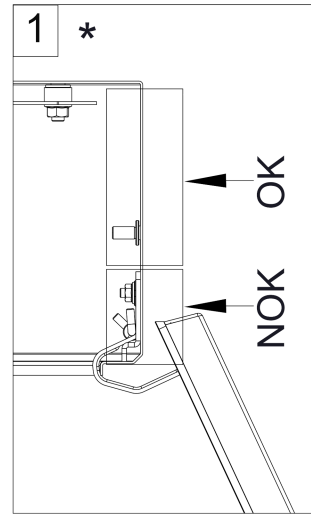

Holes and cut-out

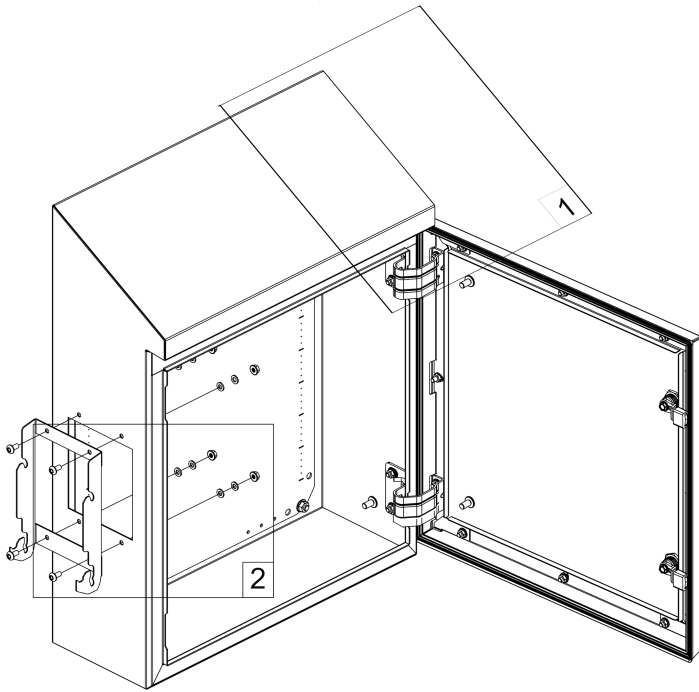
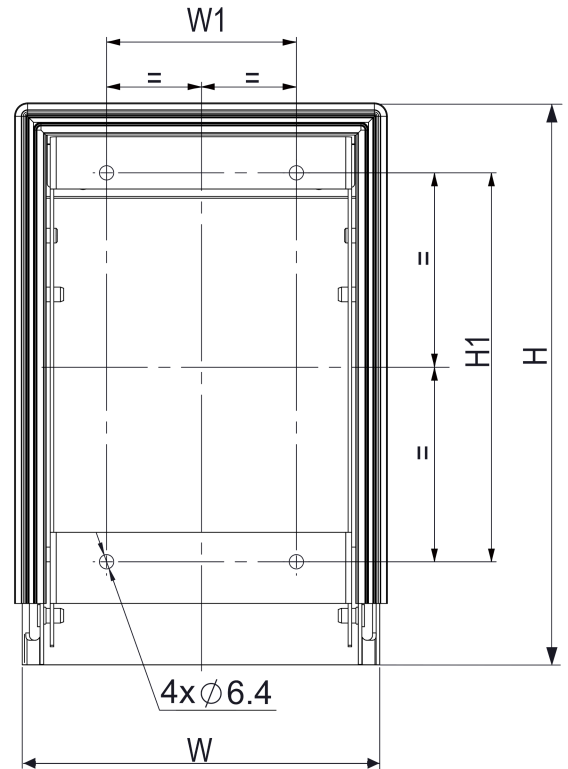
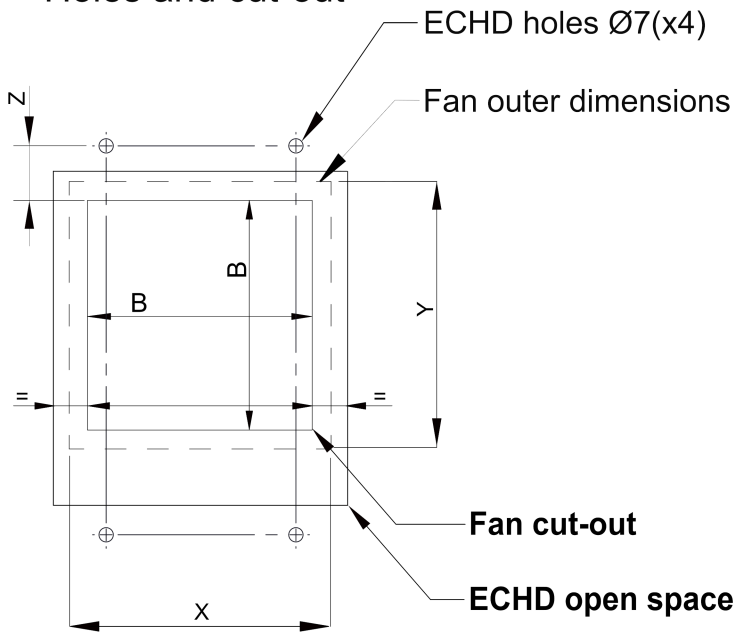

ITEM	H	W	H1	W1	FAN	B(cut-out)	X = Y	Z
ECHD10	230	150	164	80	EF100	92	109	25
ECHD20	260	176	196	112	EF200	125	145	25
ECHD22	330	233	241	168	EF220	177	202	30
ECHD30	390	282	297	218	EF250, EF300	223	252	35
ECHD50	480	350	370	286	EF500	292	320	37
ECHD70					EF600, EF700			

* Door opening and body hinges to be considered for placing ECHD.

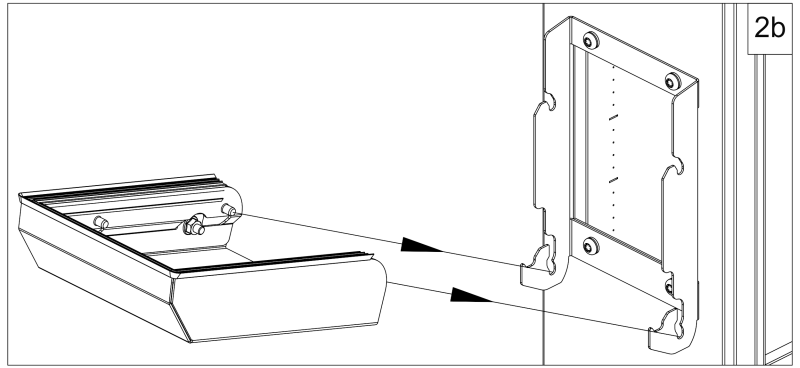
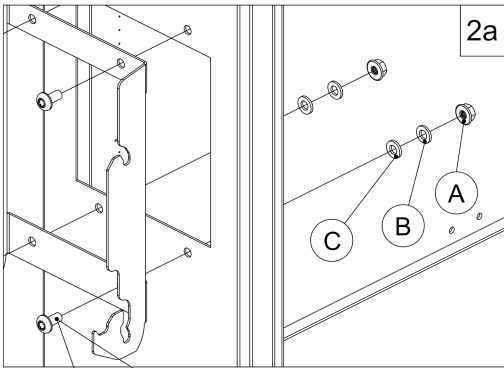

D Torque
5-10 Nm

