

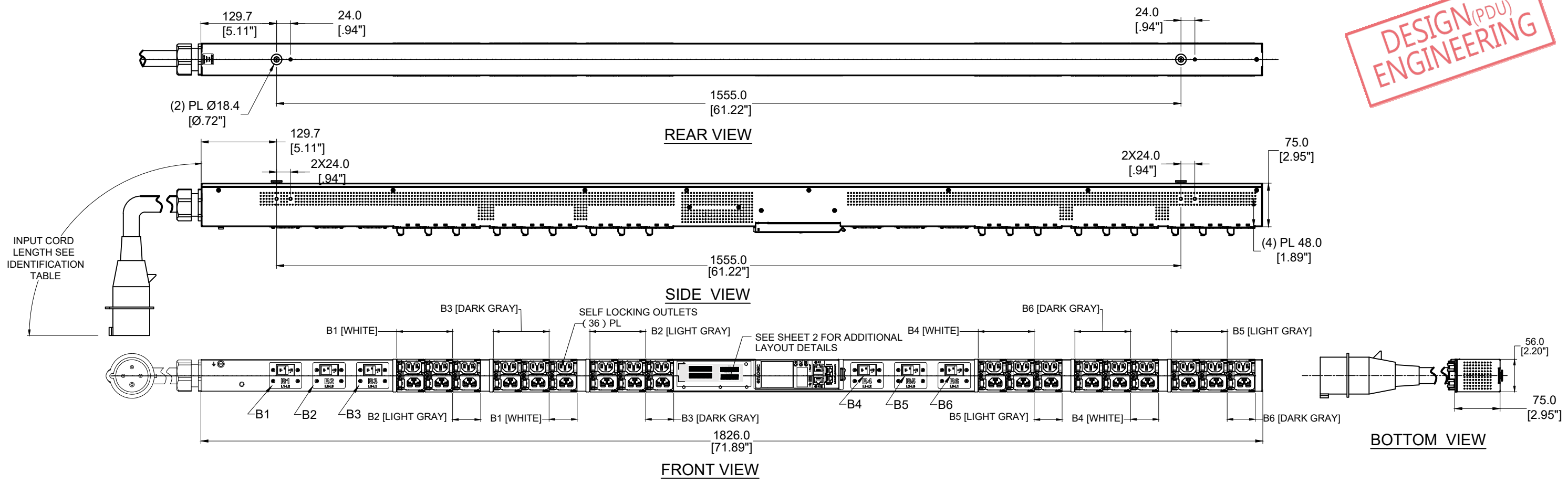

DESIGN (PDU)
ENGINEERING



TECHNICAL SPECIFICATIONS	
UNIT TYPE:	MONITORED & SWITCHED PER OUTLET
ORIENTATION:	VERTICAL, 0U FULL
OUTLET QTY & TYPE:	(18)C13/C15 LOCKING, (18)C13/C15/C19 LOCKING
INPUT VOLTAGE:	208VAC
INPUT CURRENT:	60A (48A DERATED)
BREAKER QTY & TYPE:	(6) 20AMP, DOUBLE-POLE, 5KAIC
INPUT PHASE:	THREE-PHASE, DELTA
RATED POWER:	17.3 KVA
INPUT PLUG:	SEE NOTE 7
INPUT POWER CORD:	SEE IDENTIFICATION TABLE
FEATURES	
METERING ACCURACY	+/-1% TO ISO/ IEC 62052-21
METERING ATTRIBUTES	VOLTAGE(V), CURRENT(A), APPARENT POWER(kVA), REAL POWER(kW), POWER FACTOR, ENERGY(kWh)
METERED COMPONENTS	INPUT(PHASE),CIRCUIT BREAKERS,OUTLETS
REMOTE OUTLET SWITCHING	YES
ENVIRONMENTAL CONDITIONS	
OPERATING TEMPERATURE	-5 TO 60 C (23 TO 140 F)
STORAGE TEMPERATURE	-20 TO 60 C (-4 TO 140 F)
HUMIDITY (OPERATING/STORAGE)	5-90% RH / 5-95% RH; NON-CONDENSING
MAX OPERATING ELEVATION, ABOVE MSL	3000M(9840FT)
COMPLIANCE	
SAFETY&ENVIRONMENTAL	RoHS COMPLIANT

IDENTIFICATION TABLE	EN6982-*	* INPUT PLUG	* CHASSIS COLOR	* CORD OPTION	* ORIENTATION
MODEL IS SHOWN IN DEFAULT CONFIGURATION. FOR OPTIONAL CONFIGURATIONS, USE ITEM IDENTIFIER CODE IN PLACE OF EACH ASTERISK. ORDERABLE BASED ON FORMAT: EN 6982-****		(DEFAULT) 460P9 (IP44) =0 460P9W (IP67) =Z	(DEFAULT) BLACK = 0 BLUE = B RED = R GREEN = G WHITE = W YELLOW = Y	(DEFAULT) 1.8m [6'] = 0 1m [3.2'] = 1 2m [6.6'] = 2 3m [10'] = 3	(DEFAULT) TOP FEED = 0 BOTTOM FEED = 2
OPTIONS LISTED ON THIS ROW ARE NON STANDARD, CONTACT SALES FOR ADDITIONAL INFORMATION			ORANGE = A	0.5m [1.6'] = A 1.2m [4'] = G 1.5m [4.9'] = B 1.8m [6'] = F 2.5m [8.2'] = C	

- NOTES :**
- INSTALLATION SHALL COMPLY WITH ALL APPLICABLE NATIONAL, STATE AND LOCAL CODES.
 - PRIMARY DIMENSIONS ARE IN MILLIMETERS. SECONDARY DIMENSIONS ARE IN [INCHES]
 - UNIVERSAL MOUNTING BRACKET IS AN ALTERNATIVE MOUNTING METHOD TO THE TOOLLESS MOUNT FOR 3RD PARTY ENCLOSURES. BRACKET IS PROVIDED WITH THE UNIT.
 - DETAILED INSTALLATION INSTRUCTIONS CAN BE FOUND IN THE QUICK START GUIDE
 - CONNECT EXTERNAL EARTH GROUND TO THE 10-32 SIZE THREADED NUT
 - SEE PRODUCT DOCUMENTATION FOR FURTHER INFORMATION
 - INPUT PLUG CONFIGURATION (SEE IDENTIFICATION TABLE) FOR DUAL-RATED UNITS, NEMA PLUGS ARE NAM RATED ONLY AND CAPTIVE AUS/NZ PLUGS ARE EMEA RATED ONLY



THIS DRAWING AND SPECIFICATIONS HEREIN ARE THE PROPERTY OF CIS GLOBAL AND SHALL NOT BE COPIED, REPRODUCED OR USED IN WHOLE OR IN PART, AS THE BASIS FOR THE MANUFACTURE OR SALE OF ITEMS WITHOUT WRITTEN PERMISSION FROM CIS GLOBAL. THIS DRAWING IS BASED UPON LATEST AVAILABLE INFORMATION AND IS SUBJECT TO CHANGE WITHOUT NOTICE

ECN/ECO	REV.	DESCRIPTION	DATE	APPROVED
	E1	INITIAL DRAFT REVIEW	2022/07/28	Leo Liu
REVISIONS				
TITLE :		UNLESS NOTED, DIMENSIONS ARE IN MILLIMETERS & TOLERANCES ARE:		
Advantage Series Metered & Switched per outlet		X ±1 MM	X° ±1°	PART NO: EN6982-WXYZ_DA
		XX ±0.5 MM	XX° ±0.5°	
PROJECT : enLOGIC		X ±0.20 MM		DRAWN BY: Leo Liu
		Ø X.X ±0.3 MM		2022/07/28
		Ø X.XX ±0.10 MM		ENGINEER: Luo Jingbo
				2022/07/28
		BRACKETED DIMENSIONS ARE IN INCHES FOR REFERENCE ONLY		APPROVED BY: Hanson
		THIRD ANGLE PROJECTION		2022/07/28
		INTERPRET PER ASME Y14.5M-1994		
			SCALE : N/A	SHEET 1 OF 3
				SIZE: A3

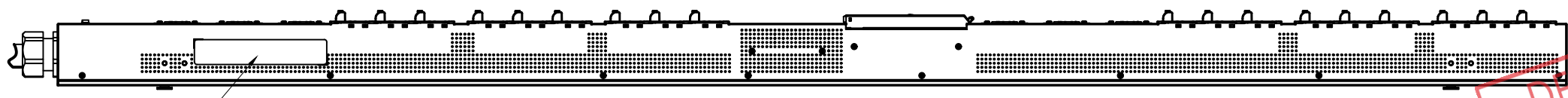

PRODUCT LABEL

SIDE VIEW

DESIGN (PDU)
ENGINEERING

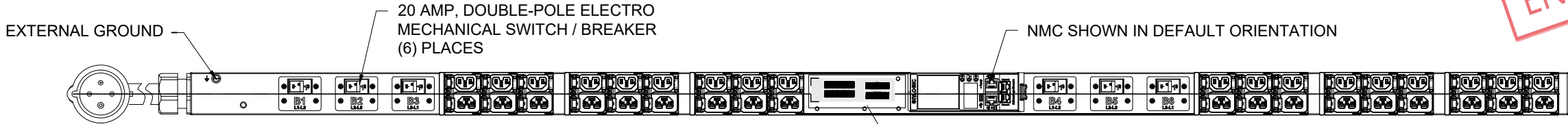

EXTERNAL GROUND

20 AMP, DOUBLE-POLE ELECTRO MECHANICAL SWITCH / BREAKER (6) PLACES

NMC SHOWN IN DEFAULT ORIENTATION

LABEL DETAIL



FRONT VIEW

FULLY DEPRESS RELEASE BUTTON PRIOR TO INSTALLING PLUG FOR EASIEST INSTALL

(PLUG CAN ALSO BE INSERTED WITHOUT DEPRESSING RELEASE BUTTON)

TO UNLOCK, FULLY DEPRESS RELEASE BUTTON AND REMOVE PLUG

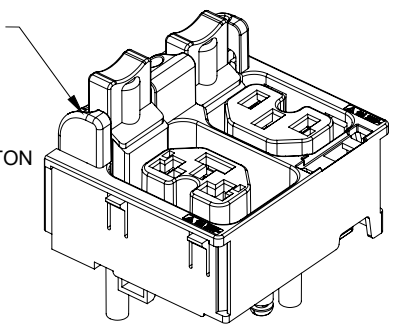

LOCKING COMBO OUTLET

STANDARD RECEPTACLES

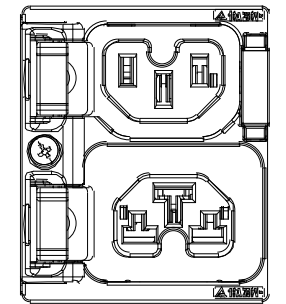

RECEPTACLE

IEC 60320 C13, C15
MAX RATED OUTPUT 10A, 250V

IEC 60320 C13, C15, C19, C21
MAX RATED OUTPUT 16A, 250V

INPUT PLUG

(DEFAULT)



IEC 60309, 3P 4W, 9H
IP44 (SPLASHPROOF)
60A, 250V, 3-PHASE MAX
RATED INPUT 48A DERATED

OPTIONAL



IEC 60309, 3P 4W, 9H
IP67 (WATERTIGHT)
60A, 250V, 3-PHASE MAX
RATED INPUT 48A DERATED

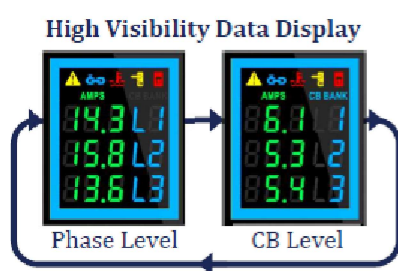

Phase Level

CB Level



Critical Alarm Alerts

- ⚠ PDU Alarm
- 🔗 Cascade Error
- 🌡 Environmental Alarm
- 🔒 Security Alarm
- 🔥 Circuit Breaker Alarm

Source Color Coding (User Selected Option)



User Interactive Display (for setup and detailed information)

10/100 Ethernet Port (for redundancy and Ethernet cascading)
Digital Sensor Port 2

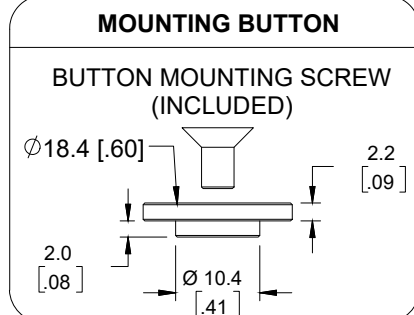

USB-C (upgrades, connectivity, and future-proof expansion)

10/100/Gigabit Ethernet Port (primary network port)

Digital Sensor Port 1 (supports up to 8 physical sensors)

E1	INITIAL DRAFT REVIEW	2022/07/28	Leo Liu
ECN/ECO	REV.	DESCRIPTION	DATE APPROVED

REVISIONS

TITLE : Advantage Series Metered & Switched per outlet		UNLESS NOTED, DIMENSIONS ARE IN MILLIMETERS & TOLERANCES ARE: X ±1 MM X° ±1° X.X ±0.5 MM X.X° ±0.5° X ±0.20 MM Ø X.X ±0.3 MM Ø X.XX ±0.10 MM		PART NO: EN6982-WXYZ_DA		REV. E1	
PROJECT : enLOGIC		BRACKETED DIMENSIONS ARE IN INCHES FOR REFERENCE ONLY ⊕ THRID ANGLE PROJECTION INTERPRET PER ASME Y14.5M-1994		DRAWN BY: Leo Liu		2022/07/28	
				ENGINEER: Luo Jingbo		2022/07/28	
				APPROVED BY: Hanson		2022/07/28	
				SCALE : N/A		SHEET 2 OF 3	
						SIZE: A3	

- NOTES :
- INSTALLATION SHALL COMPLY WITH ALL APPLICABLE NATIONAL, STATE AND LOCAL CODES.
 - SEE PRODUCT DOCUMENTATION FOR FURTHER INFORMATION

enLOGIC by nVent

THIS DRAWING AND SPECIFICATIONS HEREIN ARE THE PROPERTY OF CIS GLOBAL AND SHALL NOT BE COPIED, REPRODUCED OR USED IN WHOLE OR IN PART, AS THE BASIS FOR THE MANUFACTURE OR SALE OF ITEMS WITHOUT WRITTEN PERMISSION FROM CIS GLOBAL. THIS DRAWING IS BASED UPON LATEST AVAILABLE INFORMATION AND IS SUBJECT TO CHANGE WITHOUT NOTICE

enLOGIC RACK Power Distribution Unit Made In XXXXX

Metered & Switched per outlet

SKU#: EN6982-WXYZ

Model #: EP164048-0065-L

INPUT: 200-240VAC, DELTA, 3PHASE, 50/60Hz, 48A

OUTPUT: C13/C15 LOCKING; 200-240VAC, 10A per outlet
C13/C15/C19 LOCKING; 200-240VAC, 16A max per outlet
48A Total

MAC0 Address:XX-XX-XX-XX-XX-XX
MAC1 Address:XX-XX-XX-XX-XX-XX

FC C SP 300805

Serial Number
XXXXXX X X X X

THIS DEVICE COMPLIES WITH PART 15 OF THE FCC RULES. OPERATION IS SUBJECT TO THE FOLLOWING TWO CONDITIONS:
(1) THIS DEVICE MAY NOT CAUSE HARMFUL INTERFERENCE, AND (2) THIS DEVICE MUST ACCEPT ANY INTERFERENCE RECEIVED, INCLUDING INTERFERENCE THAT MAY CAUSE UNDESIRABLE OPERATION, CAN ICES-3(A)/NMB-3(A)

COMPLIANCE LABEL

NOTES:

1. INTERNAL WIRING

WIRE TYPE: UL AWM 1015,10 & 12 & 18 AWG

LINE 1/R/X COLOR: Black

LINE 2/S/Y COLOR: Orange

LINE 3/T/Z COLOR: Red

EARTH GROUND COLOR: Green/Yellow

2. FOR FINISHED GOOD PART NUMBER SEE IDENTIFICATION

DESIGN(PDU)
ENGINEERING

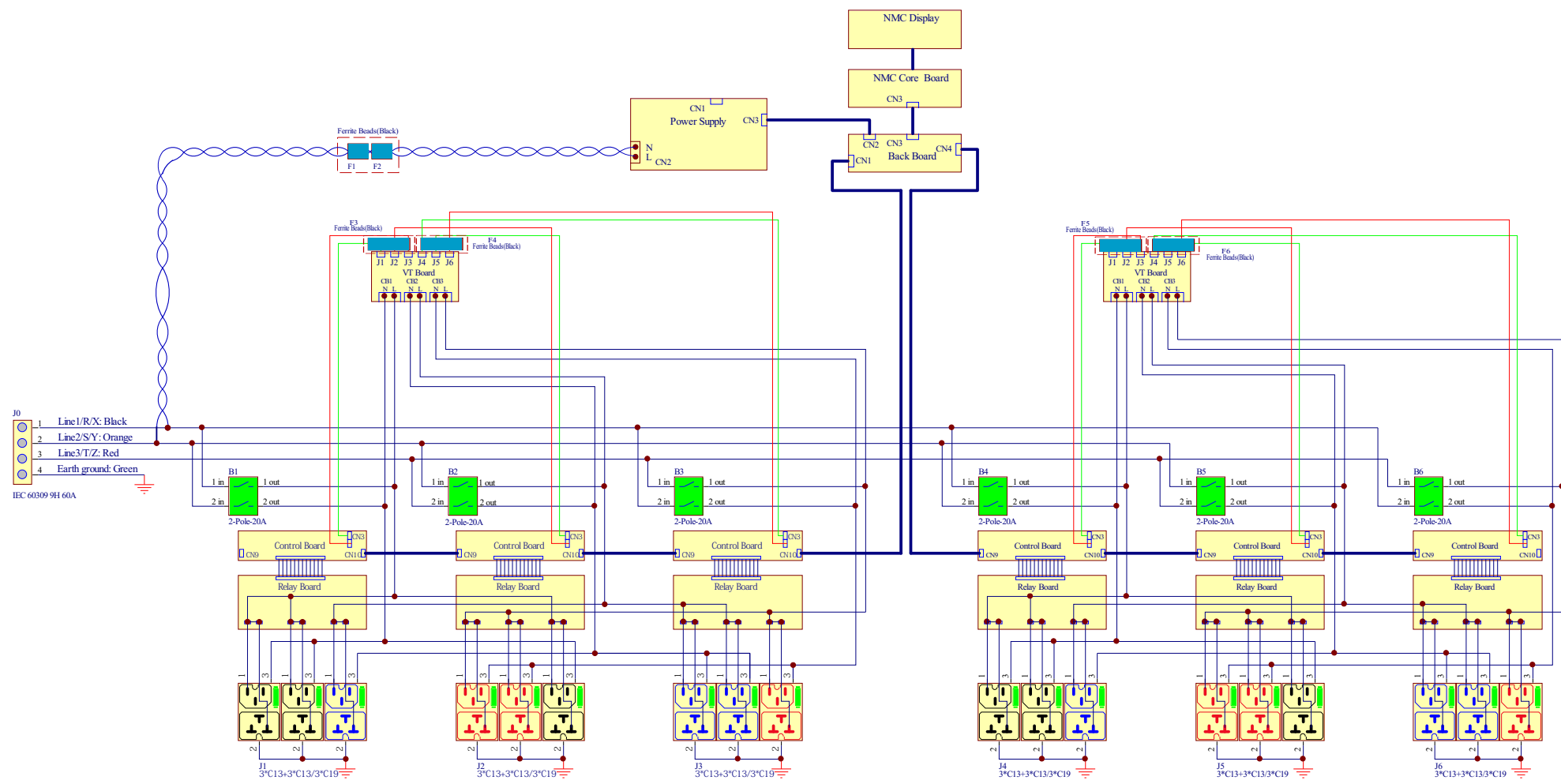

INTERNAL WIRING SCHEMATIC DIAGRAM

- NOTES:
1. INSTALLATION SHALL COMPLY WITH ALL APPLICABLE NATIONAL, STATE AND LOCAL CODES.
 2. SEE PRODUCT DOCUMENTATION FOR FURTHER INFORMATION.
 3. THIS DRAWING DEPICTS THE POWER SYSTEM CONNECTIONS AND IS NOT REPRESENTATIVE OF THE PHYSICAL LAYOUT. PLEASE REFER TO MECHANICAL DRAWINGS FOR PHYSICAL LAYOUT.

enLOGIC by nVent

THIS DRAWING AND SPECIFICATIONS HEREIN ARE THE PROPERTY OF CIS GLOBAL AND SHALL NOT BE COPIED, REPRODUCED OR USED IN WHOLE OR IN PART, AS THE BASIS FOR THE MANUFACTURE OR SALE OF ITEMS WITHOUT WRITTEN PERMISSION FROM CIS GLOBAL. THIS DRAWING IS BASED UPON LATEST AVAILABLE INFORMATION AND IS SUBJECT TO CHANGE WITHOUT NOTICE

	E1	INITIAL DRAFT REVIEW	2022/07/28	Leo Liu
ECN/ECO	REV.	DESCRIPTION	DATE	APPROVED
REVISIONS				
TITLE :		UNLESS NOTED, DIMENSIONS ARE IN MILLIMETERS & TOLERANCES ARE:	PART NO:	REV.
Advantage Series Metered & Switched per outlet		X ±1 MM	EN6982-WXYZ_DA	E1
		X.X ±0.5 MM	DRAWN BY: Leo Liu	2022/07/28
PROJECT : enLOGIC		X ±0.20 MM	ENGINEER: Luo Jingbo	2022/07/28
		Ø X.X ±0.3 MM	APPROVED BY: Hanson	2022/07/28
		Ø X.XX ±0.10 MM	SCALE : N/A	SHEET 3 OF 3
		BRACKETED DIMENSIONS ARE IN INCHES FOR REFERENCE ONLY		SIZE: A3
		THIRD ANGLE PROJECTION		
		INTERPRET PER ASME Y14.5M-1994		