



## Important Safety Instructions

Read all instructions & safety warnings prior to installation



## NOTE: SAVE THESE INSTRUCTIONS

This manual contains important instructions that shall be followed during installation and maintenance of the Soltection RJ-1 rooftop junction box with flashing.



Lethal voltages are present during the installation, operation and service of this equipment. Proper precautions must be taken at all times to ensure the safety of the service personnel.

## WARNING:

### Safety Warnings & Cautions

- Only qualified personnel or licensed electricians should install this product and the instructions herein are provided for those individual(s) only.
- To reduce the risk of electric shock, injury, or death, all electrical wiring and connections must be performed by qualified personnel.
- Lethal voltages are present during the installation, operation, and servicing of this equipment. Proper precautions must be taken at all times to ensure the safety of the service personnel.
- Follow state and federal Occupational Safety and Health Administration (OSHA) guidelines and regulations when installing this product.
- Utilize proper Personal Protective Equipment (PPE) as required per national and local regulations as well as for installation best practices.
- Install this apparatus in accordance with ANSI/NFPA 70, National Electrical Code (NEC). Follow all national or local electrical codes.
- Install, operate, and use this product in a manner consistent with the instructions provided. Failure to follow the procedures indicated may result in roof leaks, property damage, or consequential damage.

### Electrical Precautions

- Ensure all electrical conductors are at zero voltage potential before installing or servicing this unit.
- Never break contact on a circuit without using the appropriate disconnect device.
- Follow established lockout and tagout procedures for all electrical conductors prior to servicing.
- Beware of power lines in the vicinity of the roof, where inadvertent contact may result in electrocution, personal injury or death.
- When disconnecting source or supply circuits, provide sufficient time as stated in the power electronics manufacturer's instruction manual in order to ensure discharge of all conductors in the circuit.
- Always verify the integrity and proper installation of the electrical components prior to energizing electrical circuits.
- Non-metallic enclosures do not provide grounding means between conduit connections. The use of grounding hubs and jumper wires are required.
- Grounding must be sized per NEC requirements, and is the responsibility of the installer.

### Mechanical Precautions

- When drilling into an attic space, ensure that electrical wires, mechanical obstructions, or
- potential electrical hazards are removed from the vicinity and direction of the drill.
- Do not install if the roof is wet, frosted, or covered by ice or snow.
- If any part of this product becomes damaged, remove and destroy the entirety of the unit.
- Failure to do so may result in fire, property damage, personal injury, electrocution, or death.
- Do not use the product to anchor fall protection equipment.

**WARRANTIES:** Seller warrants to Buyer that products and any services furnished hereunder will be free from defects in material, workmanship and title and will be of the kind and quality specified in Seller's written quotation. The foregoing shall apply only to failures to meet said warranties (excluding any defects in title) which appear within two years from the date of shipment hereunder.

The conditions of any tests shall be mutually agreed upon and Seller shall be notified of, and may be represented at, all tests that may be made. The warranties and remedies set forth herein are conditioned upon (a) proper storage, installation, use and maintenance, and conformance with any applicable recommendations of Seller and (b) Buyer promptly notifying Seller of any defects and, if required, promptly making the product available for correction.

If any product of service fails to meet the foregoing warranties (except title), Seller shall thereupon correct any such failure either at its option, (i) by repairing any defective or damaged part or parts of the products, or (ii) by making available, F.O.B. Seller's plant or other point of shipment, any necessary repaired or replacement parts. Where a failure cannot be corrected by Seller's reasonable efforts, the parties will negotiate an equitable adjustment in price.

The preceding paragraph sets forth the exclusive remedies for claims (except as to title) based on defect in or failure of products or services; whether the claim is in contract, indemnity, warranty, tort (including Seller's negligence), strict liability or otherwise and however instituted. Upon the expiration of the warranty period, all such liability shall terminate and Buyer shall have a reasonable time, within thirty days after the warranty period, to give written notice of any defects which appeared during the warranty period. Except as set forth in Article 2, "Patents," the foregoing warranties are exclusive and in lieu of all other warranties, whether written, oral, implied or statutory. NO IMPLIED STATUTORY WARRANTY OF MERCHANTABILITY OR FITNESS FOR PARTICULAR PURPOSE SHALL APPLY. Seller does not warrant any products or services of others which Buyer has designated.

1

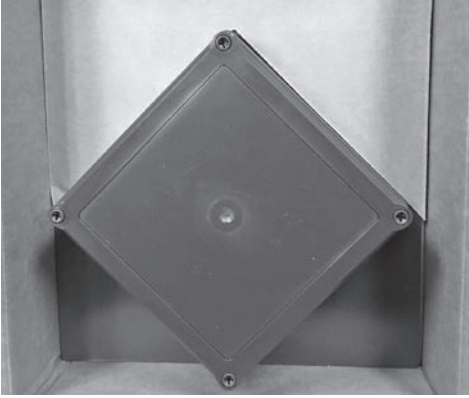

Position the top point of the cover 1" above the bottom of the 1st course of shingle as shown.

2

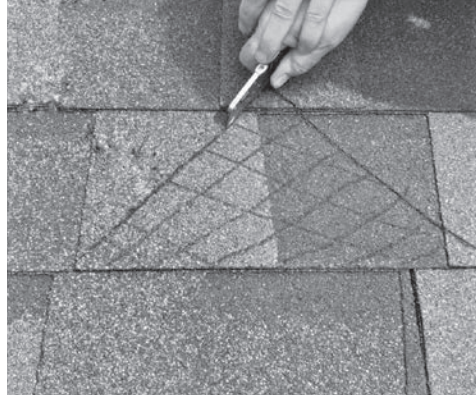

Trace and continue using a lumber crayon to the bottom of the 2nd course. Cut along lines and remove shingles.

3



Remove any roofing nails beneath the 1st, 2nd, or 3rd course of tile that obstructs the position of the roof flashing.

4

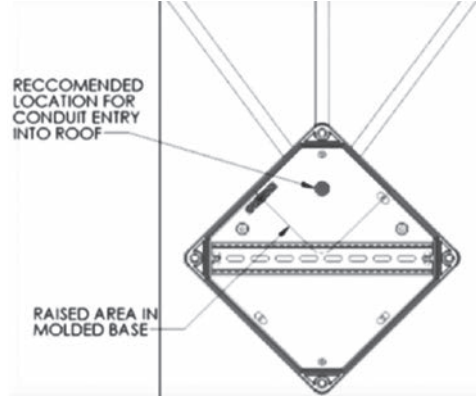

Slide RJ-1 junction box into place where you cut shingle template. The image above shows where you will drill in the next step.

5



**Drill Pilot Hole**  
Slide RJ-1 junction box into location where you cut shingle template. Using 1/4" drill bit drill through box and roof simultaneously (for location see step 4).

6

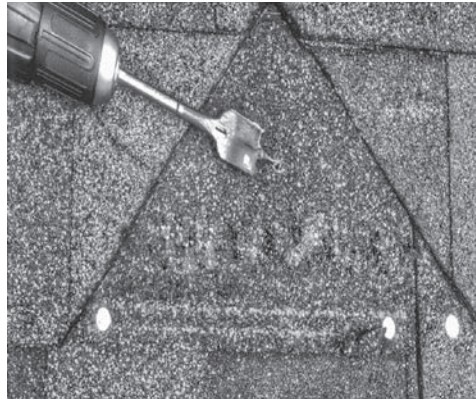

Remove box and see pilot hole in roof.

7

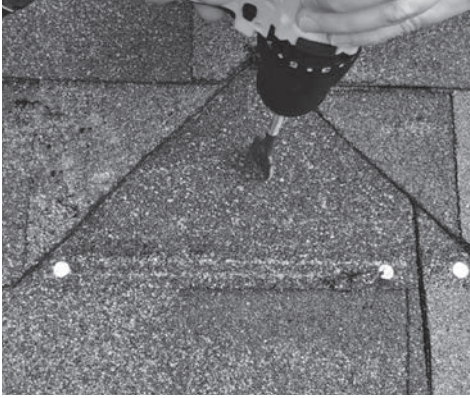

Using the pilot hole, drill through the roof the diameter necessary to ensure that it will accommodate the appropriate conduit fitting.

8

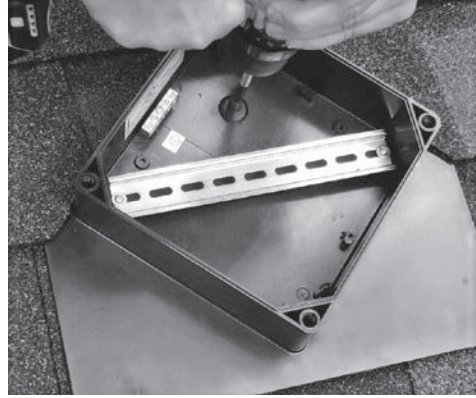

Reinstall box and using the pilot hole again, drill the diameter necessary to ensure that it will accommodate the appropriate conduit fitting.

9

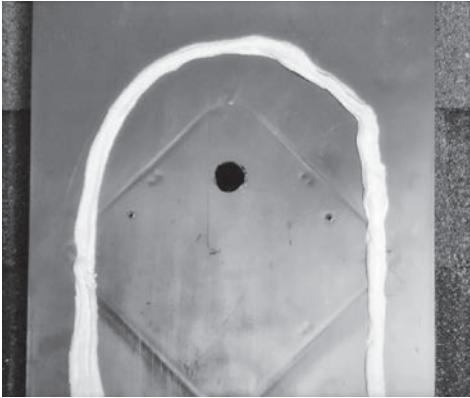

Remove RJ-1, flip it over, wipe it clean and apply a bead of roofing sealant to the underside of the flashing unit. Ensure that it's placed in the "Upside-down U" shape to support ingress water protection, AS SHOWN.

10



Reinstall Unit. Use the two supplied decking screws to mount the flashing to the roof. Torque to the specification indicated in the specifications. Refer to **Table T2 (page 5)** for the proper tightening torques.

10 A

**POPULATE RJ-1**

- Populate the RJ-1 unit using the appropriate wire connectors, terminal blocks or other necessary components.
- Ensure that the components installed are rated for and are suitable for the intended purpose.
- The RJ-1 unit is provided with multiple standoffs which can accommodate accessories to be mounted.

11



Install the cover onto the top of the enclosure. Tighten four cover screws to the Torque value indicated in **Table T3 (see page 5)**.

## SPECIFICATIONS

### Mechanical/Electrical

- Product Certifications: UL508A
- Enclosure Rating: Type 4X
- Attic Conduit Pass Through Connector Size Range: 1/2" – 1"
- Max. Side Wall Conduit Size: 1"
- Maximum Current: N/A
- Maximum Voltage: N/A
- Ambient Operating Temperature: –35 to 75°C

### Torque Ratings

**Table T1: Ground Bar Connection, Wire Range: #4 to #14, 4 Usable Connections**

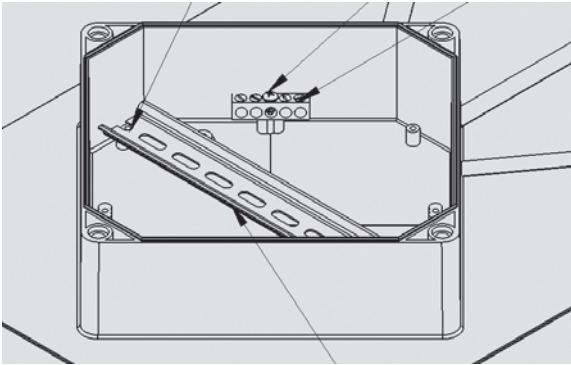

Wire Size	Tightening Torque (lb-in)
AWG	35
8 AWG	30
10–14 AWG	25

**Table T2: Mounting Screw, Mounting to Decking, 2 Provided**

Tightening Torque (lb-in)
15–20

**Table T3: Torque Values, Cover/Lid Screws , 4 Provided, Captive**

Tightening Torque (lb-in)
11

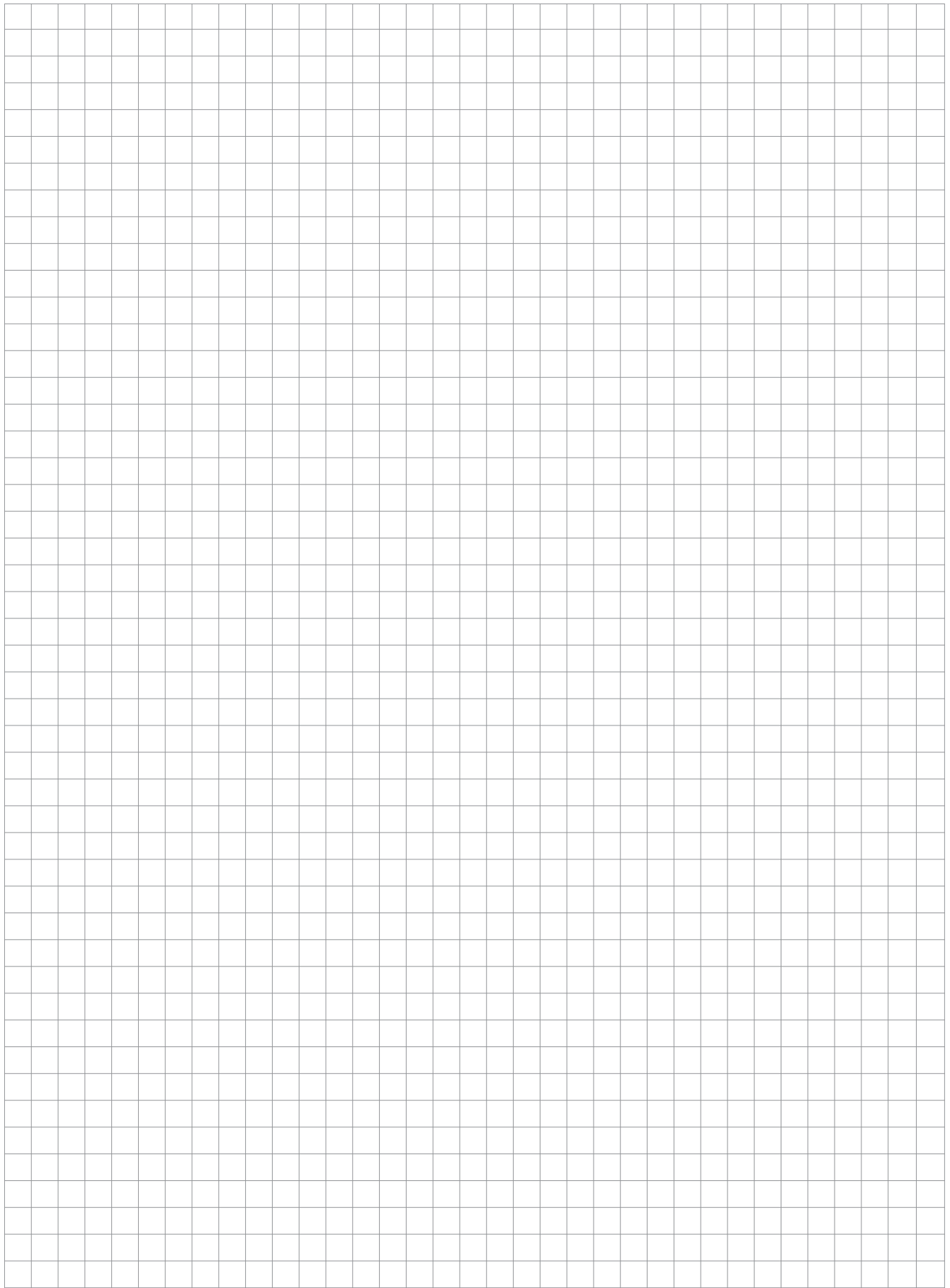

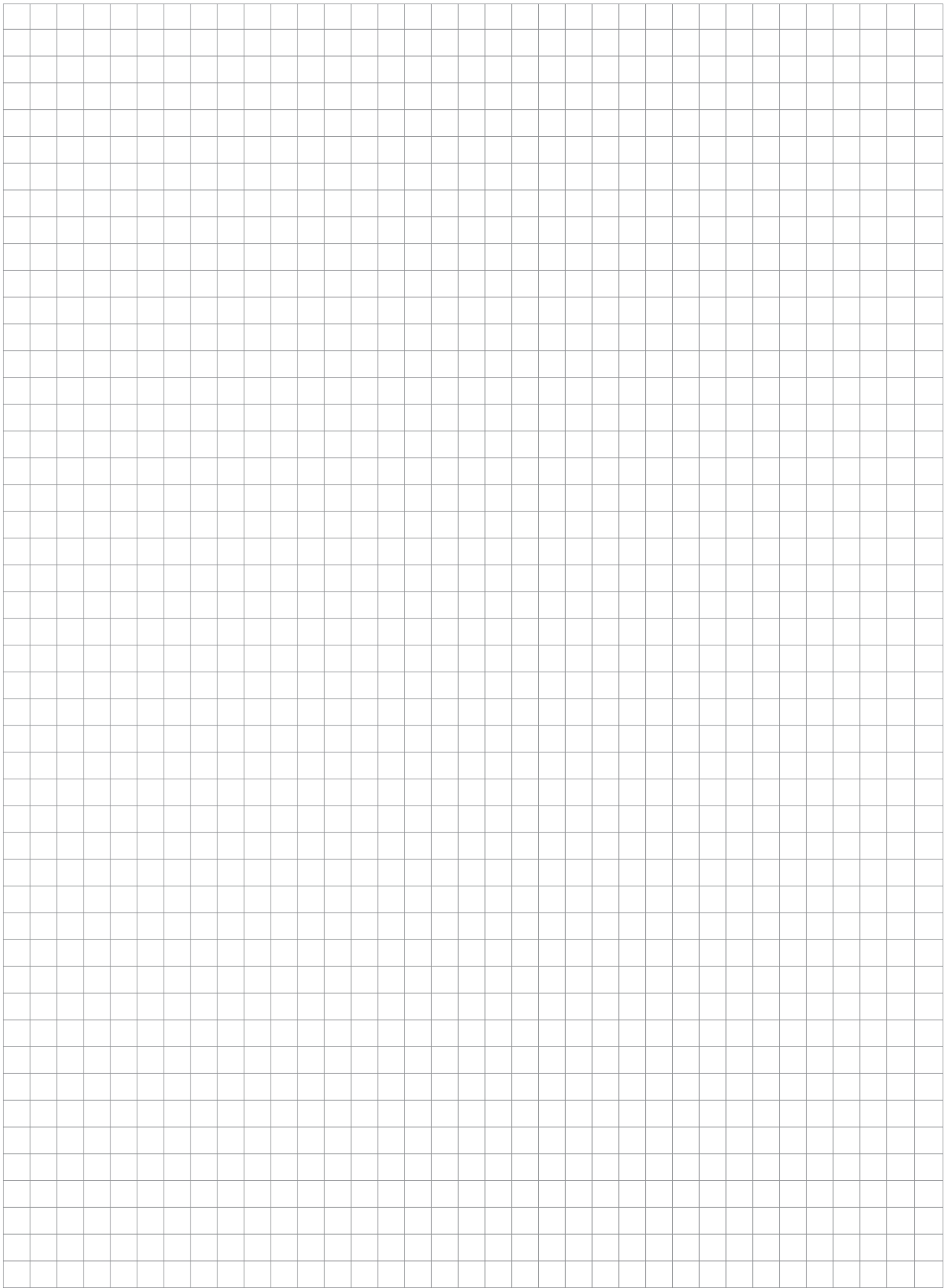

**North America**

Tel +1.800.545.6258  
Fax +1.800.527.5703  
thermal.info@nVent.com

**Europe, Middle East, Africa**

Tel +32.16.213.511  
Fax +32.16.213.604  
thermal.info@nVent.com

**Asia Pacific**

Tel +86.21.2412.1688  
Fax +86.21.5426.3167  
cn.thermal.info@nVent.com

**Latin America**

Tel +1.713.868.4800  
Fax +1.713.868.2333  
thermal.info@nVent.com



[nVent.com/HOFFMAN](http://nVent.com/HOFFMAN)