



**CONNECT AND PROTECT**

# IEC 61439

White Paper



**HOFFMAN**



# Table of contents

<b>1. Introduction</b>	<b>5</b>
<b>2. IEC 61439</b>	<b>6</b>
2.1. Standard structure	6
2.2. Main content	6
2.2.1. Terms and definitions	6
2.2.2. Interface characteristics	6
2.2.3. Service conditions	6
2.2.4. Constructional and performance requirements	7
2.2.5. Design verification	7
2.2.6. Routine verification	7
<b>3. nVent HOFFMAN approach to the IEC 61439</b>	<b>9</b>
3.1. nVent HOFFMAN as empty enclosures supplier	9
3.1.1. Strength of material parts	9
3.1.2. Degree of protection of enclosures	9
3.2. nVent HOFFMAN as "original manufacturer" and assembly system supplier	9
<b>4. nVent HOFFMAN support in the design verification stage</b>	<b>11</b>
4.1. Strength of materials and parts	11
4.2. Degree of protection of enclosures	11
4.3. Clearances and creepage distances	12
4.4. Protection against electric shock and integrity of protective circuits	12
4.5. Incorporation of switching devices and components	13
4.6. Internal electrical circuits and connections	13
4.7. Terminals for external conductors	13
4.8. Dielectric properties	13
4.9. Verification of temperature rise	14
4.10. Short-circuit withstand strength	14
4.11. Electromagnetic compatibility	15
4.12. Mechanical operation	15
<b>5. FAQs (Frequently Asked Questions)</b>	<b>16</b>
<b>6. Annexes</b>	<b>18</b>





# 1. Introduction

**The new standard IEC 61439 “Low-voltage switchgear and control gear assemblies” came into force in November 2014. This standard withdraws the previous standard IEC 60439.**

IEC 61439 describes the definitions and states the service conditions, construction requirements, technical characteristics, and verification requirements for low-voltage switchgear and control gear assemblies.

This standard applies to low-voltage assemblies intended for use in connection with the generation, transmission, distribution and conversion of electric energy, and for the control of electric energy.

## **Need to conform to this standard.**

The CE marking is required for the low-voltage switchgear and control gear assemblies in the European Economic Area. It states that the product is assessed before being placed on the market and meets EU safety, health and environmental protection requirements. The manufacturer must prepare a Declaration of Conformity (CE DoC) and must be able to demonstrate that they have met the Low Voltage Directive, and the way to do that is to comply with the relevant harmonised standards which for electrical panels is at least the IEC 61439.

## **Affected market segments.**

In the past there was the feeling that the IEC 60439 was affecting only to the Power & Distribution panels but all the segments are affected by the new standard (Automation & Control, Machine builders, Building).

nVent HOFFMAN provides the market with enclosure solutions that are part of the assembly, therefore nVent HOFFMAN products are affected directly by the IEC 61439 standard:

- Enclosures
- Busbar supports
- Thermal management equipment



## 2. IEC 61439

### 2.1. Standard structure

### 2.2. Main content

#### 2.2.1. Terms and definitions.

Important definitions to understand the standard are:

- Low-voltage switchgear and control gear assembly: is a combination of one or more switching devices together with associated control, measuring, signalling, protective, regulating equipment, with all the internal electrical and mechanical interconnections and structural parts. We can say that the assemblies are made with: enclosure, operational components, electrical connections, and thermal management components.
- Assembly system: is a full range of mechanical and electrical components (enclosures, busbars, functional units, etc.), as defined by the original manufacturer, which can be assembled in accordance with the original manufacturer's instructions in order to produce various assemblies.
- Original manufacturer: is the organization that has carried out the original design and the associated verification of an assembly in accordance with the relevant assembly standard.
- Assembly manufacturer: is the organization taking the responsibility for the completed assembly. The assembly manufacturer may be a different organisation to the original manufacturer.
- User: is the party who will specify, purchase, use and/or operate the assembly, or someone acting on their behalf.
- Design verification: is the verification made on a sample of an assembly or on parts of assemblies to show that the design meets the requirements of the relevant assembly standard.
- Routine verification: is the verification of each assembly performed during and/or after manufacture to confirm whether it complies with the requirements of the relevant assembly standard.

#### 2.2.2. Interface characteristics

The characteristics of the assembly will ensure compatibility with the ratings of the circuits to which it is connected and the installation conditions, and will be declared by the assembly manufacturer.

- Voltage ratings
- Current ratings
- Rated diversity factor (RDF)
- Rated frequency
- Other characteristics (Special service conditions, pollution degree, ...)

#### 2.2.3. Service conditions

Normal service conditions, assemblies conforming to this standard are intended for use under the defined normal service conditions.

- Ambient air temperature, -5°C to 35°C for indoor, and -25°C to 35°C for outdoor.
- Humidity conditions, less than 50% at 40°C for indoor, and 100% at 25°C for outdoor.
- Pollution degree, for industrial applications usually pollution degree 3
- Altitude, less than 2000 m

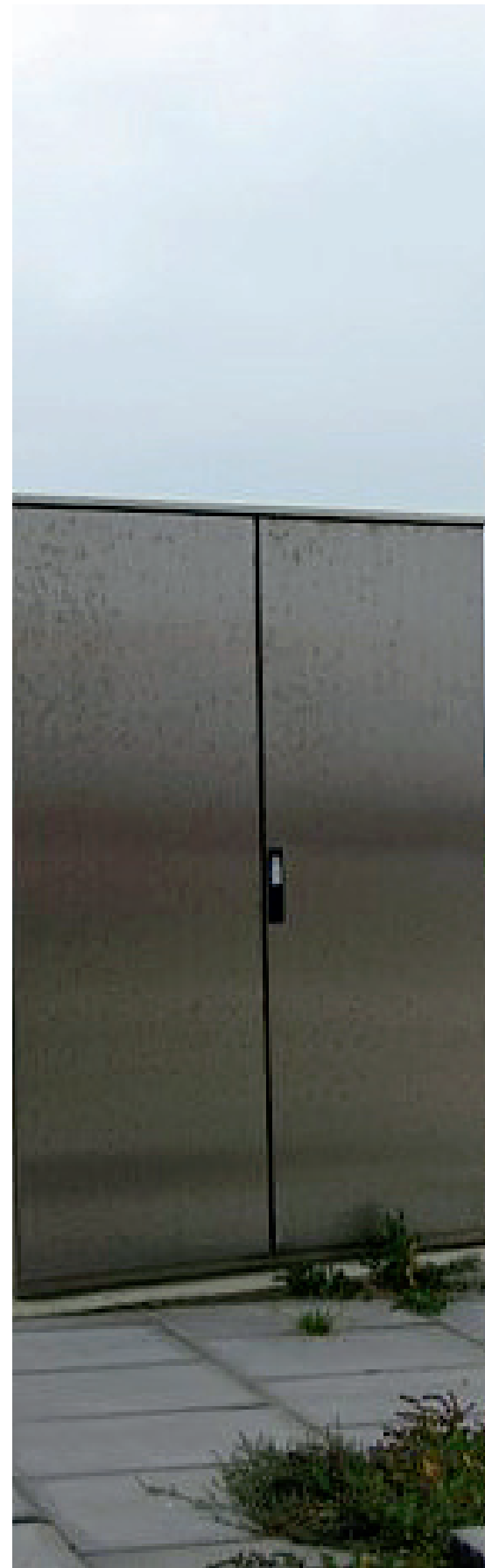



#### 2.2.4. Constructional and performance requirements:

- Strength of materials and parts
- Degree of protection
- Clearances and creepage distances
- Protection against electric shock
- Incorporation of switching devices and components
- Internal electrical circuits and connections
- Cooling
- Terminal for external conductors
- Dielectric properties
- Temperature rise limits
- Short-circuit protection and short-circuit withstand strength
- Electromagnetic compatibility (EMC)

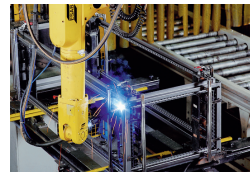

#### 2.2.5. Design verification

Design verification is intended to check the assembly's design compliance with the requirements. There are three verification methods: test, comparison with a tested reference design, and verification assessment.

- Construction features verification
- Performance verification

#### 2.2.6. Routine verification

Routine verification is intended to detect faults in materials and workmanship and determine proper functioning of the manufactured assembly. This verification is made on every assembly.

- Construction features verification
- Performance verification











### 3. nVent HOFFMAN approach to the IEC 61439

#### 3.1. nVent HOFFMAN as empty enclosures supplier

nVent HOFFMAN enclosures must comply with the relevant requirements included in the standard IEC 61439 for enclosures. The relevant requirements for enclosures are included in section 8.1 of the standard "Strength of materials and parts", and in section 8.2 "Degree of protection provided by an assembly enclosure". The design verification for these requirements is explained in sections 10.2 and 10.3, and nVent HOFFMAN supports this verification process in the following way:

##### 3.1.1. Strength of material parts:

The standard states the following "where an empty enclosure in accordance with IEC 62208 is used, and it has not been modified so as to degrade the performance of the enclosure, no repetition of the enclosure testing is required".

##### 3.1.2. Degree of protection of enclosures:

The standard states the following "where an empty enclosure in accordance with IEC 62208 is used, a verification assessment shall be performed to ensure that any external modification that has been carried out does not result in a deterioration of the degree of protection. In this case no further testing is required".

nVent HOFFMAN enclosures have been tested according to the standard IEC 62208 by the independent laboratory KEMA-DEKRA who has issued the certificates, and enclosures are marked with the KEMA KEUR mark. The information about the KEMA-DEKRA certificates is included in Annex 01.

The standard IEC 61439 is for complete assemblies, therefore a certification cannot be issued for empty enclosures according to this standard. However, nVent HOFFMAN can state that:

**"nVent HOFFMAN enclosures comply with the new standard IEC 61439"**

#### 3.2. nVent HOFFMAN as "Original Manufacturer" and assembly system supplier

nVent HOFFMAN, with the EPS assembly system, has manufactured assemblies with different components brands (switches), and these assemblies have been tested by the independent Swedish laboratory Intertek-Semko. Test results have been recorded in the STR (Statement of Test Results) SE-1405658 by Intertek-Semko.

nVent HOFFMAN becomes an "original manufacturer", and in conclusion all assemblies manufactured using the nVent HOFFMAN assembly system and follow the design and manufacturing rules included in the EPS manual; do not need to be tested again. The tested assemblies can be used as a reference design verified by test.

Therefore nVent HOFFMAN can state:

**"nVent HOFFMAN's EPS is a tested assembly system according to IEC 61439"**

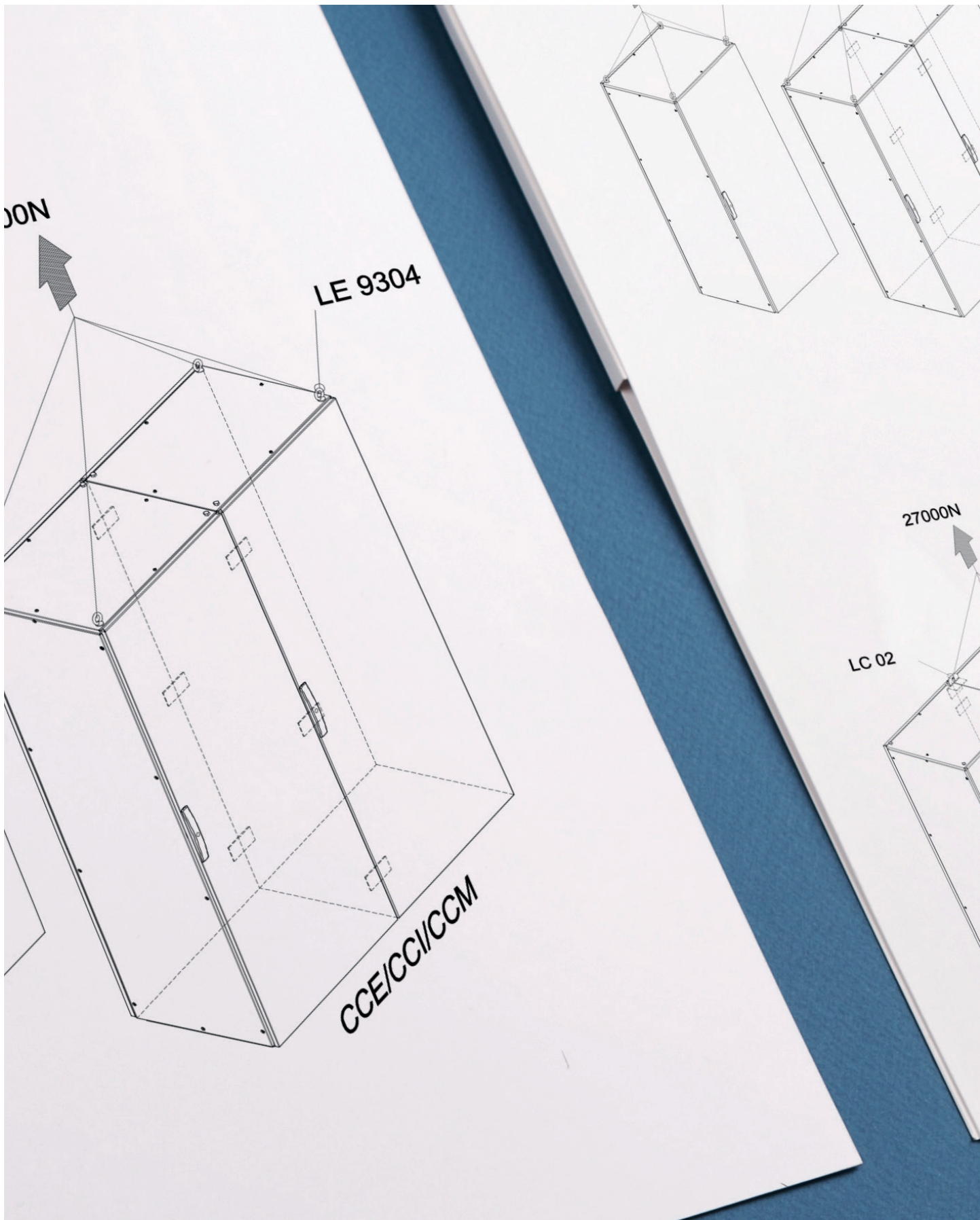



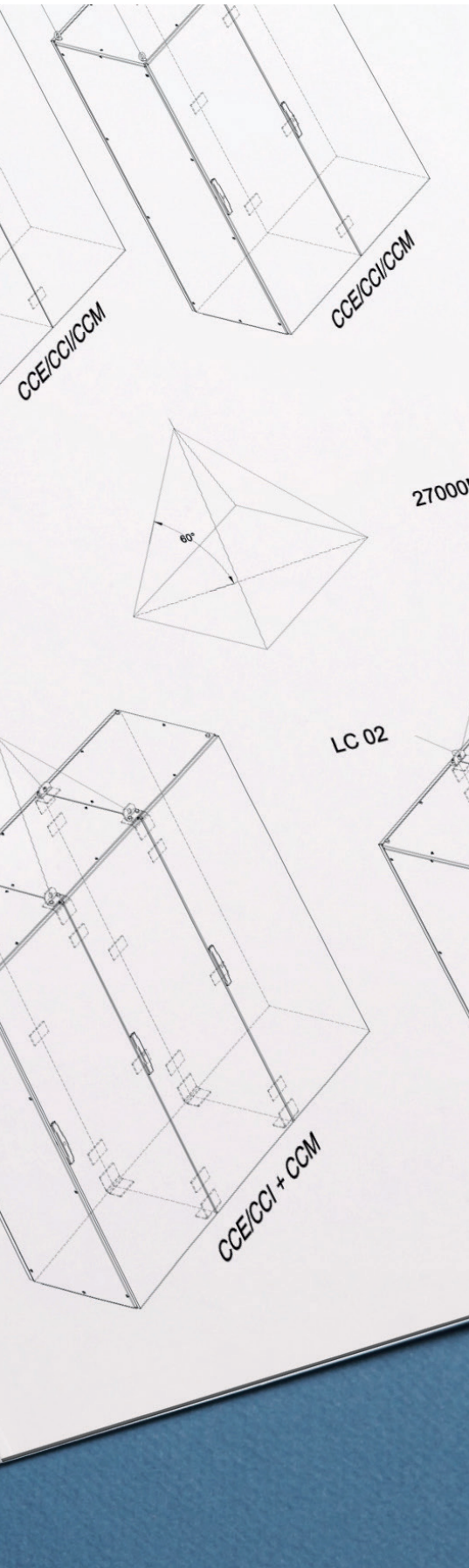

## 4. nVent HOFFMAN support in the design verification stage

nVent HOFFMAN has carried out different tests and developed specific tools to facilitate design verification of the assemblies according to the standard IEC 61439.

The "design verification" comprises of the following verifications:

### 4.1. Strength of materials and parts

Assemblies shall be manufactured of materials capable of withstanding the mechanical, electrical, thermal, and environmental stresses.

The verification includes different tests:

- Resistance to corrosion
- Properties of insulating materials
- Resistance to ultra-violet (UV) radiation
- Lifting
- Mechanical impact
- Marking

nVent HOFFMAN enclosures have been tested and certified according to the IEC 62208:2011 by KEMA-DEKRA. This test lets our customers use the certificate without performing any additional test but only if the enclosure has not been modified in any way so as to degrade the performance of the enclosure.

KEMA-DEKRA certificate details can be found in Annex 01.

### 4.2. Degree of protection of enclosures

The degree of protection provided by the assembly against contact with live parts, ingress of solid foreign bodies and water is indicated by the IP. The protection against mechanical impact, if necessary, shall be defined by the IK.

The accepted verification methods are:

- Testing: nVent HOFFMAN enclosures have been tested and certified according to the IEC 62208:2011 by KEMA-DEKRA. This certification includes the required IP test according to IEC 60529, and the IK test according to IEC 62262
- Assessment: verification assessment shall be performed to ensure that any external modification that has been carried out does not result in a deterioration of the degree of protection, then no further testing is required. KEMA-DEKRA certificate details can be found in Annex 01.



### 4.3. Clearances and creepage distances

The requirements for clearances and creepage distances are intended to provide insulation co-ordination within the installation, and the values are stated by the standard. The only accepted verification method is by testing (measuring) minimum values depending on the voltage, pollution degree, and the material group of insulation materials used.

In the EPS assembly system design verification Intertek-Semko has tested the required clearances and creepage distances for the nVent HOFFMAN affected products as busbar supports and it is recorded in the STR (Statement of Test Results) SE-1405658. Details for the different busbar systems can be found in Annex 02.



### 4.4. Protection against electric shock and integrity of protective circuits

The effectiveness of the protective circuit shall guarantee the protection against the consequences of internal faults through the effective earth continuity between the exposed conductive parts and the protective circuit, and the consequences of external faults through the short-circuit withstand strength of the protective circuit.

There are two verifications included:

- Effective earth continuity: test is the only accepted verification method, and it is exactly the same included in the standard IEC 62208:2011 and nVent HOFFMAN enclosures have passed it. The customers do not require to have further verification for nVent HOFFMAN enclosures and related accessories. KEMA-DEKRA certificate details can be found in Annex 01.
- Short-circuit withstand strength of the protective circuit: verification may be by test or by comparison with a reference design.

Test: KEMA-DEKRA has carried out the short-circuit tests in the different earthing connections of the enclosures and the test results are available for design purposes. KEMA Test report N° 2088000.01, certificate details can be found in Annex 03.

Comparison with a reference design: verification is achieved when comparison following check list included in table 13 of the standard (items 1 to 6 and 8 to 10) between assembly and reference design does not show deviations. KEMA Test report N° 2088000.01 can be used as a reference design, certificate details can be found in Annex 03.

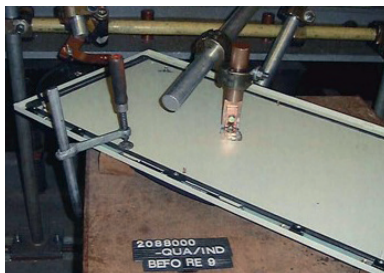
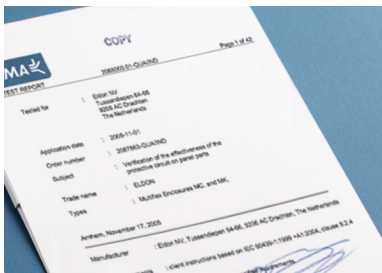





#### 4.5. Incorporation of switching devices and components.

The selection must consider the suitability for the application, the installation must be done following manufacturer instructions and it must follow section 8.5 of the standard. The verification must be done by assessment recording the followed criteria and results.

#### 4.6. Internal electrical circuits and connections.

It must be designed to minimize the possibility of internal short-circuits, and it must follow section 8.6 of the standard. The verification must be done by assessment recording the followed criteria and results.

#### 4.7. Terminals for external conductors.

The selection must consider the suitability of the terminals provided for external connections, and to be suitable for the current rating and short-circuit strength of the system. It must follow section 8.8 of the standard.

The verification must be done by assessment recording the followed criteria and results, and the inspection is made performing a visual inspection.



#### 4.8. Dielectric properties.

Each circuit of the assembly shall be capable of withstanding temporary overvoltages and transient overvoltages:

- The ability to withstand temporary overvoltage's is verified by the "power-frequency withstand voltage", applicable to the main and auxiliary circuits following section 9.1.2 of the standard. The verification must be done by test, and Intertek-Semko has tested it in the EPS assembly system and it is recorded in the STR (Statement of Test Results) SE-1405658. Details for the tested voltages can be found in Annex 02.
- The ability to withstand transient overvoltage's is verified by the "impulse withstand voltage", applicable to the main and auxiliary circuits following section 9.1.3 of the standard. The verification must be made by test or by assessment:

Test: Intertek-Semko has tested it in the EPS assembly system and it is recorded in the STR (Statement of Test Results) SE-1405658. Details for the tested voltages can be found in Annex 02.

Assessment: Measuring the clearances (increased by a margin of 50%). In the EPS assembly system design verification Intertek-Semko has verified the clearances in air for the nVent HOFFMAN affected products as busbar supports and it is recorded in the STR (Statement of Test Results) SE-1405658. Details for the different busbar systems can be found in Annex 02. These measurements can be used for the verification assessment.

### 4.9. Verification of temperature rise

The maximum temperature rises let in the assembly with ambient temperature up to 35°C are specified in section 9.2 of the standard.

For verification purposes the RDF (Rated Diversity Factor) must be taken in consideration, and the standard grants three methods of verification:

- Testing: applicable in all assemblies.
- Derivation: complying with the rules included in section 10.10.3 of the standard rated currents of variants can be verified by derivation from similar arrangements verified by test. In the EPS assembly system with different brands and sizes of switches Intertek-Semko has tested the temperature rise, and the results have been recorded in the STR (Statement of Test Results) SE-1405658. These values have been used to create temperature rise tables which let to our customers to make derivations avoiding the test.
- Calculation depending on the design and rated current:

Single compartment with rated current not exceeding 630A, complying with conditions in section 10.10.4.2.1 of the standard. Confirmation that the power losses inside the enclosure do not exceed the power dissipation capability of the enclosure. To use this calculation the continuous load of the components does not need to exceed more than 80% of its rated current. nVent HOFFMAN provides Thermal management software to make the verification in these conditions easier.

Assembly with rated current not exceeding 1600A, complying with conditions in section 10.10.4.3.1 of the standard.

The temperature rise verification can be made by calculation in accordance with the method of IEC 60890 from the total power losses inside the enclosure. To use this calculation the continuous load of the components does not need to exceed more than 80% of its rated current. nVent HOFFMAN has software available to apply the standard verification in these conditions easier.

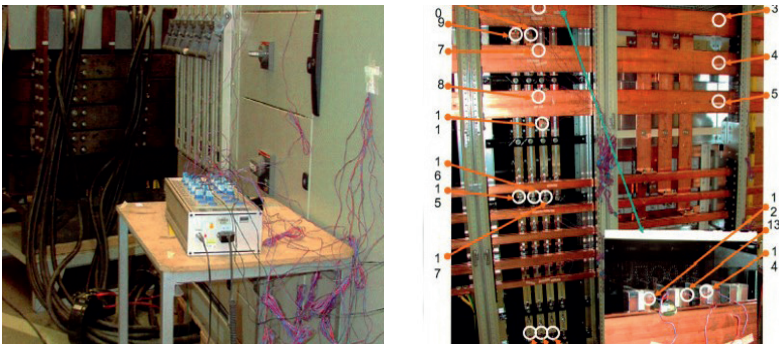

### 4.10. Short-circuit withstand strength

Confirmation that the assembly will be able to withstand thermal and dynamic stresses resulting from short-circuits currents. Section 10.11.2 of the standard states the exempted circuits, for example when the prospective short-circuit current at the incoming terminals does not exceed 17 kA cut-off / 10 kA r.m.s.

There are available two methods of verification:

- Verification by test. The test must be carried out following section 10.11.5 of the standard.
- Verification by comparison with a reference design. This comparison can be made using a check list or calculation:

Check list: verification is made comparing the verified assembly to the already tested design using the check list in the table 13 of the standard.

Calculation: verification is made comparing the verified assembly to the already tested design in accordance with Annex P of the standard and checking that each circuit meet the requirements of part of the check list in the table 13 of the standard (6, 8, 9, 10).

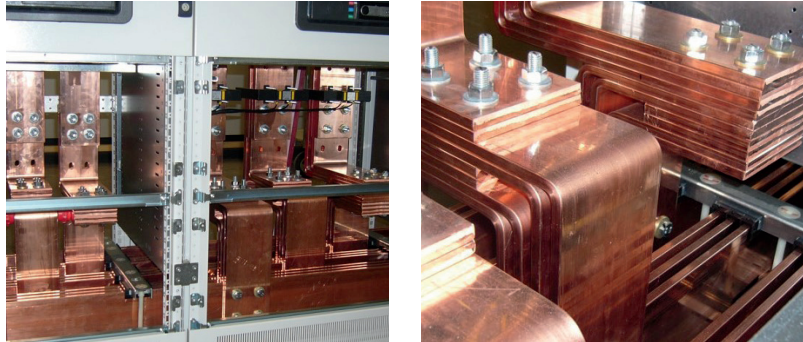

Using as a reference design the assemblies tested by Intertek-Semko, nVent HOFFMAN has created the design tables for the different busbar supports. Following the rules in this tables our customers can design derivations which will comply with the standard and making possible a short-circuit verification by comparison with a reference design using calculation. The design tables are included in Annex 04.

#### 4.11. Electromagnetic compatibility

The standard considers two possible environments (A and B) based in the EMC requirements, and the assembly manufacturer will declare which environment is the assembly suitable for. No EMC tests are required on final assemblies if the following conditions are fulfilled:

- Incorporated components comply with the relevant EMC product standards.
- Installation and wiring has been made following the component manufacturers mounting instructions.
- Two methods of verification are available:
- Verification by test: the test must be carried out following Annex J of the standard.
- Verification by assessment: no EMC tests are required on final assemblies if the following conditions are fulfilled:

Incorporated components complies with the relevant EMC product standards

Installation and wiring has been made following the component manufacturers mounting instructions

In normal conditions the verification will be done by assessment of the component's technical information and how the installation and wiring has been made.

#### 4.12. Mechanical operation

The mechanical operation verification can only be made by test following section 10.13 of the standard. This verification test will not be applied on components which have already been type tested according to their relevant product standard, unless their mechanical operation have been modified during mounting.

nVent HOFFMAN enclosures have been tested according to their relevant product standard, IEC62208, and if all other components have been tested too, no additional tests are required.

## 5. FAQ's (Frequently Asked Questions)

### New standard and evolution

#### **What are the reasons for the new standard?**

The main reasons for the standard revision are the following:

- The IEC 60439 standard is difficult to understand and apply, without clear content and open to subjective interpretations.
- Difficult compliance verification with the concepts "Type Tested Assemblies" and "Partially Type Tested Assemblies" (TTA – PTTA).
- Old standard structure is not representing the current situation.

### Scope of the standard

#### **Is this standard applicable to all electrical panels?**

No, it is applicable only to low-voltage switchgear and controlgear assemblies, but this does not mean that other relevant standards for specific applications must not be complied with.

#### **Is the standard only applicable to Power & Distribution panels?**

No, different parts of the standard corresponds to different electrical panel typologies. For example part 2 corresponds to "Power switchgear and controlgear assemblies", and part 3 corresponds to "Distribution boards". It includes the control panels installed in automation and control processes, or in machines.

### Stakeholders and their role

#### **To which stakeholders is the new standard referring to?**

- User: party who will specify, purchase, use and/or operate the assembly
- Original manufacturer: organization that has carried out the original design
- Assembly manufacturer: organization taking the responsibility of the final assembly following the original design

#### **Who is responsible for what?**

- The user: is responsible to provide all the relevant information about the assembly purpose to make the correct design feasible. The standard includes a part (IEC61439-0) with all details that should be provided in a complete specification.
- Original manufacturer: is responsible to carry out the design verification of the assembly.
- Assembly manufacturer: responsible to follow the original design specifications and carry out the routine verification.



## Standard compliance

### **Is the compliance with this standard obligatory?**

The assembly compliance with this standard is the easiest way to comply with the applicable EC Directives (EMC and Low-Voltage), which are required to put the CE mark in the assembly.

### **Can nVent HOFFMAN certify his products according to the IEC 61439 standard?**

No, nVent HOFFMAN is not providing switchboard or controlgear assemblies, then nVent HOFFMAN can not make a certificate for his products according to this standard. nVent HOFFMAN is offering the certificate for his products (empty enclosures) according to the relevant standard for this type of products "IEC 62208, Empty enclosures for low-voltage switchgear and controlgear assemblies".

### **Is nVent HOFFMAN providing the IEC 61439 certificate for their empty enclosures?**

No, it is not possible because the standard compliance must be stated by the design and routine verification which must be done for the complete enclosure and taking in consideration the application.

### **Do nVent HOFFMAN enclosures comply with the IEC 61439 standard?**

Yes, because nVent HOFFMAN enclosures have been tested according to the IEC 62208 and it covers the IEC 61439 relevant requirements for the enclosures. On top of that the nVent HOFFMAN certificate about the IEC 62208 lets to our customers use this certificate and avoid further verifications about:

- Strength of material and parts
- Degree of protection of enclosures

nVent HOFFMAN is providing a Declaration of Compliance of the enclosures with the relevant requirements stated in the standard IEC 61439-1&2 for the empty enclosures.

### **The tests already carried out according to the old standard IEC 60439 must be repeated?**

No, the tests conducted in accordance with IEC 60439, fulfil the requirements of the relevant part of IEC 61439, and they don't need to be repeated. For example the temperature rise tests carried out by nVent HOFFMAN for the EPS system, or the short-circuit tests carried out for the enclosures earthing connections, can be used for the design verification of new designs.

### **nVent HOFFMAN enclosures with filter fans mounted in our factory comply with the standard?**

The assembly of filter fans and exhaust filters can affect the IP and IK of the enclosures, and enclosure values must be updated according to the filter fans information. The components selected in accordance with the standard, and installed following the manufacturer's mounting instructions, can avoid the repetition of component verifications. The verification of the assembly about the degree of protection can be made by "verification assessment" taking in consideration the degree of protection provided by the filter fans and exhaust filters.

# Annex 01

## KEMA-DEKRA Certificate

KEMA-DEKRA declares in the below certificates that the product ranges included have been certified on the basis of a type test according to the standard IEC 62208:2011.

**KEMA-DEKRA Certificate N° 2171237-01** includes the following product ranges:

Wall mounted enclosures: **MAS, MAD, MAP, ASR, ADR, AFS**

Floor standing enclosures: **MCS, MCD, MKS, MKD, MCSS, MCDS**

### **MAS, Mild steel wall mounted enclosure, single door**

- Method of fixing: Wall mounted
- Type of material: Powder painted steel
- Intended location: Indoor (severity corrosion test A)
- Resistance to ultra-violet radiation: N/A because is intended for indoor locations
- Lifting: N/A
- Degree of protection, mechanical impact: IK10
- Degree of protection, solids and liquids: IP66

### **ASR, Stainless steel wall mounted enclosure, single door**

- Method of fixing: Wall mounted
- Type of material: Stainless steel
- Intended location: Outdoor (severity corrosion test B)
- Resistance to ultra-violet radiation: N/A because is not powder coated
- Lifting: N/A
- Degree of protection, mechanical impact: IK10
- Degree of protection, solids and liquids: IP66

### **MCS, Mild steel floor standing enclosure, single door**

- Method of fixing: Floor standing
- Type of material: Powder painted steel
- Intended location: Indoor (severity corrosion test A)
- Resistance to ultra-violet radiation: N/A because is intended for indoor locations
- Lifting: With lifting eyes LE, 3400 N 45° max  
With lifting devices LC, 6750N 45° max
- Degree of protection, mechanical impact: IK10
- Degree of protection, solids and liquids: IP55

### **MAD, Mild steel wall mounted enclosure, double door**

- Method of fixing: Wall mounted
- Type of material: Powder painted steel
- Intended location: Indoor (severity corrosion test A)
- Resistance to ultra-violet radiation: N/A because is intended for indoor locations
- Lifting: N/A
- Degree of protection, mechanical impact: IK10
- Degree of protection, solids and liquids: IP55

### **ADR, Stainless steel wall mounted enclosure, double door**

- Method of fixing: Wall mounted
- Type of material: Stainless steel
- Intended location: Outdoor (severity corrosion test B)
- Resistance to ultra-violet radiation: N/A because is not powder coated
- Lifting: N/A
- Degree of protection, mechanical impact: IK10
- Degree of protection, solids and liquids: IP55

### **MCD, Mild steel floor standing enclosure, double door**

- Method of fixing: Floor standing
- Type of material: Powder painted steel
- Intended location: Indoor (severity corrosion test A)
- Resistance to ultra-violet radiation: N/A because is intended for indoor locations
- Lifting: With lifting eyes LE, 3400 N 45° max  
With lifting devices LC, 6750N 45° max
- Degree of protection, mechanical impact: IK10
- Degree of protection, solids and liquids: IP55

### **MAP, Mild steel wall mounted enclosure, panel**

- Method of fixing: Wall mounted
- Type of material: Powder painted steel
- Intended location: Indoor (severity corrosion test A)
- Resistance to ultra-violet radiation: N/A because is intended for indoor locations
- Lifting: N/A
- Degree of protection, mechanical impact: IK10
- Degree of protection, solids and liquids: IP55

### **AFS, Stainless steel wall mounted enclosure, single door & sloping roof**

- Method of fixing: Wall mounted
- Type of material: Stainless steel
- Intended location: Outdoor (severity corrosion test B)
- Resistance to ultra-violet radiation: N/A because is not powder coated
- Lifting: N/A
- Degree of protection, mechanical impact: IK10
- Degree of protection, solids and liquids: IP66

### **MKS, Mild steel compact floor standing enclosure, single door**

- Method of fixing: Floor standing
- Type of material: Powder painted steel
- Intended location: Indoor (severity corrosion test A)
- Resistance to ultra-violet radiation: N/A because is intended for indoor locations
- Lifting: With lifting eyes LE, 3400 N 45° max
- Degree of protection, mechanical impact: IK10
- Degree of protection, solids and liquids: IP55

**MCSS, Stainless steel floor standing enclosure, single door**

- Method of fixing: Floor standing
- Type of material: Powder painted steel
- Intended location: Outdoor (severity corrosion test B)
- Resistance to ultra-violet radiation: N/A because is not powder coated
- Lifting: With lifting eyes LE, 3400 N 45° max  
With lifting devices LC, 6750N 45° max
- Degree of protection, mechanical impact: IK10
- Degree of protection, solids and liquids: IP55

**MCDS, Stainless steel floor standing enclosure, double door**

- Method of fixing: Floor standing
- Type of material: Powder painted steel
- Intended location: Outdoor (severity corrosion test B)
- Resistance to ultra-violet radiation: N/A because is not powder coated
- Lifting: With lifting eyes LE, 3400 N 45° max  
With lifting devices LC, 6750N 45° max
- Degree of protection, mechanical impact: IK10
- Degree of protection, solids and liquids: IP55

**MKD, Mild steel compact floor standing enclosure, double door**

- Method of fixing: Floor standing
- Type of material: Powder painted steel
- Intended location: Indoor (severity corrosion test A)
- Resistance to ultra-violet radiation: N/A because is intended for indoor locations
- Lifting: With lifting eyes LE, 3400 N 45° max  
Degree of protection, mechanical impact: IK10
- Degree of protection, solids and liquids: IP55

**KEMA-DEKRA Certificate N° 2171237-02** includes the following product ranges:  
Floor standing enclosures: **EKSS, EKDS**

**EKSS, Stainless steel compact floor standing enclosure, single door**

- Method of fixing: Floor standing
- Type of material: Powder painted steel
- Intended location: Outdoor (severity corrosion test B)
- Resistance to ultra-violet radiation: N/A because is not powder coated
- Lifting: With lifting eyes LE, 3400 N 45° max
- Degree of protection, mechanical impact: IK10
- Degree of protection, solids and liquids: IP66

**EKDS, Stainless steel compact floor standing enclosure, double door**

- Method of fixing: Floor standing
- Type of material: Powder painted steel
- Intended location: Outdoor (severity corrosion test B)
- Resistance to ultra-violet radiation: N/A because is not powder coated
- Lifting: With lifting eyes LE, 3400 N 45° max
- Degree of protection, mechanical impact: IK10
- Degree of protection, solids and liquids: IP55

**KEMA-DEKRA Certificate N° 2171237-03** includes the following product ranges:  
Terminal boxes: **STB, SSTB**

**STB, Mild steel terminal box**

- Method of fixing: Wall mounted
- Type of material: Powder painted steel
- Intended location: Indoor (severity corrosion test A)
- Resistance to ultra-violet radiation: N/A because is intended for indoor locations
- Lifting: N/A
- Degree of protection, mechanical impact: IK10
- Degree of protection, solids and liquids: IP66

**SSTB, Stainless steel terminal box**

- Method of fixing: Wall mounted
- Type of material: Stainless steel
- Intended location: Outdoor (severity corrosion test B)
- Resistance to ultra-violet radiation: N/A because is not powder coated  
Lifting: N/A
- Degree of protection, mechanical impact: IK10
- Degree of protection, solids and liquids: IP66

# Annex 02

## Intertek-Semko Statement of Test Result ( STR )

Below, you can find the test results details included in the issued STR (Statement of Test Results) SE-1405658 by Intertek-Semko. The tests have been carried out according to the standard IEC 61439.

### Clearances and Creepage distance

Horizontal busbar system nVent HOFFMAN MSHS	Horizontal busbar system nVent HOFFMAN EUBS	Horizontal busbar system nVent HOFFMAN MSFH	Horizontal busbar system nVent HOFFMAN MSVH	Horizontal busbar system nVent HOFFMAN ECBS
<ul style="list-style-type: none"> <li>Rated impulse withstand voltage: 8 kV</li> <li>Measured clearances: <math>\geq 12</math> mm</li> <li>Rated insulation voltage: 800 V</li> <li>Pollution degree 3</li> <li>Material group IIIa</li> <li>Measured creepage distances: <math>\geq 12,5</math> mm</li> </ul>	<ul style="list-style-type: none"> <li>Rated impulse withstand voltage: 6 kV</li> <li>Measured clearances: <math>\geq 8,5</math> mm</li> <li>Rated insulation voltage: 1000 V</li> <li>Pollution degree 3</li> <li>Material group IIIa</li> <li>Measured creepage distances: <math>\geq 16</math> mm</li> </ul>	<ul style="list-style-type: none"> <li>Rated impulse withstand voltage: 8 kV</li> <li>Measured clearances: <math>\geq 12</math> mm</li> <li>Rated insulation voltage: 1000 V</li> <li>Pollution degree 3</li> <li>Material group IIIa</li> <li>Measured creepage distances: <math>\geq 16</math> mm</li> </ul>	<ul style="list-style-type: none"> <li>Rated impulse withstand voltage: 8 kV</li> <li>Measured clearances: <math>\geq 12</math> mm</li> <li>Rated insulation voltage: 1000 V</li> <li>Pollution degree 3</li> <li>Material group IIIa</li> <li>Measured creepage distances: <math>\geq 16</math> mm</li> </ul>	<ul style="list-style-type: none"> <li>Rated impulse withstand voltage: 8 kV</li> <li>Measured clearances: <math>\geq 12</math> mm</li> <li>Rated insulation voltage: 1000 V</li> <li>Pollution degree 3</li> <li>Material group IIIa</li> <li>Measured creepage distances: <math>\geq 16</math> mm</li> </ul>

### Power-frequency withstand voltage

- Semko test report 615772-1
- Voltage tested: 3kV
- Test voltage required for rated insulation voltage (Ui) up to 1000V: 2,2 kV

### Impulse withstand voltage, test verification

- EPS assembly system
  - Impulse withstand voltage: 7,4 kV

### Impulse withstand voltage, verification assessment

Horizontal busbar system nVent HOFFMAN MSHS	Horizontal busbar system nVent HOFFMAN EUBS	Horizontal busbar system nVent HOFFMAN MSFH	Horizontal busbar system nVent HOFFMAN MSVH	Horizontal busbar system nVent HOFFMAN ECBS
<ul style="list-style-type: none"> <li>Impulse withstand voltage: 8 kV</li> <li>Minimum required clearance in air for 8 kV for verification assessment (1,5 times value in Table 1): <math>8 \text{ mm} \times 1,5 = 12 \text{ mm}</math></li> <li>Measured clearances: <math>\geq 12</math> mm</li> </ul>	<ul style="list-style-type: none"> <li>Impulse withstand voltage: 6 kV</li> <li>Minimum required clearance in air for 8 kV for verification assessment (1,5 times value in Table 1): <math>5,5 \text{ mm} \times 1,5 = 8,25 \text{ mm}</math></li> <li>Measured clearances: <math>\geq 10</math> mm</li> </ul>	<ul style="list-style-type: none"> <li>Impulse withstand voltage: 8 kV</li> <li>Minimum required clearance in air for 8 kV for verification assessment (1,5 times value in Table 1): <math>8 \text{ mm} \times 1,5 = 12 \text{ mm}</math></li> <li>Measured clearances: <math>\geq 12</math> mm</li> </ul>	<ul style="list-style-type: none"> <li>Impulse withstand voltage: 8 kV</li> <li>Minimum required clearance in air for 8 kV for verification assessment (1,5 times value in Table 1): <math>8 \text{ mm} \times 1,5 = 12 \text{ mm}</math></li> <li>Measured clearances: <math>\geq 12</math> mm</li> </ul>	<ul style="list-style-type: none"> <li>Impulse withstand voltage: 8 kV</li> <li>Minimum required clearance in air for 8 kV for verification assessment (1,5 times value in Table 1): <math>8 \text{ mm} \times 1,5 = 12 \text{ mm}</math></li> <li>Measured clearances: <math>\geq 12</math> mm</li> </ul>



# Annex 03

## KEMA Test Report N°2088000.01

Below, you can find the test results details included in the KEMA Test report N°2088000.01.

### Earthing stud M8

#### Test conditions

- Cable section: 35 mm<sup>2</sup>
- Torque: 15 Nm

#### Test results

- Short-time withstand current (I<sub>cw</sub>): 17,7 kA during 71 ms
- Peak withstand current (I<sub>pk</sub>): 35,3 kA

### Earthing mounting plate connection M8

#### Test conditions

- Cable section: 35 mm<sup>2</sup>
- Torque: 15 Nm

#### Test results

- Short-time withstand current (I<sub>cw</sub>): 20,5 kA during 62 ms
- Peak withstand current (I<sub>pk</sub>): 40,7 kA

### Earthing floor standing enclosures bottom plate connection M6

#### Test conditions

- Cable section: 25 mm<sup>2</sup>
- Torque: 15 Nm

#### Test results

- Short-time withstand current (I<sub>cw</sub>): 10,7 kA during 61 ms
- Peak withstand current (I<sub>pk</sub>): 21,2 kA

# Annex 04

nVent HOFFMAN Busbar Supports short-circuit withstand strength.

## ECBS, Compact Busbar Supports

ECBS205TN								
	mm		I <sub>pk</sub> KA I <sub>cc</sub> rms KA 1s					
			11	24	48	63	82	114
			6,5	12	23	30	39	52
1 bar per phase	25	5	1000	477	237	182	140	100
	30	5	1000	525	261	200	154	110
	40	5	1000	614	305	234	180	114
	50	5	1000	696	346	265	204	117
	63	5	1000	797	365	303	233	122
	80	5	1000	924	367	347	250	129
2 bars per phase	25	5	894	411	204	156	120	86
	30	5	1000	465	231	177	136	97
	40	5	1000	568	282	216	166	119
	50	5	1000	666	331	254	195	139
	63	5	1000	789	378	300	231	160
	80	5	1000	944	382	356	276	169

ECBS110TN								
	mm		I <sub>pk</sub> KA I <sub>cc</sub> rms KA 1s					
			11	24	48	63	82	
			6,5	12	23	30	39	
1 bar per phase	25	10	1000	918	456	349	269	
	30	10	1000	1000	502	385	296	
	40	10	1000	1000	512	451	314	
	50	10	1000	1000	513	470	324	
	60	10	1000	1000	516	481	336	
	80	10	1000	1000	520	492	356	

**EUBS, Universal Busbar Support**

<b>EUBS110TN</b>													
	mm		Ipk KA <sub>acc</sub> rms KA 1s										
			24	48	63	82	114	145	152	165	187	209	
			12	23	30	39	52	66	69	75	85	95	
<b>1 bar per phase</b>	30	10	1000	540	414	318	228	179	172	158	129	103	
	40	10	1000	630	483	372	266	209	200	169	132	105	
	50	10	1000	714	530	421	301	224	205	173	135	108	
	60	10	1000	793	532	467	334	230	211	178	139	111	
	80	10	1000	943	537	503	377	245	224	189	147	118	
	100	10	1000	1000	543	506	393	261	239	202	157	126	
	120	10	1000	1000	548	510	410	278	254	215	167	134	
<b>EUBS210TN</b>													
	mm		Ipk KA <sub>acc</sub> rms KA 1s										
			24	48	63	82	114	145	152	165	187	209	231
			12	23	30	39	52	66	69	75	85	95	105
<b>1 bar per phase</b>	30	10	1000	672	515	396	283	223	214	196	173	155	140
	40	10	1000	780	598	460	329	259	248	228	201	180	163
	50	10	1000	877	672	517	370	291	279	256	226	202	167
	60	10	1000	967	741	540	408	321	307	283	249	207	169
	80	10	1000	1000	869	543	478	377	360	332	267	213	175
	100	10	1000	1000	989	546	501	417	393	352	276	221	181
	120	10	1000	1000	1000	555	503	427	403	361	287	230	188
<b>2 bars per phase</b>	30	10	1000	571	438	337	241	190	181	167	147	132	119
	40	10	1000	685	525	404	289	227	218	200	176	158	143
	50	10	1000	792	607	467	334	263	252	232	204	183	165
	60	10	1000	896	687	528	378	298	285	262	231	207	187
	80	10	1000	1000	838	644	461	363	347	320	282	252	228
	100	10	1000	1000	982	755	523	426	407	375	331	296	264
	120	10	1000	1000	1000	863	526	487	465	428	378	335	274
<b>EUBS310TN</b>													
	mm		Ipk KA <sub>acc</sub> rms KA 1s										
			24	48	63	82	114	145	152	165	187	209	231
			12	23	30	39	52	66	69	75	85	95	105
<b>1 bar per phase</b>	30	10	1000	672	515	396	283	223	214	196	173	155	140
	40	10	1000	780	598	460	329	259	248	228	201	180	163
	50	10	1000	877	672	517	370	291	279	256	226	202	178
	60	10	1000	967	741	546	408	321	307	283	249	221	180
	80	10	1000	1000	869	549	478	377	360	332	284	228	186
	100	10	1000	1000	989	569	504	429	410	367	295	236	193
	120	10	1000	1000	1000	592	506	446	420	377	306	245	200
<b>2 bars per phase</b>	30	10	1000	571	438	337	241	190	181	167	147	132	119
	40	10	1000	685	525	404	289	227	218	200	176	158	143
	50	10	1000	792	607	467	334	263	252	232	204	183	165
	60	10	1000	896	687	528	378	298	285	262	231	207	187
	80	10	1000	1000	838	644	461	363	347	320	282	252	219
	100	10	1000	1000	982	755	513	426	407	375	331	278	228
	120	10	1000	1000	1000	863	516	487	465	420	357	289	237
<b>3 bars per phase</b>	30	10	1000	685	525	404	289	228	218	200	177	158	143
	40	10	1000	816	625	481	344	271	259	238	210	188	170
	50	10	1000	939	720	554	396	312	298	275	242	217	196
	60	10	1000	1000	811	615	446	351	336	309	273	244	208
	80	10	1000	1000	984	637	510	427	408	375	330	264	216
	100	10	1000	1000	1000	662	512	481	453	406	343	274	224
	120	10	1000	1000	1000	1000	515	491	466	417	354	286	234



## Annex

### MSHS, Main Busbar Support Short-circuit withstand current (kA)

Distance between supports						Part No.
600 mm			800 mm			
Peak	RMS 1s	RMS 3s	Peak	RMS 1s	RMS 3s	
97	44	28	73	33	28	MSHS403010
105	48	30	79	36	30	MSHS404010
123	56	35	92	42	35	MSHS405010
132	56	35	92	42	35	MSHS406010
132	60	40	106	48	40	MSHS408010
132	60	45	119	54	45	MSHS410010
132	60	50	132	60	50	MSHS412010

### MSFH, Vertical rear busbar support Short-circuit withstand current (kA)

Distance between supports									Part No.
300 mm			400 mm			600 mm			
Peak	RMS 1s	RMS 3s	Peak	RMS 1s	RMS 3s	Peak	RMS 1s	RMS 3s	
53	35	25	63	30	30	53	25	25	Front support
74	50	35	90	43	30	74	35	25	Front and rear supports



Our powerful portfolio of brands:

**CADDY   ERICO   HOFFMAN   RAYCHEM   SCHROFF   TRACER**



[eldon.com](http://eldon.com)  
[HOFFMAN.nVent.com](http://HOFFMAN.nVent.com)