

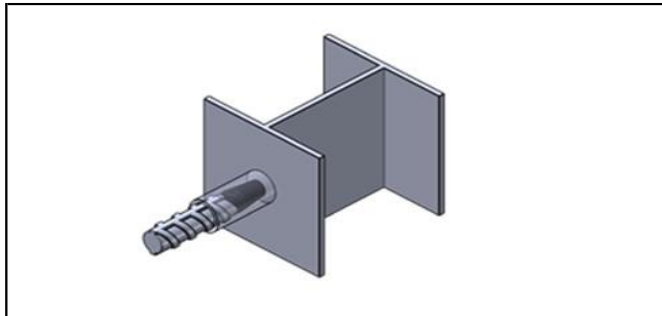

nVent LENTON Installation Instructions

Weldable Couplers - Americas



			Optimal Torque ¹	
in.-lb.	Metric	Canada	Nm	ft.-lbs.
#3	10	---	40	30
#4	12	10M	40	30
---	14	---	80	60
#5	16	15M	120	90
---	18	---	150	110
#6	20	20M	180	130
---	22	---	220	160
---	24	---	270	200
#8	25	25M	270	200
---	26	26M	270	200
#9	28	30M	270	200
---	30	---	300	200*
#10	32	---	300	200*
---	34	---	300	200*
#11	36	35M	300	200*
---	38	---	350	200*
---	40	---	350	200*
#14	43	45M	350	200*
---	50	---	350	200*
#18	57	55M	350	200*

+ Metric and Imperial table values are not a direct conversion

* Americas only

Note 1: Refer to "SNUG Tight Installation Instructions in this document"

WARNING:

- nVent products shall be installed and used only as indicated in nVent product instruction sheets and training materials. Instruction sheets are available at www.nVent.com and from your nVent customer service representative.
- nVent products must never be used for a purpose other than the purpose for which they were designed or in a manner that exceeds specified load ratings.
- All instructions must be completely followed to ensure proper and safe installation and performance.
- Improper installation, misuse, misapplication, or other, failure to completely follow nVent's instructions and warnings may cause product malfunction, property damage, serious bodily injury, and/or death, and void your warranty.

The customer is responsible for:

- Conformance to all governing codes.
- The integrity of structures to which the products are attached, including their capability of safely accepting the loads imposed, as evaluated by a qualified engineer.
- Using appropriate industry standard hardware as noted above.

SAFETY INSTRUCTIONS:

All governing codes and regulations and those required by the job site must be observed.

Always use appropriate safety equipment such as eye protection, hard hat, and gloves as appropriate to the application.

nVent recommends a qualified engineer review all weld joint design data requirements including selection of weld filler material and procedure per local guidelines and recommendations.

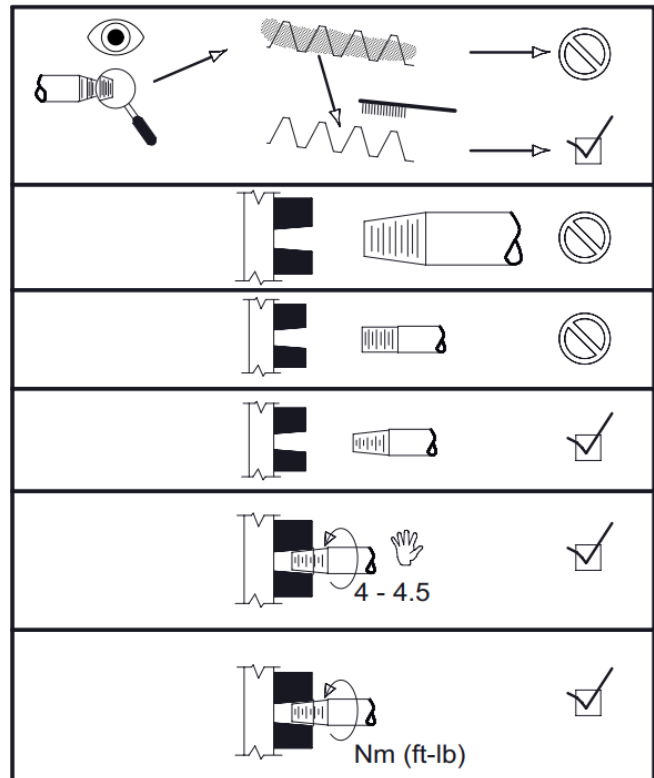

SNUG Tight Installation Instructions: SNUG Tight installation (>5 ft-lbs) may be used with ASTM A615 or A706 Grade 60 and Grade 80 rebar for commercial projects when splice performance requirements are limited to only ACI 318 Type 1 (125% Specified Yield) or Type 2 (Specified Tensile), or when otherwise approved by the project. Additional steps may be necessary to secure product for transportation and handling.

nVent, nVent CADDY, nVent ERICO Cadweld, nVent ERICO Critec, nVent ERICO, nVent EIRFLEX, and nVent LENTON are registered trademarks of nVent or its global affiliates. All other trademarks are the property of their respective owners. nVent reserves the right to change specifications without prior notice.



TECHNICAL SUPPORT:
www.nVent.com

IPNAWC01

1 of 1

© 2005 – 2023 nVent All Rights Reserved

