

Floor standing enclosures Combinable one glazed door and swingframe

MOUNTING INSTRUCTIONS

7697-0318-02 REV. 0

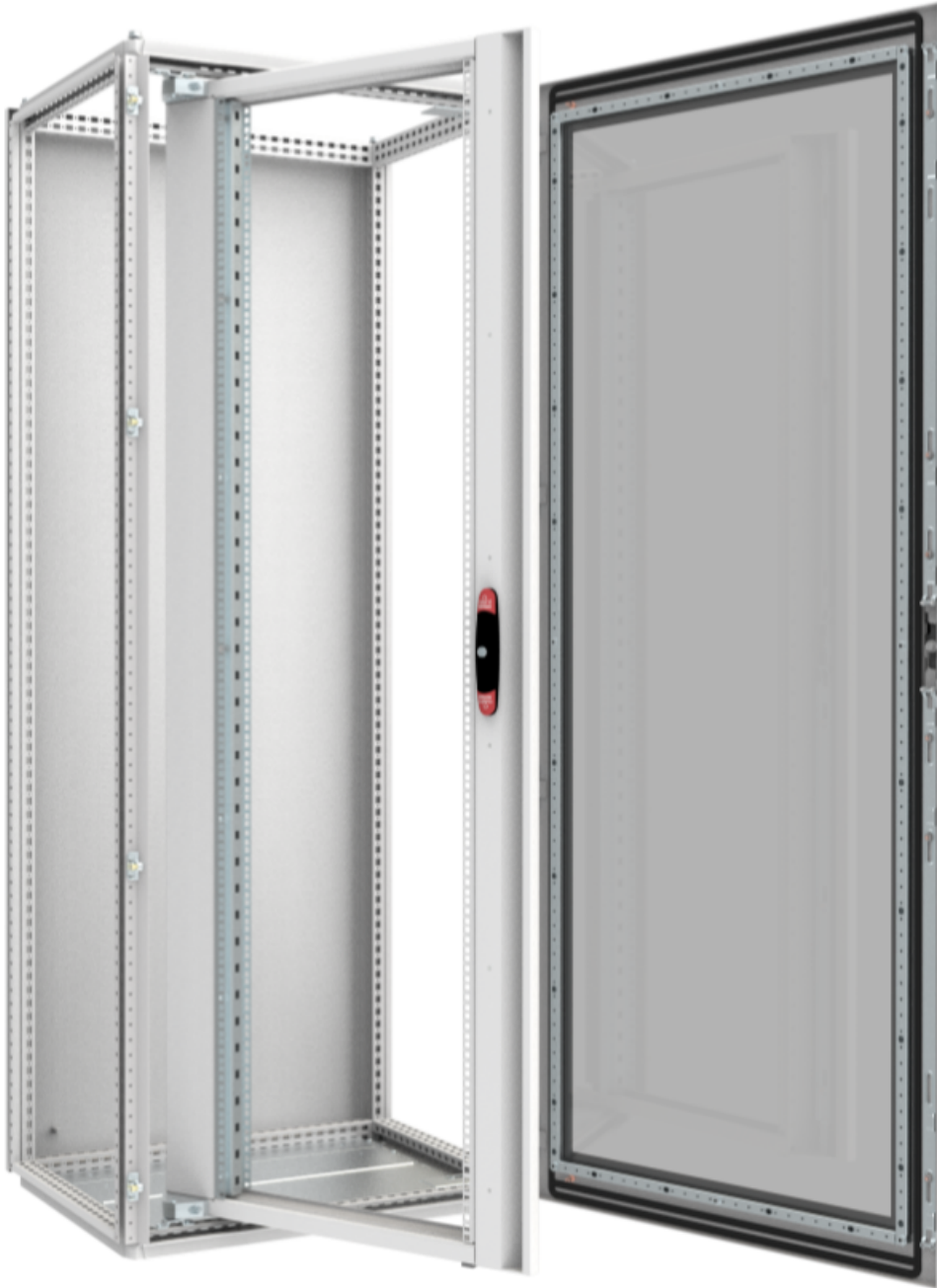

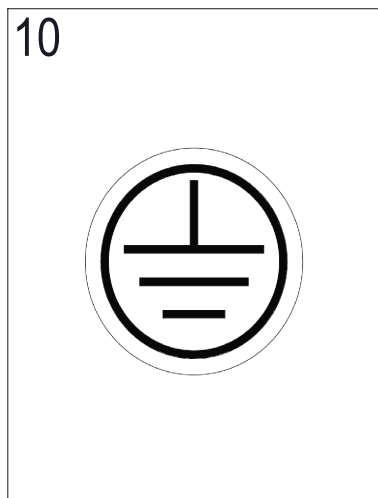
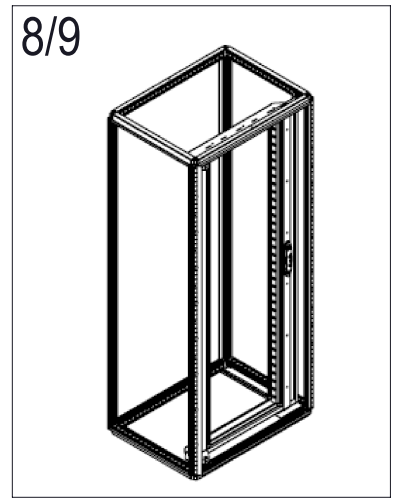
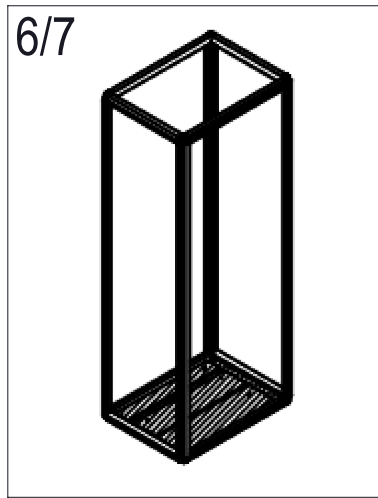
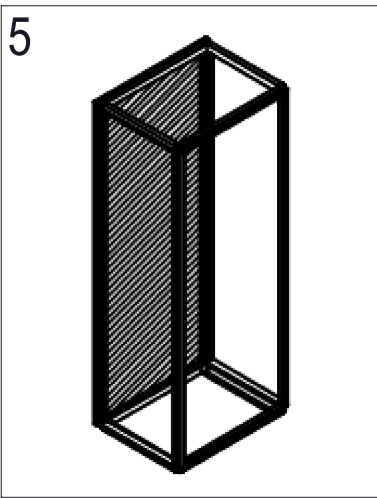
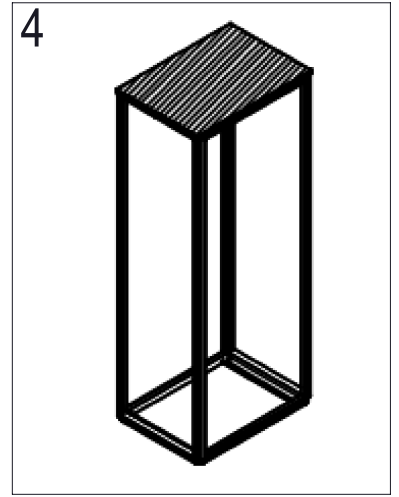
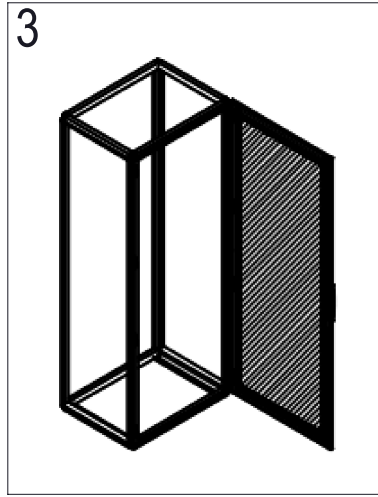
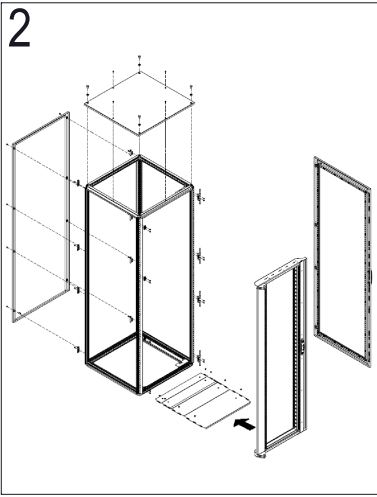



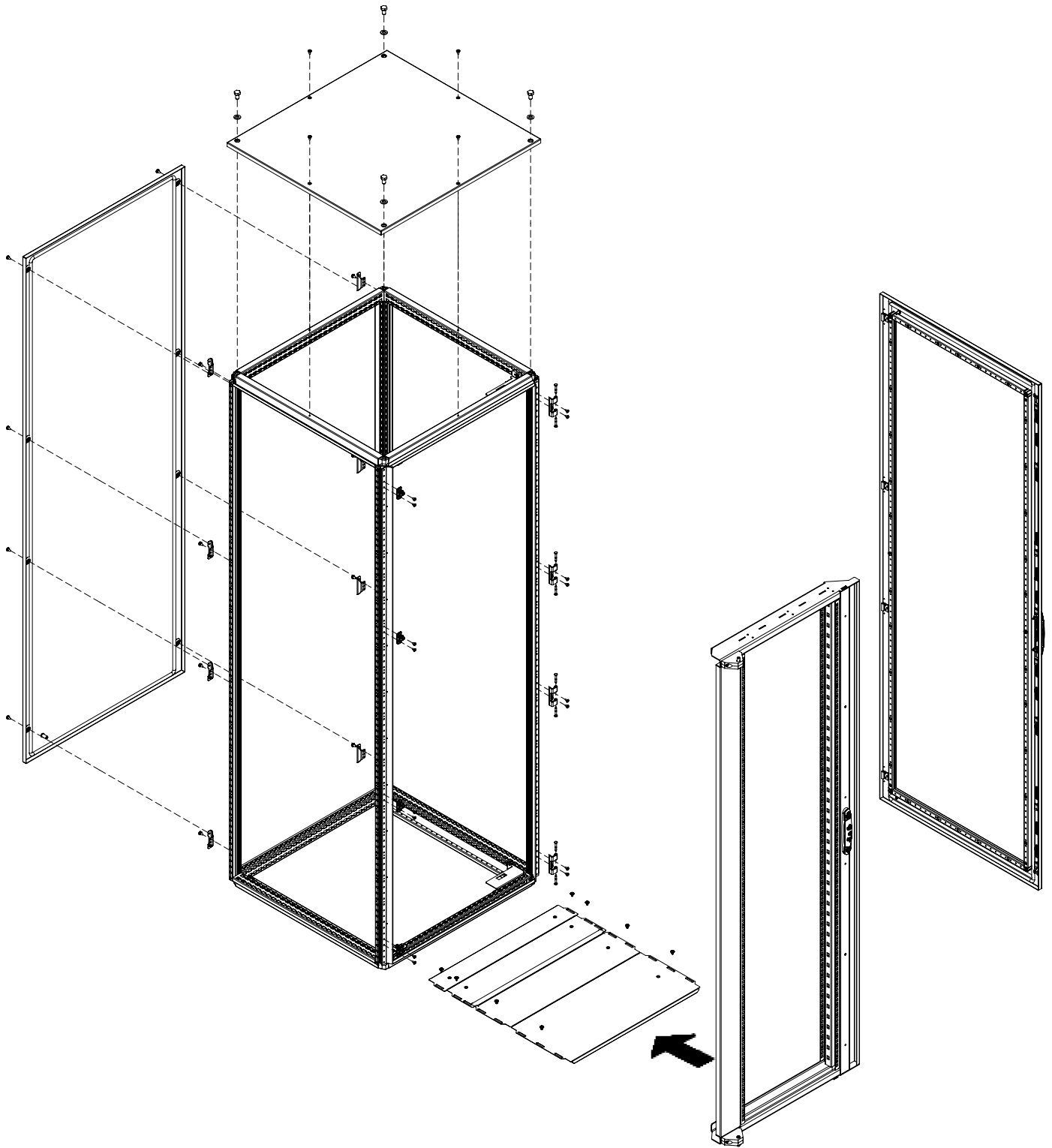

WARNING: When mounting on or over a combustible surface, a floor plate of at least 1.43 mm galvanized or 1.6 mm uncoated steel extended at least 150 mm beyond the equipment on all sides must be installed.

WARNING: In order to maintain the environmental integrity of the enclosure, devices with the same environmental ratings shall be used to close openings in customized enclosure.

MCS DGSFM



GLAZED DOOR

Ref.	Pic.	Qty.
A		4
B		4
C	 M6x12	16

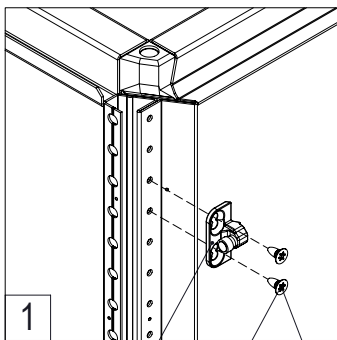
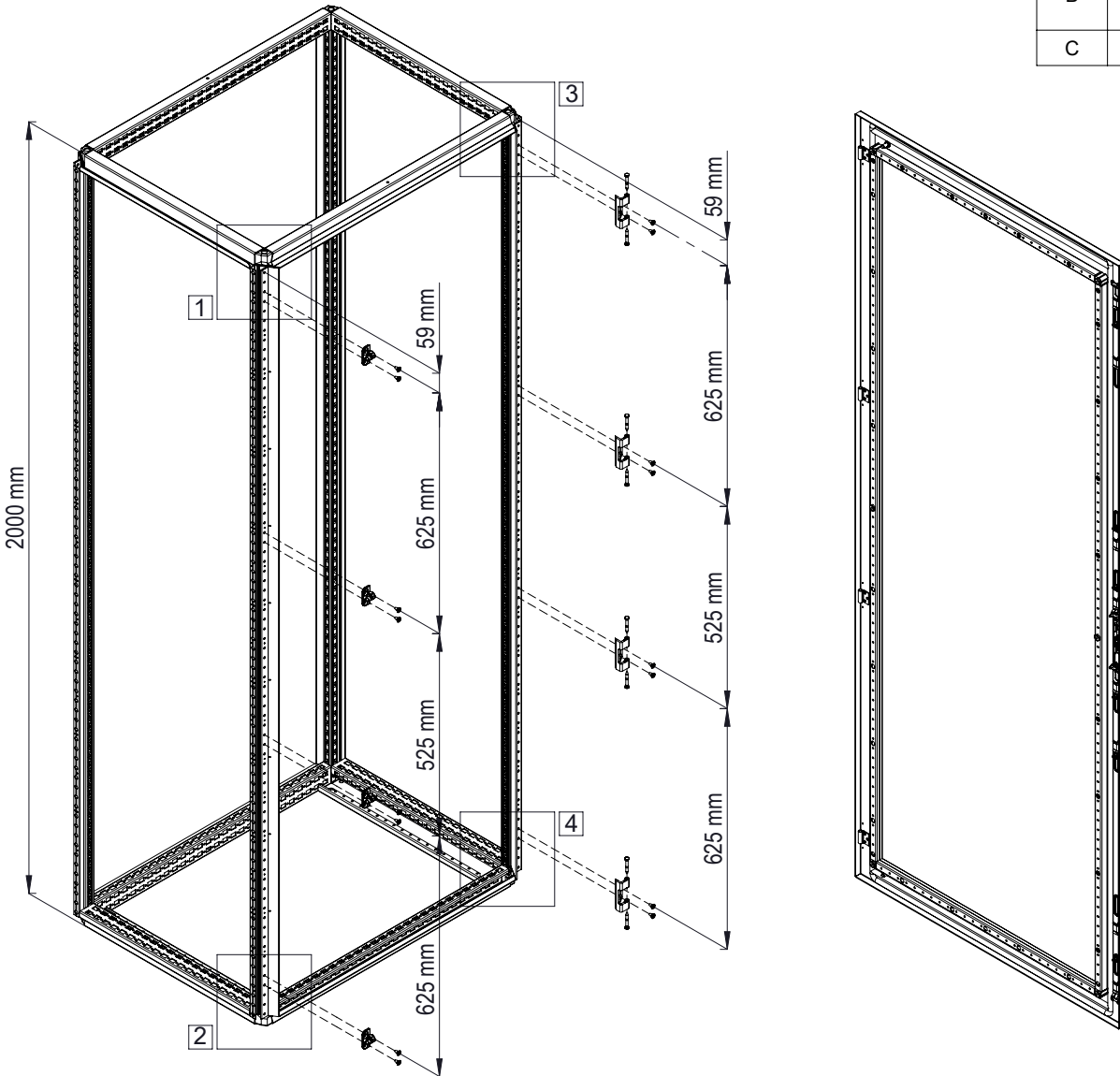

A C Torque 8-9 Nm

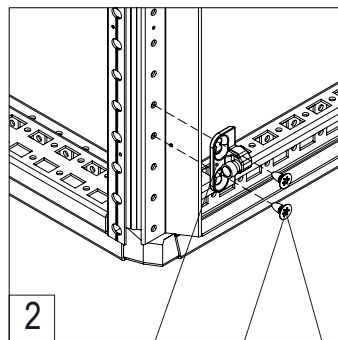

A C Torque 8-9 Nm

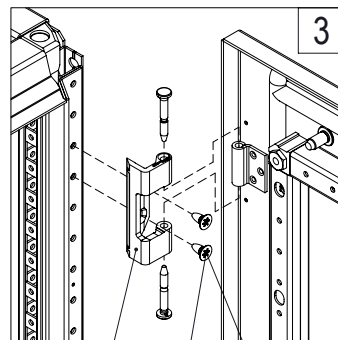

B C Torque 8-9 Nm

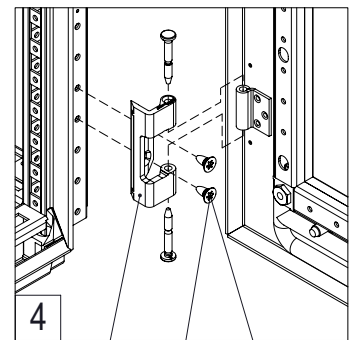

B C Torque 8-9 Nm



ROOF PLATE

Ref.	Pic.	Qty.	
		D=600	D=800
A	M12x20	4	4
B	M12	4	4
C	M6x12	2	4

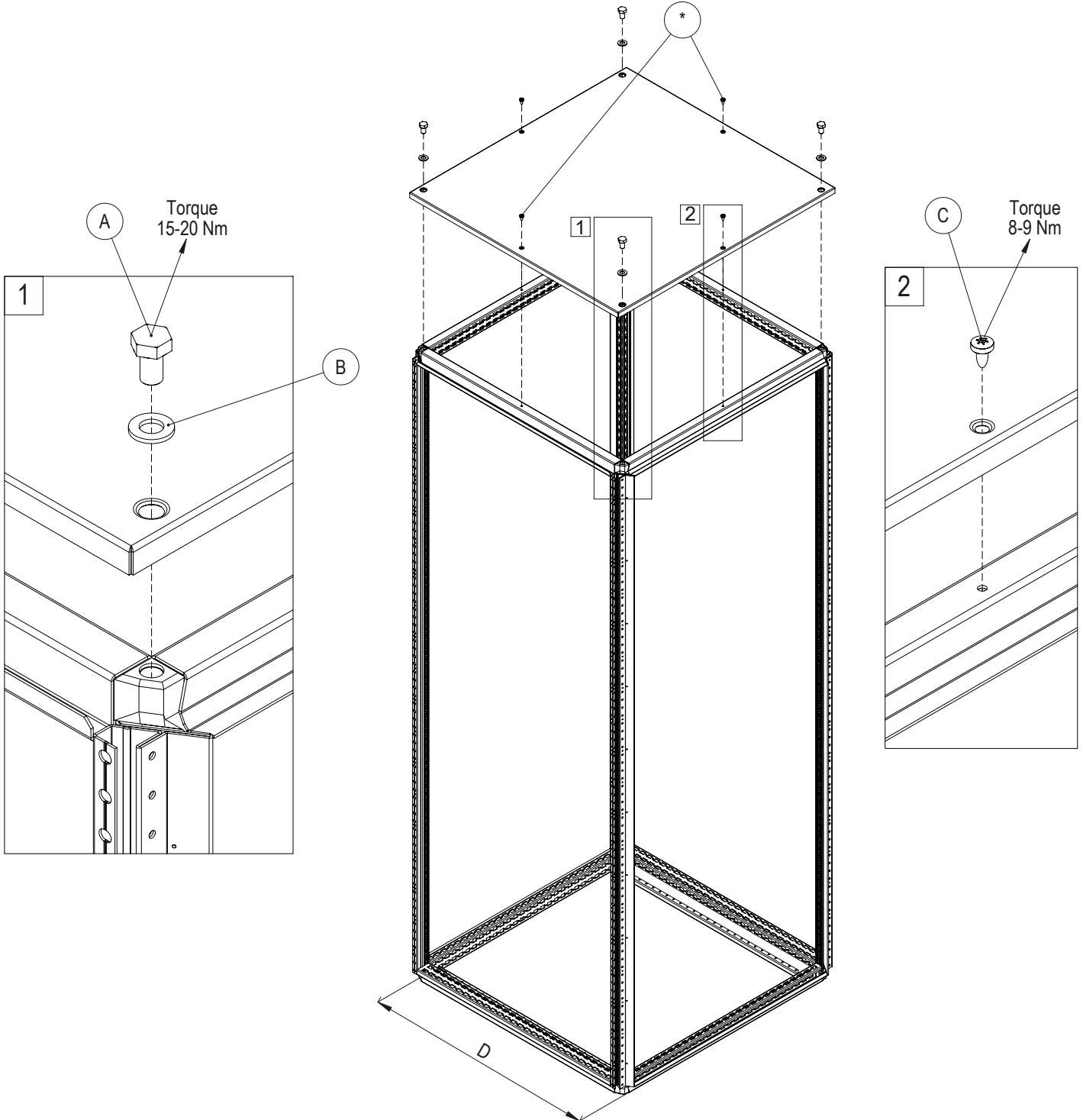

* - Used on enclosures 800 mm deep.

** - Torque value for first tightening. For following tightening, torque value recommended is 4-5 Nm.



BACK PANEL

Ref.	Pic.	Qty.
A		8
B	M6x12	16

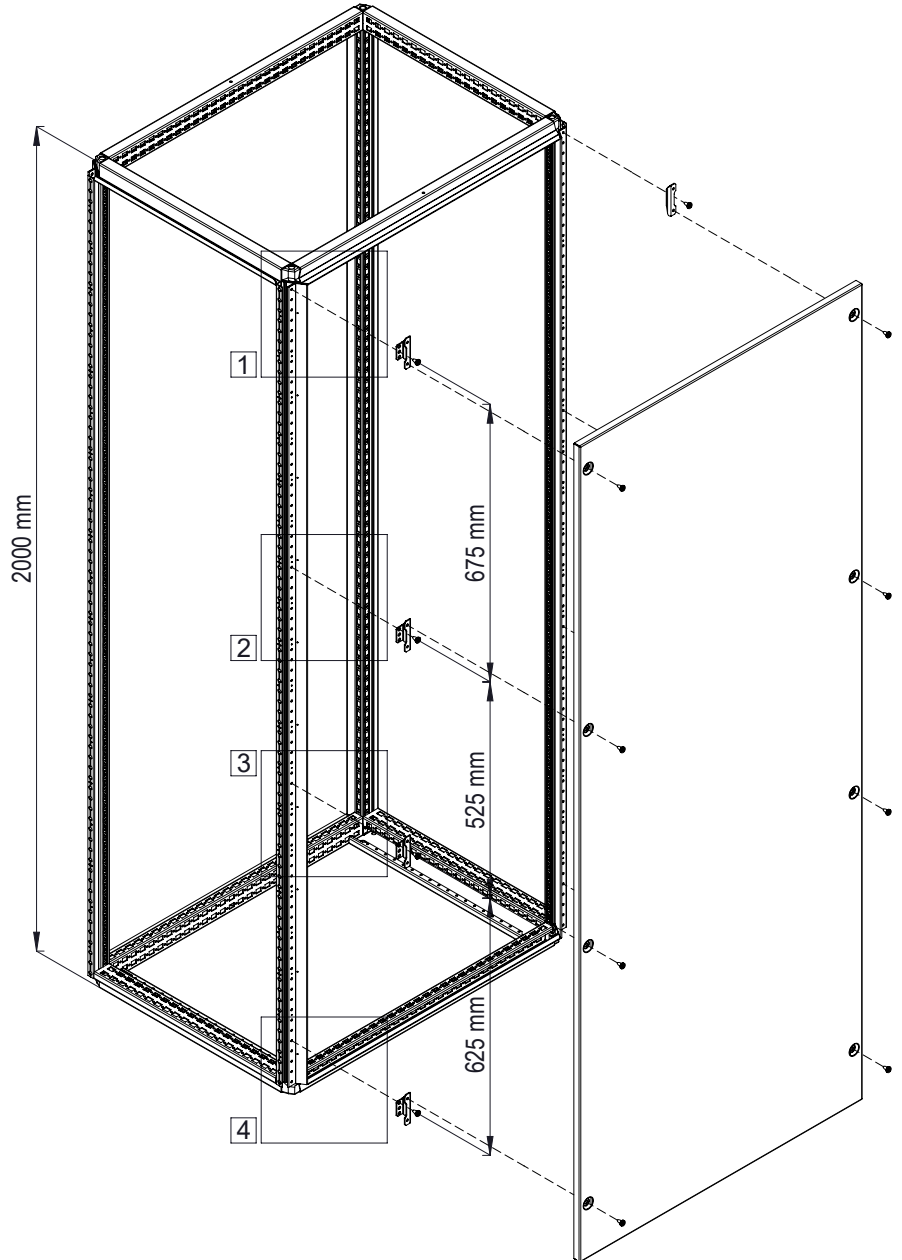
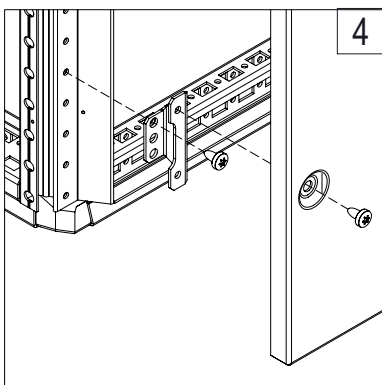
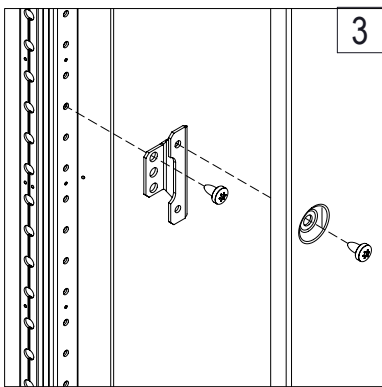
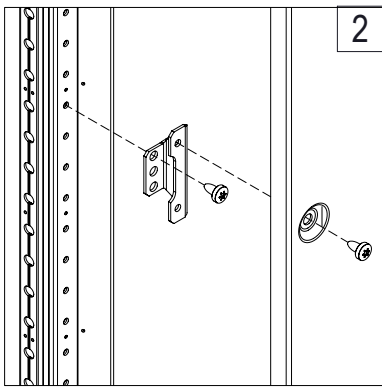
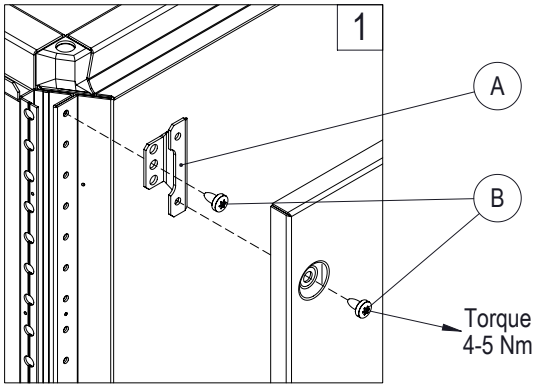



BOTTOM PLATES

Ref.	Pic.	Qty.	
		D=600	D=800
A	St. 5.5x10	6	8
B		5	6

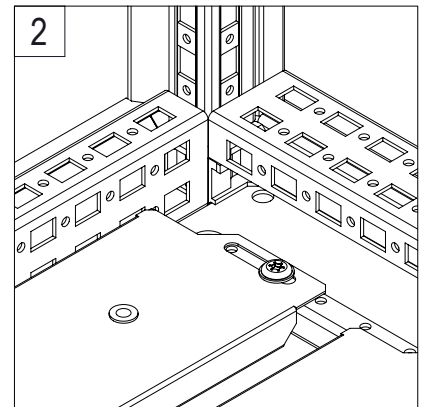
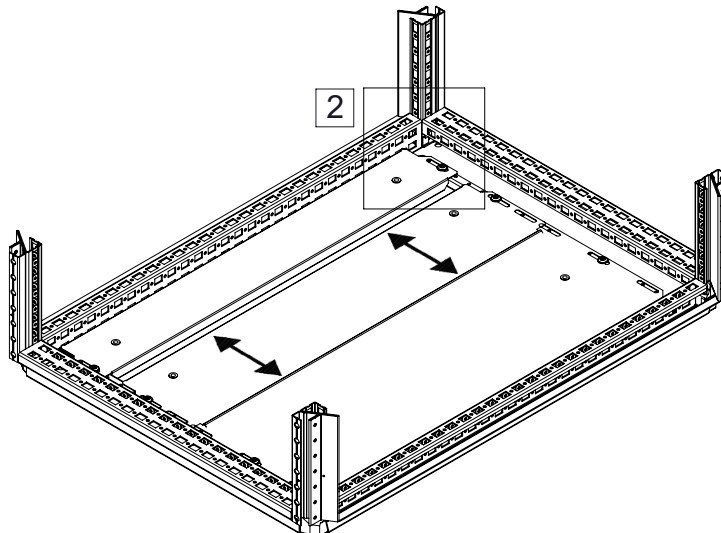
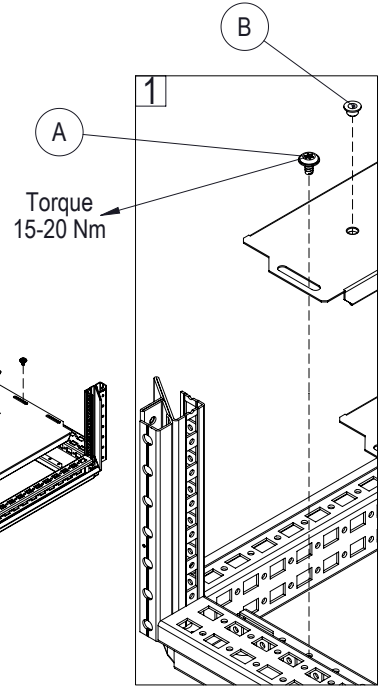
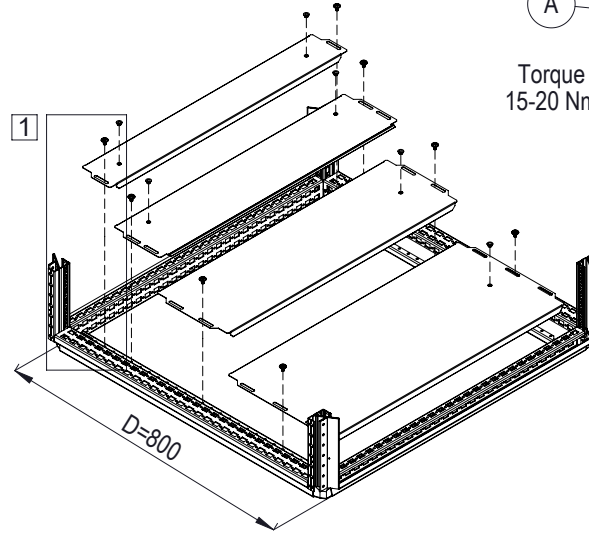
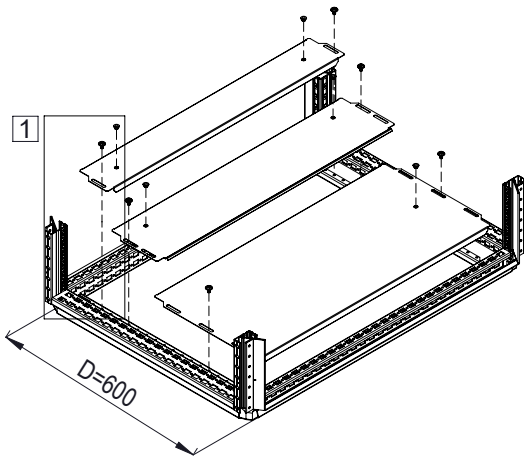



SEALING BOTTOM PLATES *Required for IP55*

Ref.	Pic.	Qty.
A	4,5x8	6 m
B	25x25	1.6 m
C		4

BG01 ordered separately

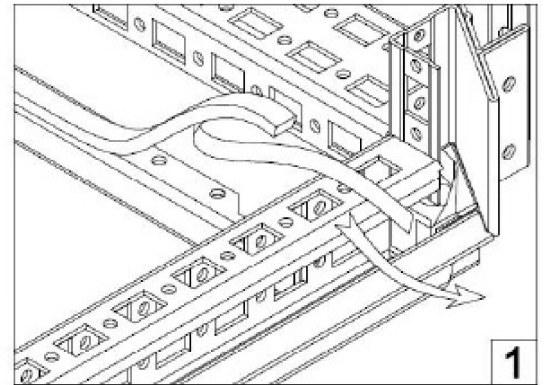
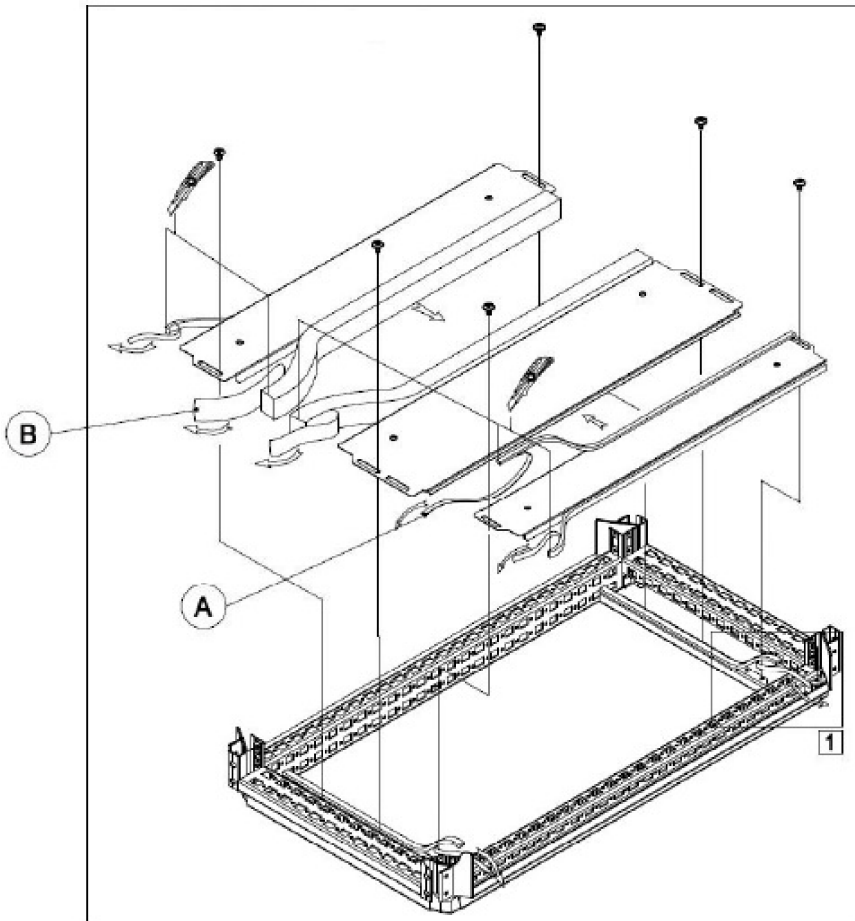

1



SWING FRAME

Ref.	Pic.	Qty.
A		1
B		1
C		1
D		1
E		1
F		2
G		2
H		10

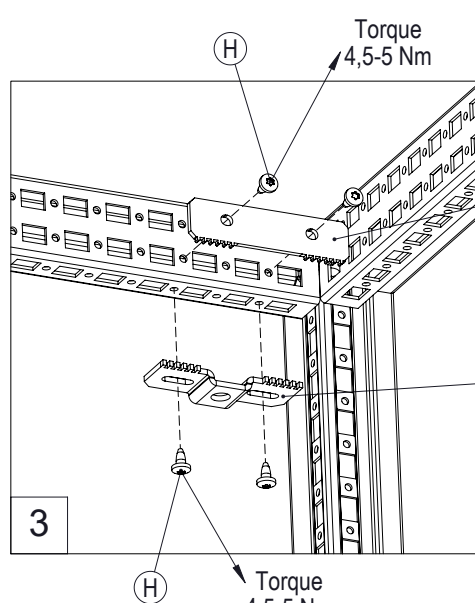
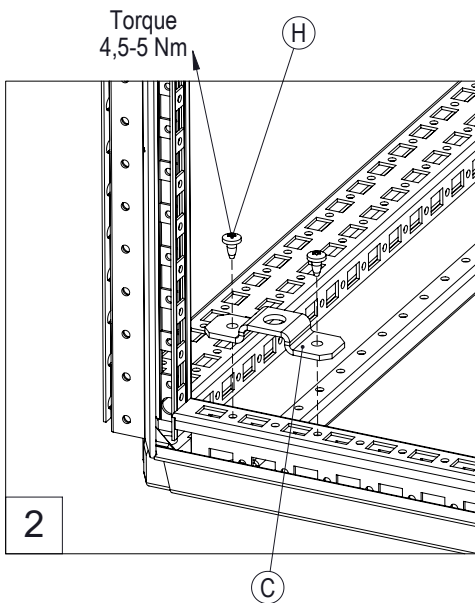
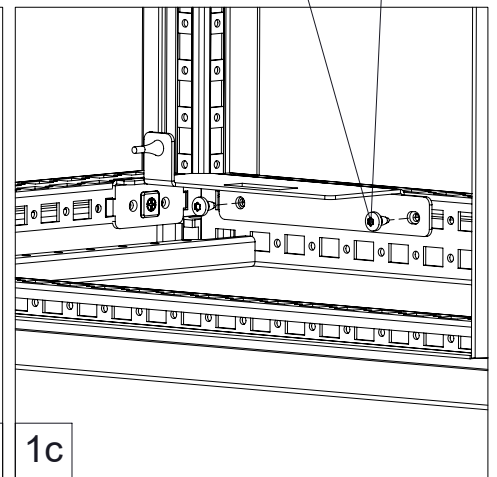
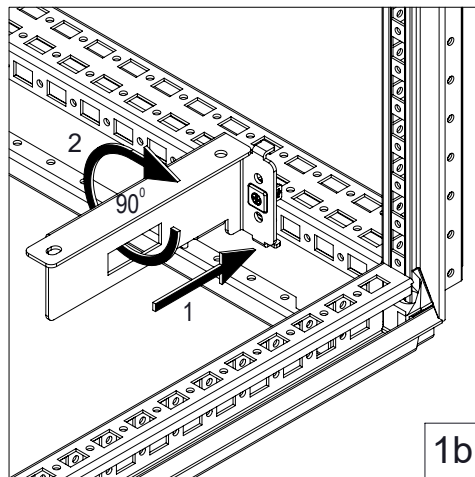
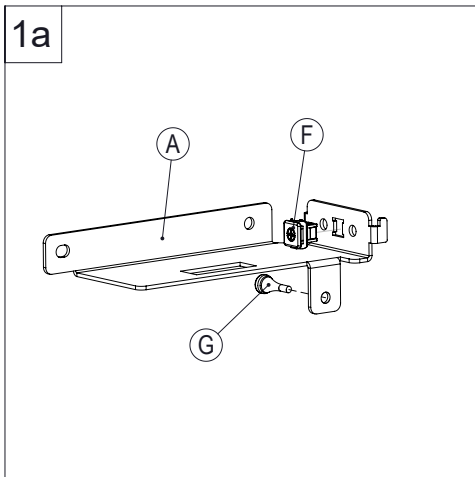
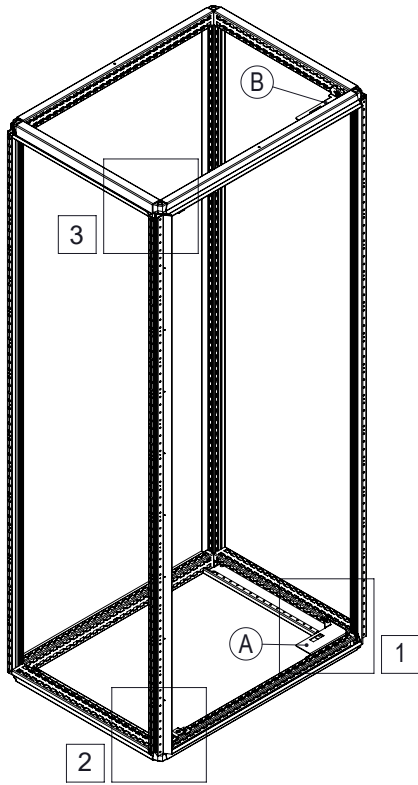

SWING FRAME





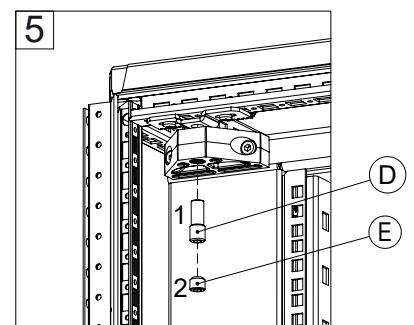
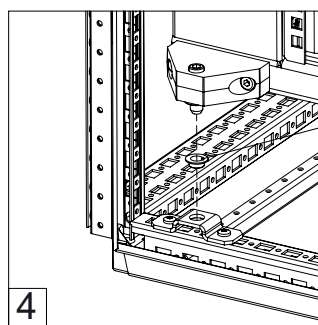
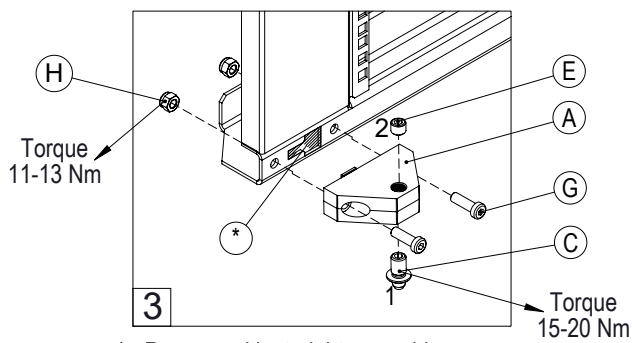
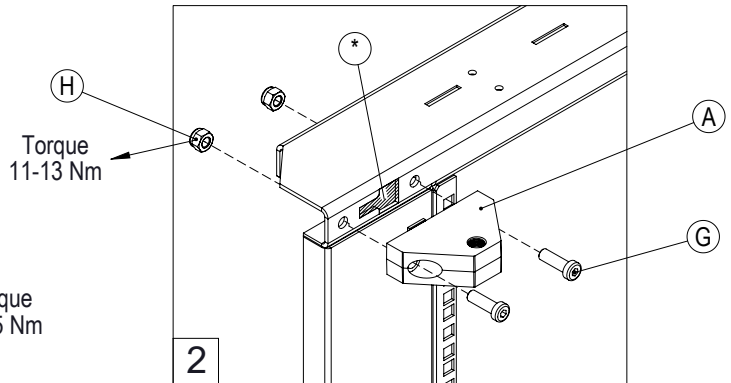
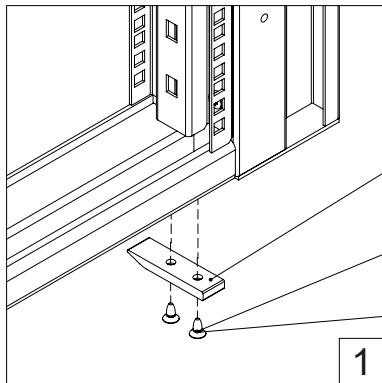
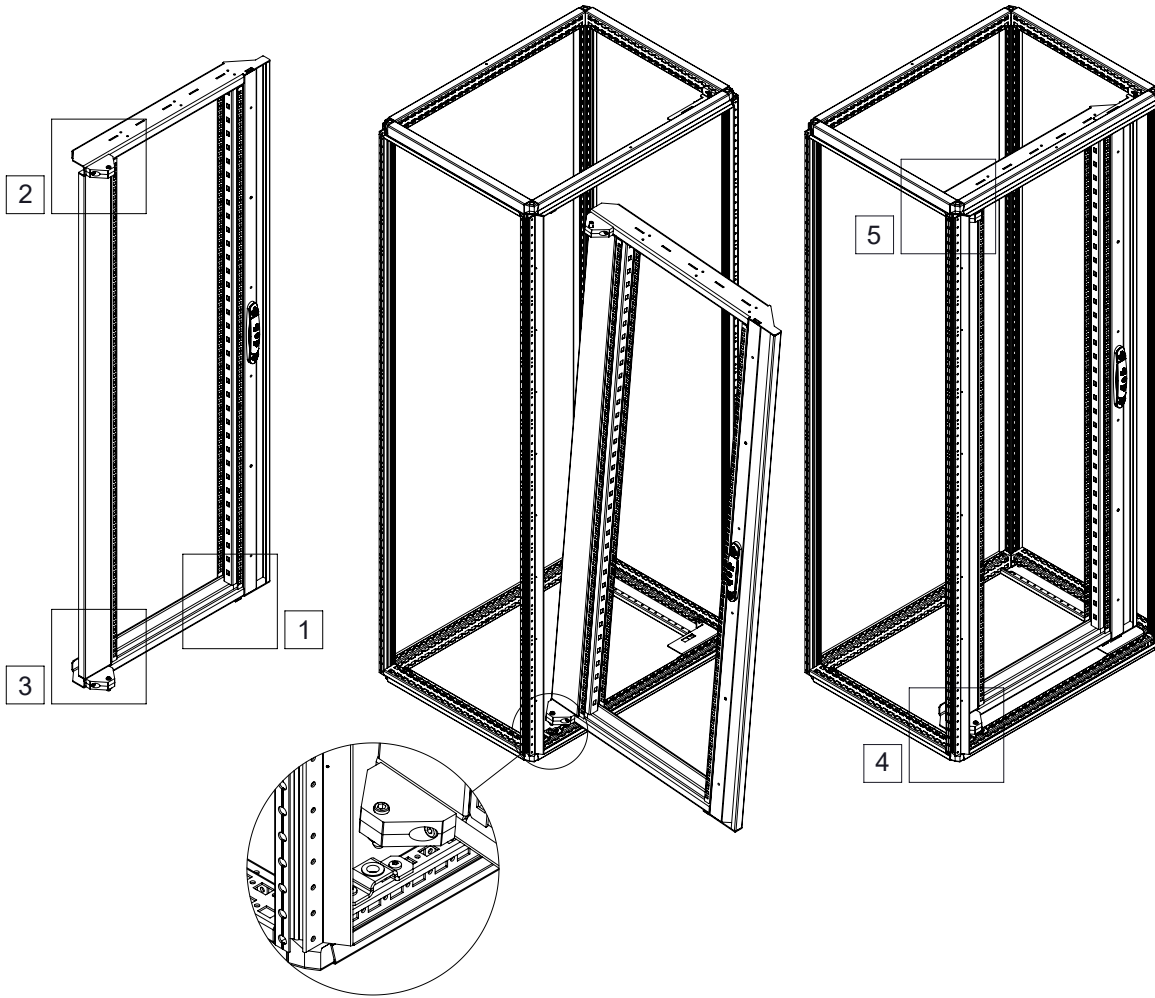



Ref.	Pic.	Qty.
A		2
B		1
C		1
D		1
E		2
F		1
G		4
H		4
I		2



* - Remove with straight screwdriver

EARTHING

Ref.	Pic.	Qty.
A		1
B		1
C		1
D		4
E		2
F		2
G		3

