

OICE

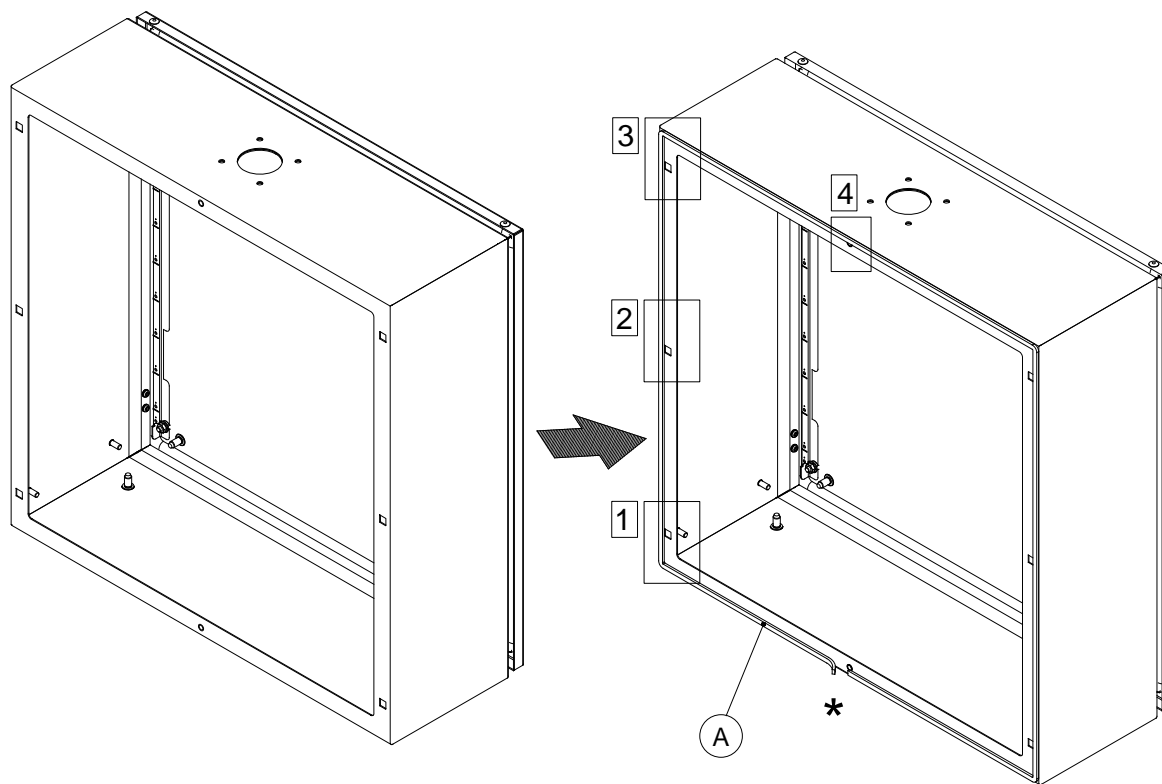

Ref.	Pic.	Qty.
A		1
B		4/6
C		4/6
D		4/6/8
E		2
F		2
G		4
H		2
I		2
J		2

**

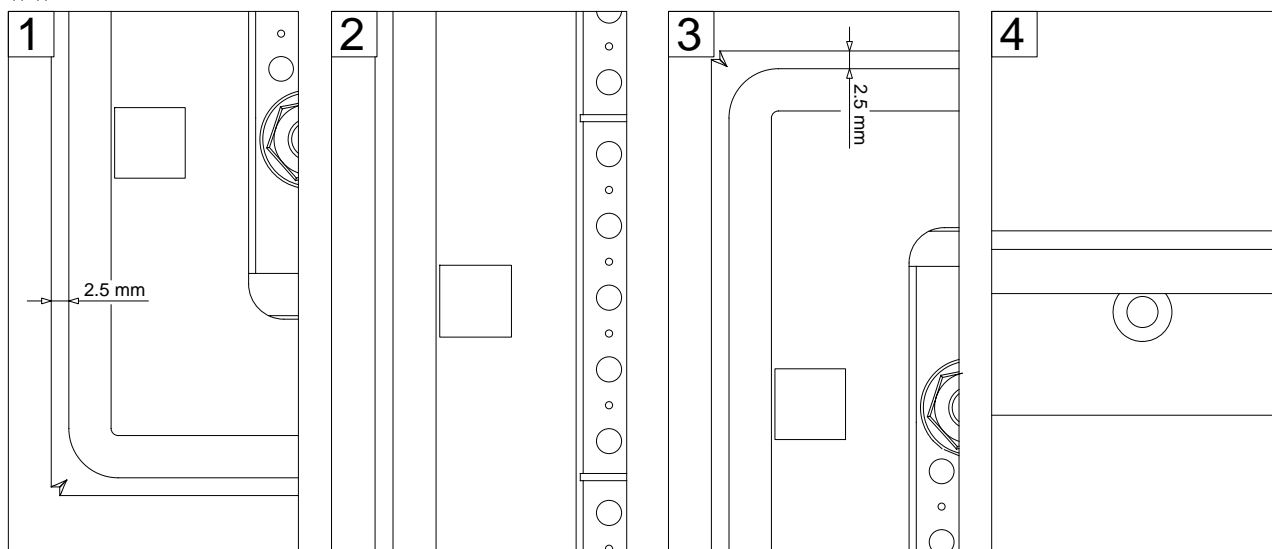

*Start applying the gasket from the indicated zone with the asterisk.

**Do not cover the square holes with the gasket.

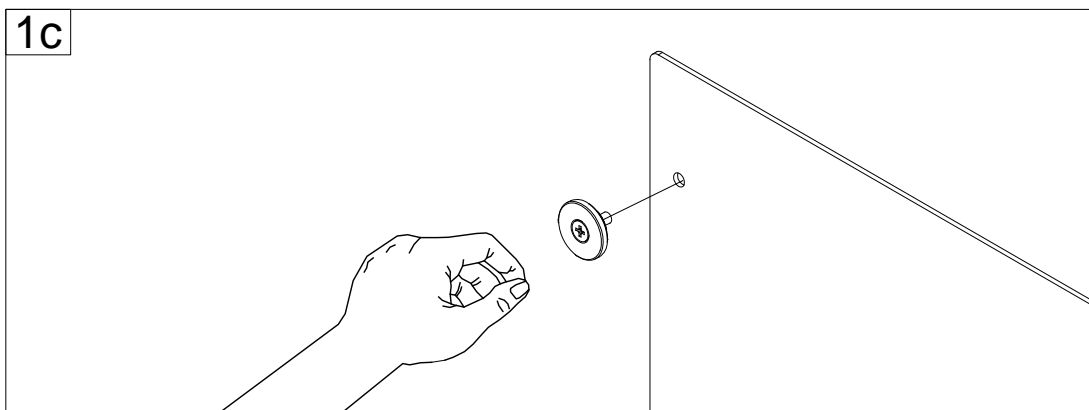
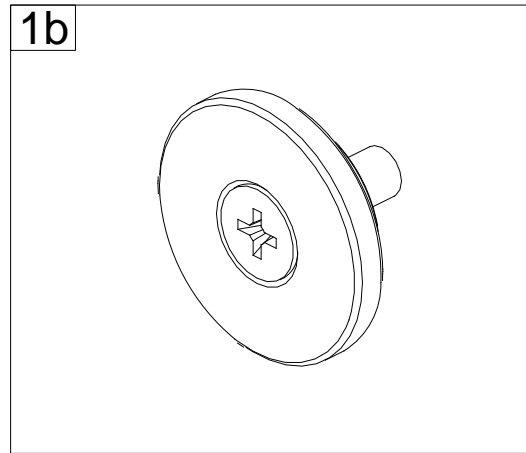
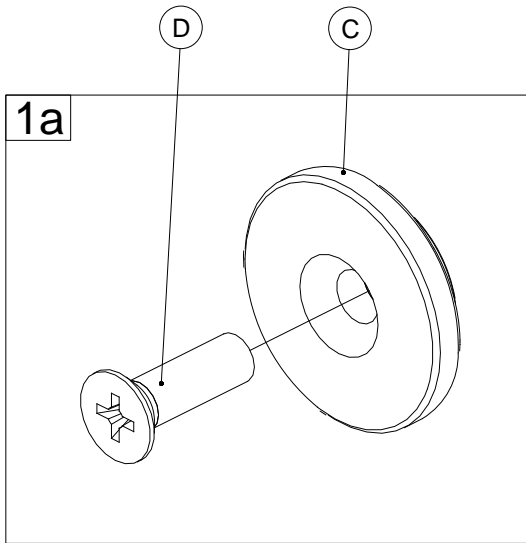
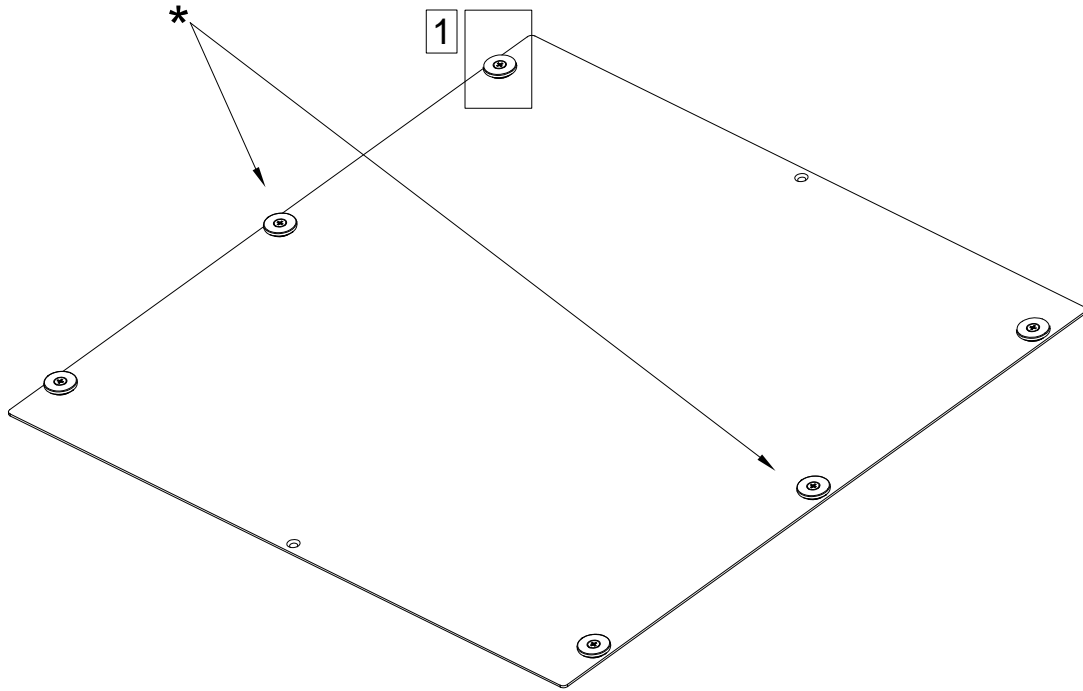

*Only for 500 (H) and above.

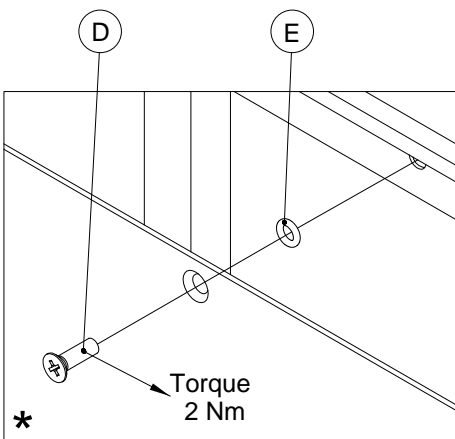
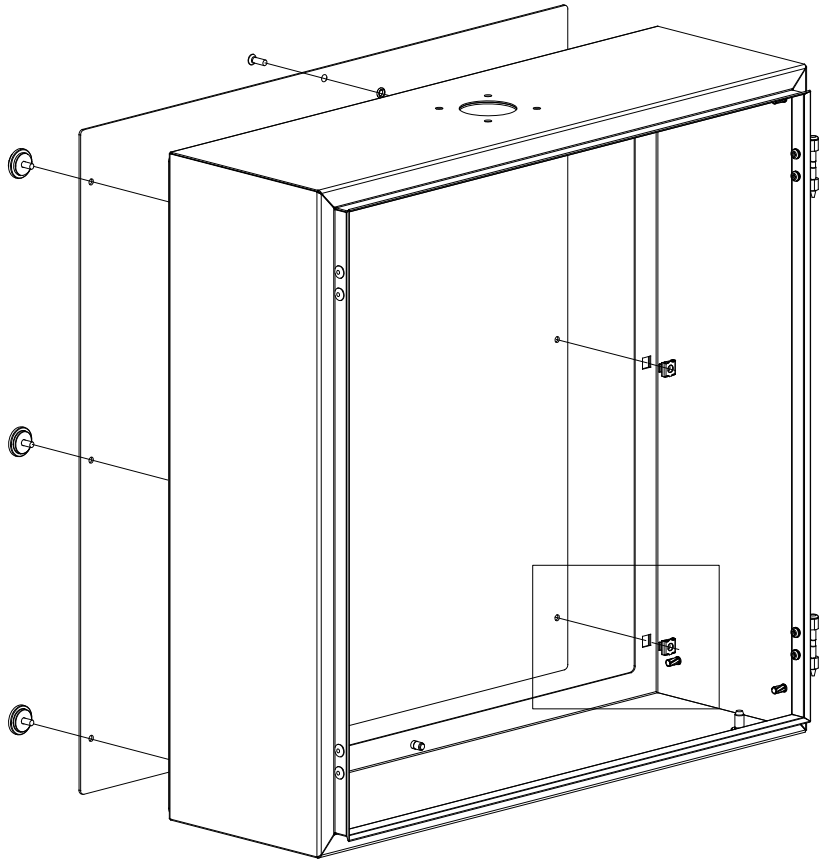
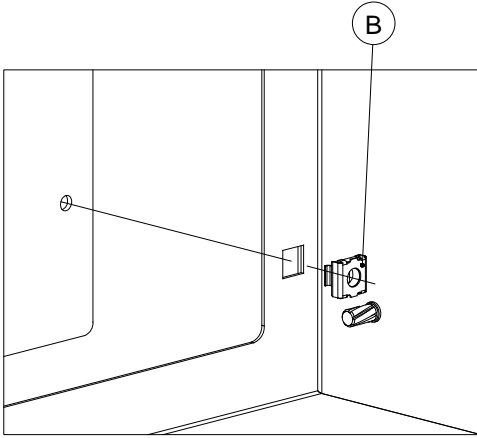

Torque
2 Nm

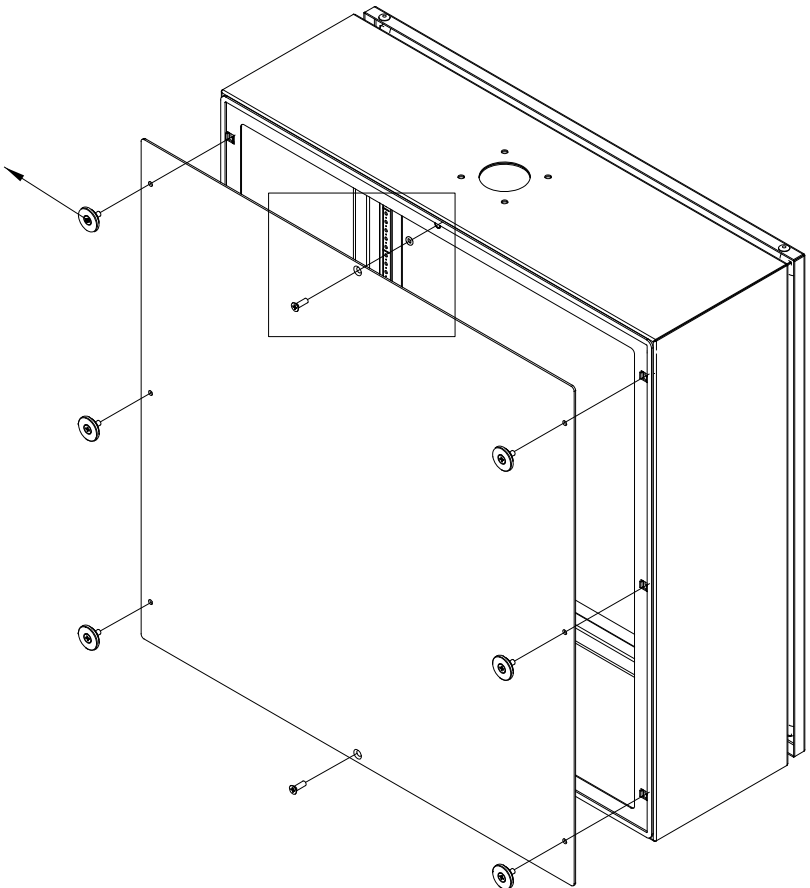

*Only for 400 (W) and above.

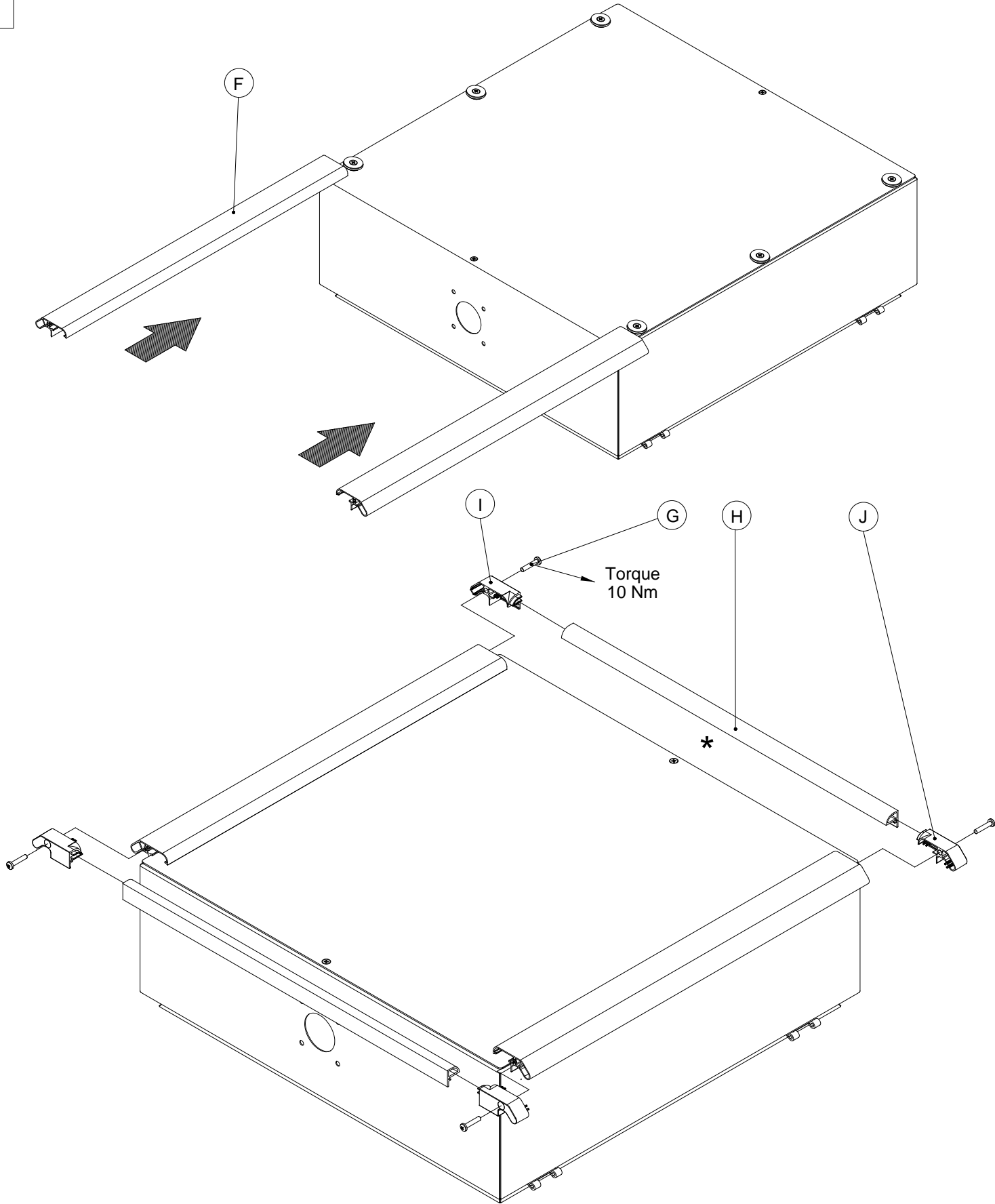

*Mount first the horizontal profile (H) with the caps (I), then fix to the aluminium profiles.

BMP / BPP-BDR



*Accessories available BMP

Ref.	Pic.	Qty.
A		4/6

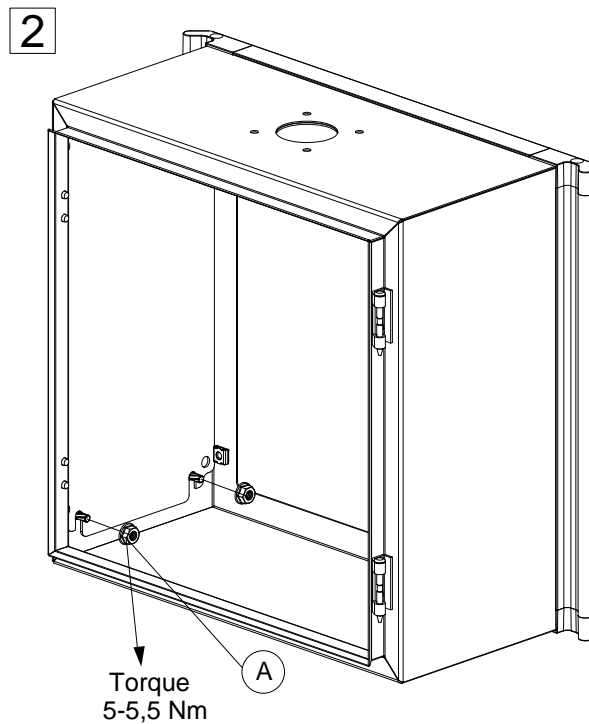
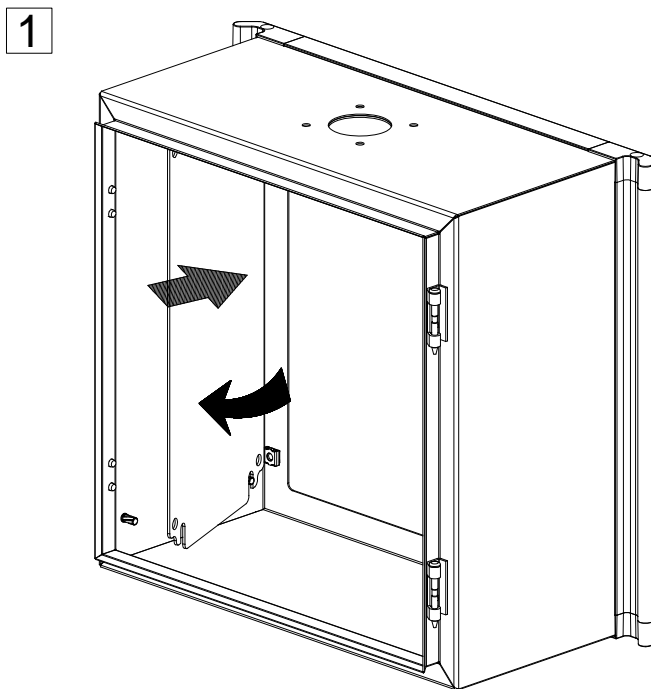

*Accessories available BPP - BDR

Ref.	Pic.	Qty.
A		4/6
B	ST4,8x9,5 	2

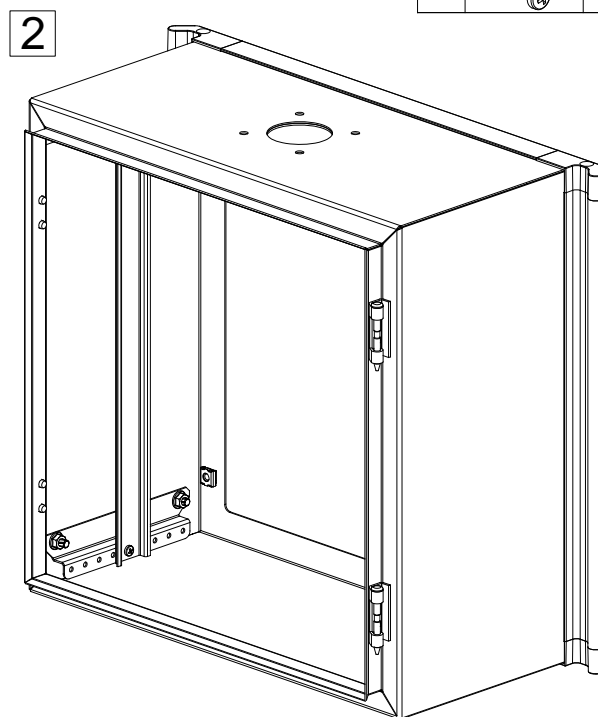
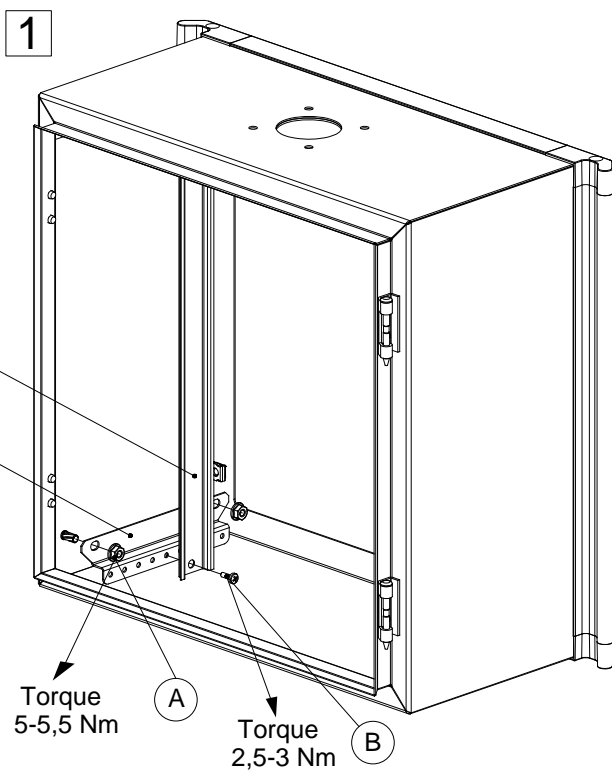

BMP



Ref.	Pic.	Qty.
A		4

*Accessories available

