

E-100-CLE

High-Profile Lighted End Seal Installation Instructions

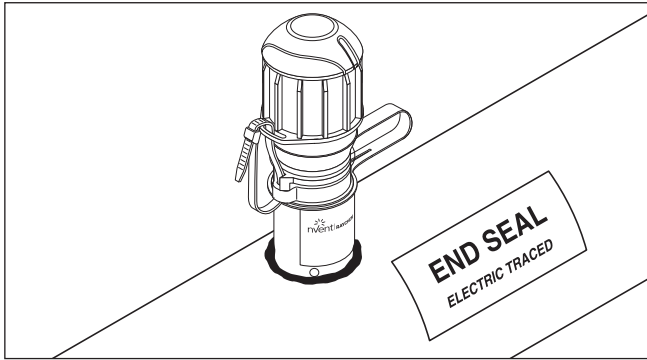

DESCRIPTION

The nVent RAYCHEM E-100-CLE is a Type 4X-rated end seal kit with a light that indicates voltage at the end of the circuit. It is designed for use with nVent RAYCHEM XL-Trace Edge heating cables. Once installed, the end seal is easily re-entered for maintenance and the heating cable can be accessed without removing the end seal. The LED indicator light provides excellent visibility.

These kits may be installed at temperatures as low as 0°F (-18°C), and the maximum ambient temperature of 104°F (40°C). For easier installation store above freezing until just before installation.

Kit is rated for 100 to 277 V.

Make sure voltage rating of light is the same as that of the heat-tracing circuit.

For technical support call nVent at (800) 545-6258.

APPROVALS



For 3, 5 and 8 XL-Trace Edge cables only

KIT CONTENTS

Item	Qty	Description
A	1	End seal stand and light assembly
B	2	Insulated parallel crimps
C	1	End seal label
D	1	Cable lubricant
E	1	Cable tie
F	1	Core sealer

TOOLS REQUIRED

- Wire cutters
- Utility knife
- Needle nose pliers
- Slotted screwdriver or nutdriver
- Panduit CT-100 crimp tool or equivalent

ADDITIONAL MATERIALS REQUIRED

- Pipe strap
- nVent RAYCHEM GT-66 or GS-54 glass cloth tape

OPTIONAL MATERIALS

- Small pipe adapter for 1 in (25 mm) and smaller pipes:
Catalog number JBS-SPA P/N E90515-000

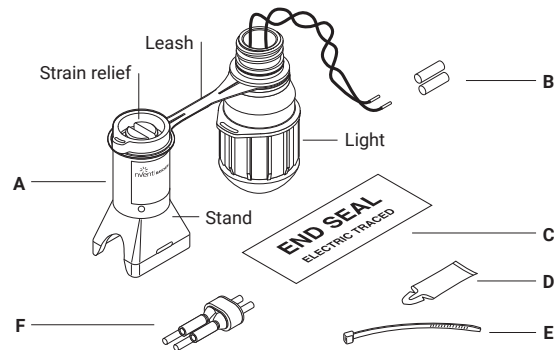

WARNING:

This component is an electrical device that must be installed correctly to ensure proper operation and to prevent shock or fire. Read these important warnings and carefully follow all of the installation instructions.

- To minimize the danger of fire from sustained electrical arcing if the heating cable is damaged or improperly installed, and to comply with the requirements of nVent, agency certifications, and national electrical codes, ground-fault equipment protection must be used. Arcing may not be stopped by conventional circuit breakers.
- Component approvals and performance are based on the use of nVent-specified parts only. Do not use substitute parts or vinyl electrical tape.

- The black heating cable core and fibers are conductive and can short. They must be properly insulated and kept dry.
- Damaged bus wires can overheat or short. Do not break bus wire strands when scoring the jacket or core.
- Keep components and heating cable ends dry before and during installation.
- Bus wires will short if they contact each other. Keep bus wires separated.
- Use only fire-resistant insulation materials, such as fiberglass wrap or flame-retardant foam.
- Leave these installation instructions with the user for future use.

AVERTISSEMENT :

Ce composant électrique doit être installé correctement pour éviter les risques d'incendie ou de chocs électriques. Lire ces avertissements importants et suivre attentivement toutes les instructions d'installation.

- Pour réduire le danger d'incendie causé par un arc électrique entretenu, si le câble chauffant est endommagé ou mal installé, et pour respecter les exigences de nVent et celles des codes applicables, il est impératif d'utiliser une protection par disjoncteur différentiel. Les disjoncteurs ordinaires ne sont pas toujours capables de supprimer les arcs électriques.
- Les approbations et les performances des composants sont basées sur l'utilisation des pièces nVent spécifiées seulement. N'utilisez pas de pièces de rechange ou de ruban isolant en vinyle.

- Le noyau et les fibres du câble chauffant noir sont conducteurs et peuvent provoquer un court-circuit. Ils doivent être correctement isolés et gardés à sec.
- Les fils omnibus endommagés peuvent surchauffer ou subir un court-circuit.
- Ne brisez jamais les fils omnibus lorsque vous incisez la gaine ou le noyau.
- Maintenez les composants et les extrémités des câbles chauffants secs avant et pendant l'installation.
- Les fils omnibus peuvent provoquer un court-circuit s'ils se touchent. Les garder à l'écart les uns des autres.
- N'utilisez que des matériaux isolants ininflammables, par exemple une gaine de fibre de verre ou de la mousse ignifuge.
- Laissez ces instructions d'installation à l'utilisateur pour qu'il puisse les consulter.

CAUTION:

HEALTH HAZARD: Prolonged or repeated contact with the sealant in the core sealer may cause skin irritation. Wash hands thoroughly. Overheating or burning the sealant will produce fumes that may cause polymer fume fever. Avoid contamination of cigarettes or tobacco. Consult VEN 0033 for further information.

CHEMTREC 24-hour emergency telephone: (800) 424-9300.

Non-emergency health and safety information: (800) 545-6258.

MISE EN GARDE :

DANGER POUR LA SANTÉ : Le contact prolongé ou répété avec le produit d'étanchéité du noyau peut provoquer une irritation de la peau. Lavez-vous les mains soigneusement. La surchauffe et la combustion du produit d'étanchéité produira des vapeurs qui peuvent causer la fièvre des vapeurs de polymères. Évitez la contamination des cigarettes ou du tabac. Consultez la fiche technique santé-sécurité (FTSS) VEN 0033 pour obtenir de plus amples informations.

Téléphone en cas d'urgence 24 heures sur 24 de CHEMTREC : (800) 424-9300

Renseignements non urgents en matière de santé et de sécurité : (800) 545-6258

Heating Cable Types

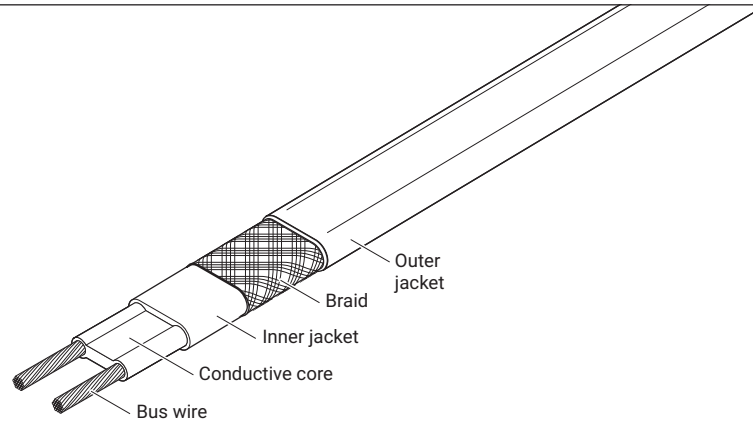

3, 5, 8 XL-Trace Edge

1

- Allow approximately 24 in (60 cm) of heating cable for installation.
- Cut off heating cable end at about 45° for easier insertion.
- Apply lubricant for easier insertion into stand.

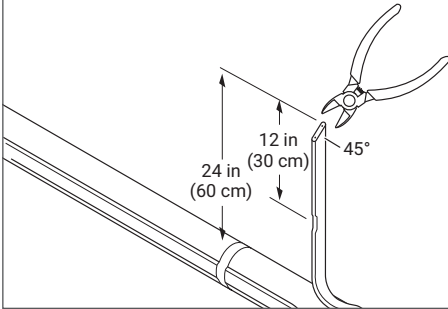

2

- Optional: If stand is to be installed on bottom side of pipe, knock out drain hole prior to inserting cable.
- Slide heating cable through stand.
- Square off cable end with 90° cut.

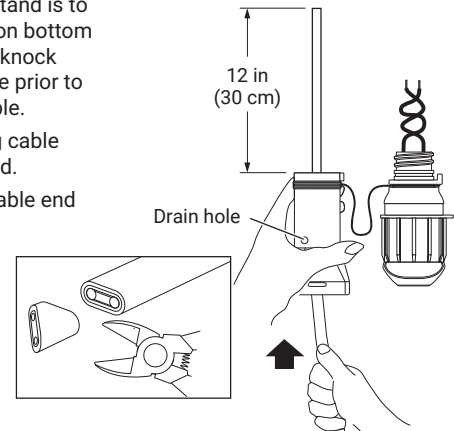

3

- Measure exactly 2¼ in (57 mm).
- Lightly score outer jacket around and down as shown.
- Bend heating cable to break jacket at score; peel off jacket.
- Remove all exposed braid.

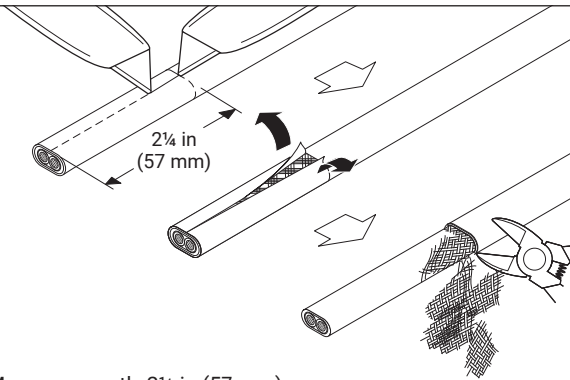

4

Do not cut bus wires

- Measure exactly 1 3/8 in (35 mm).

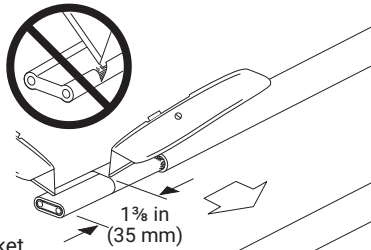

- Lightly score inner jacket around and down as shown.

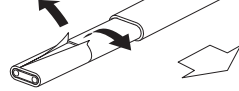

- Peel off jacket.

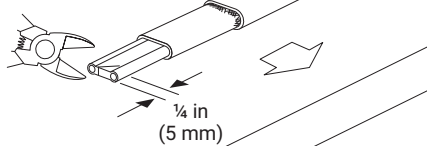

- Notch core.

- Peel bus wire from core.

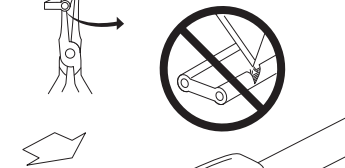

- Score core between bus wires at inner jacket.

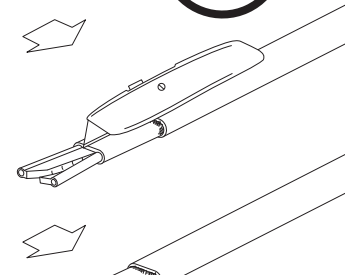

- Bend and snap core.

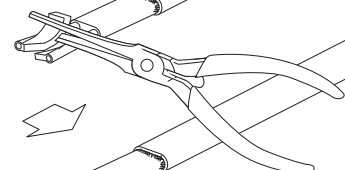

- Peel core from bus wire.
- Remove any remaining core material from bus wires.



5

- Mark the jacket as shown.

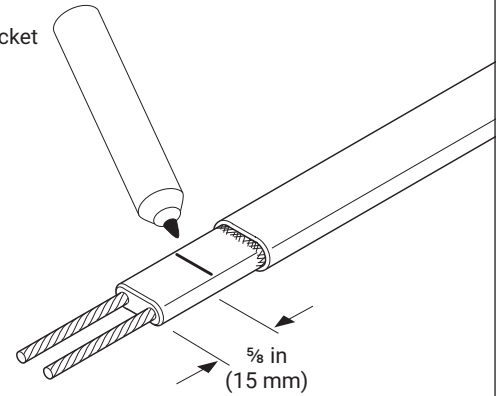

6

⚠ CAUTION: Health Hazard. Wash hands after contact with sealant. Consult safety data sheet VEN 0033.

⚠ AVERTISSEMENT : risque pour la santé. Se laver les mains après tout contact avec le produit d'étanchéité. Consulter la fiche de données de sécurité VEN 0033.

- If needed, re-twist and straighten bus wires, then insert bus wires into guide tubes as shown.

Make sure all strands go into the tubes.

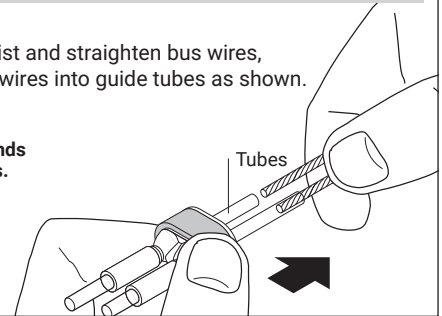

7

- Push core sealer onto the heating cable to the mark made in step 5.

Note: Extra force may be required for larger cables or at lower temperatures.

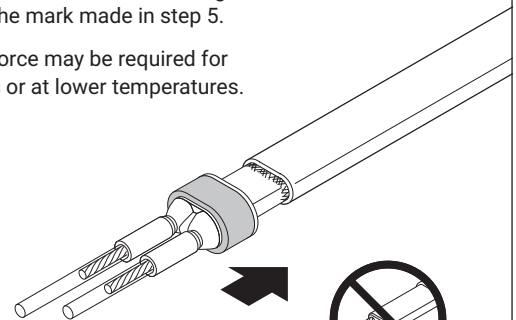

Make sure the bus wires do not kink, bunch, or crossover.

8

- Remove the guide tubes and dispose of them in a plastic bag.

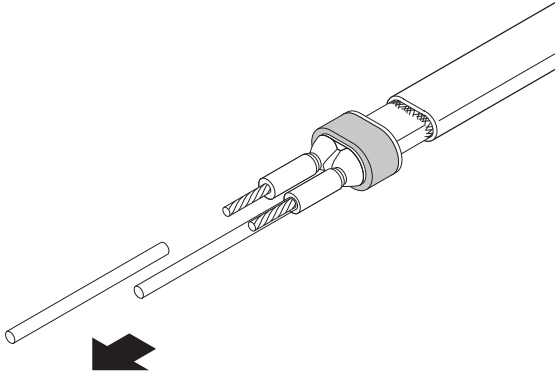

9

- Pull cable back through end seal stand until braid is just visible above strain relief.

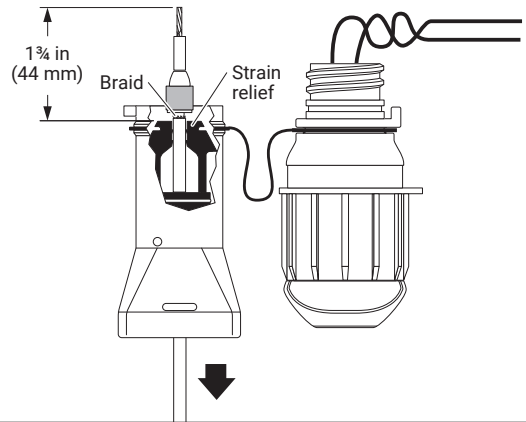

10

- Trim exposed conductors.

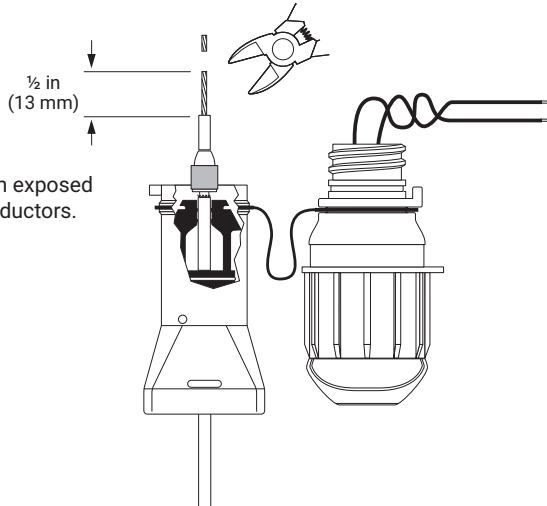

11

- Fasten end seal stand to pipe with pipe strap. Do not pinch heating cable. Be sure pipe strap is under heating cable.
- Loop and tape extra heating cable to pipe. Minimum bend radius is $\frac{3}{4}$ in (20 mm).

CAUTION: To avoid pinching the heating cable, be sure the cable is not under the pipe strap.

AVERTISSEMENT : Pour éviter de pincer le câble chauffant, assurez-vous que le câble ne se trouve pas sous la sangle du tuyau.

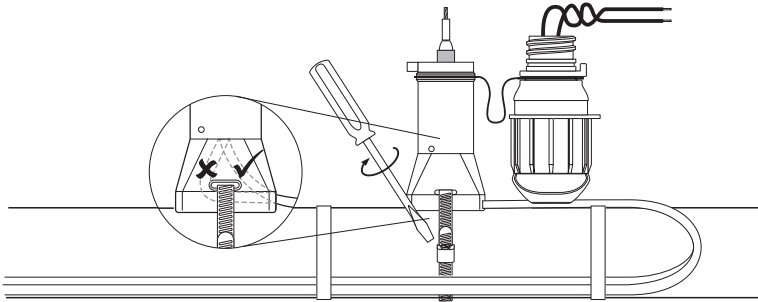

11A

Note: For 1-in (25-mm) and smaller pipes use adapter (purchased separately) between stand and pipe.

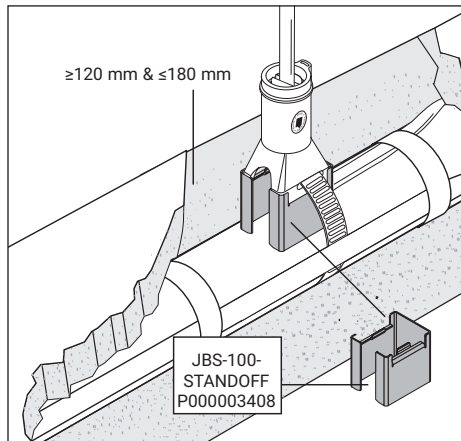
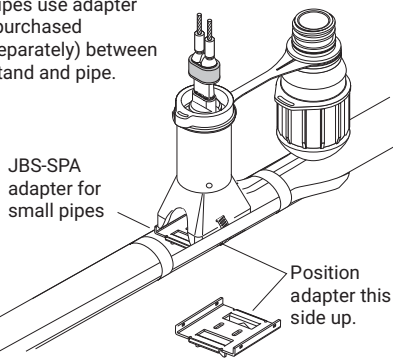

12

- Place blue crimps onto bus wires.

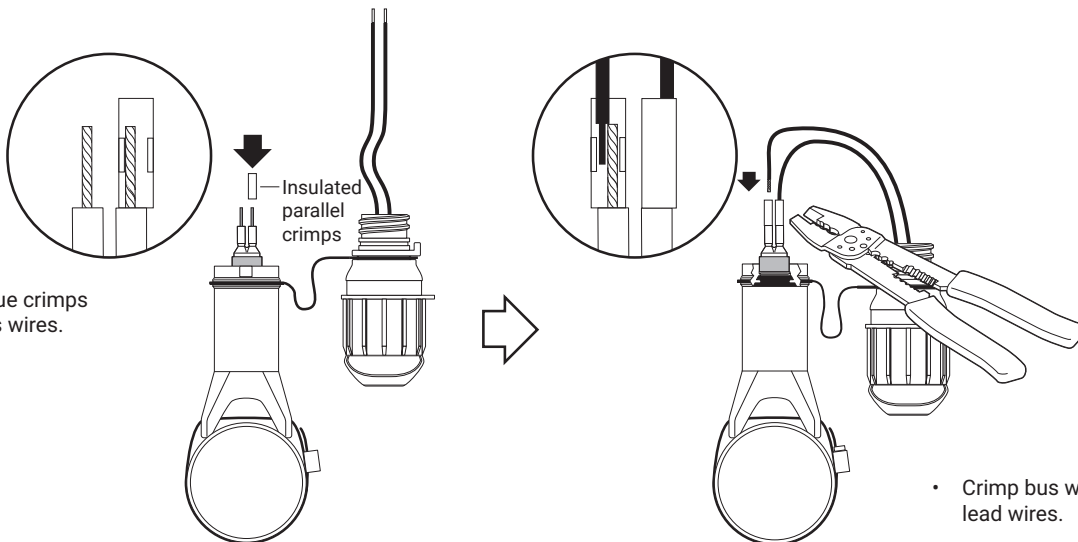

- Crimp bus wires to lead wires.

13

- Push excess wire inside light.

- Tighten light onto end seal stand. Torque = 22 +/- 2 Nm

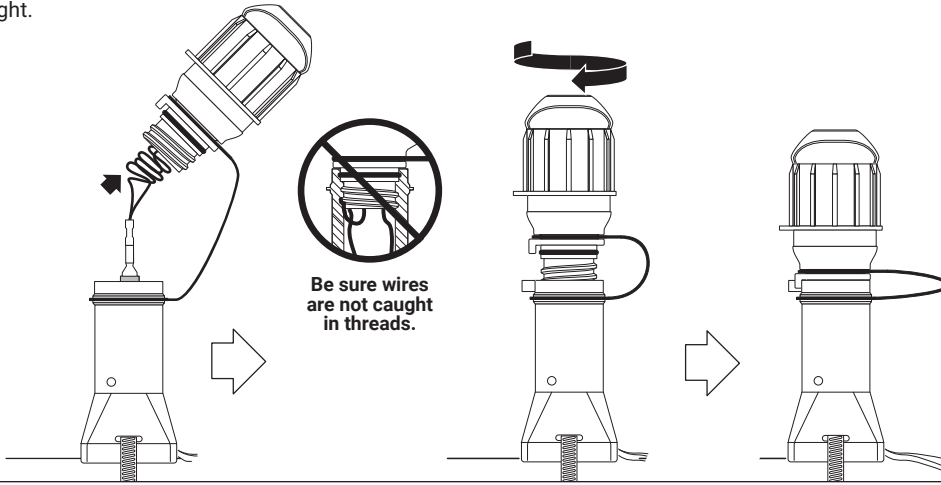

14

- Insert cable tie through the slot on stand and the slot on the light, then tighten.

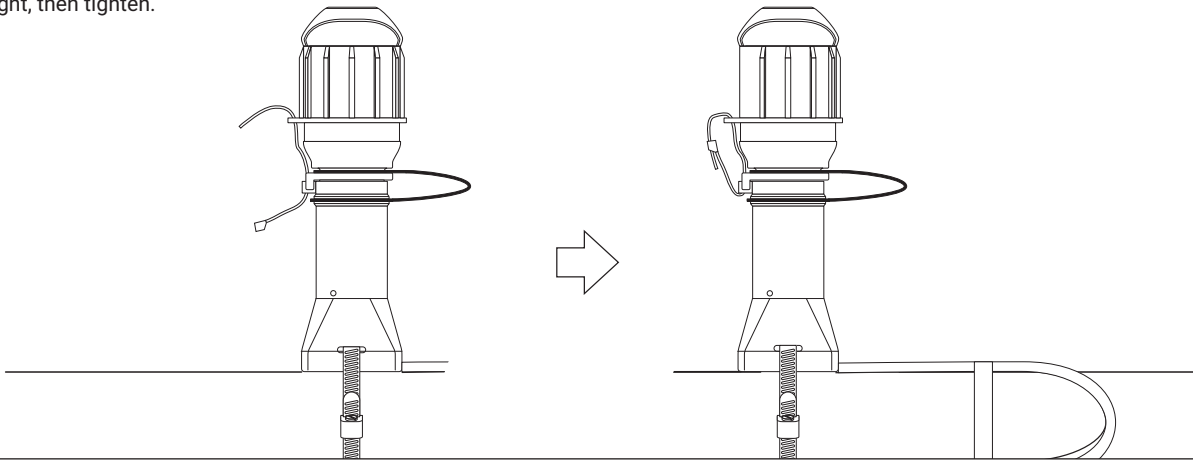

15

- Apply insulation and weather-seal the stand entry.
- Fasten end seal label to insulation.
- Leave these instructions with the end user for future reference.

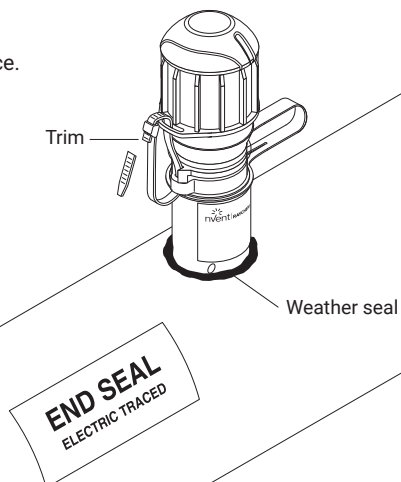

TROUBLESHOOTING GUIDE

Problem	Troubleshooting steps
Light is dim or off.	<ol style="list-style-type: none"> 1. Check that light voltage rating matches supply voltage for heat-tracing circuit. Supply voltage lower or higher than light rating will cause malfunctions. 2. Check that heat-tracing circuit is energized. Although the circuit breaker is on, control devices such as thermostats may switch heating cable off. 3. Following electrical safety procedures, disconnect supply voltage, unscrew light from end seal base and check that crimp connections to heating cable bus wires are tight and not crossed or shorted. Loose connections or shorts will cause malfunctions. 4. With circuit off, attach volt meter leads to crimps. Energize circuit and measure voltage at light. Use the following table to determine whether the voltage measured is within the acceptable range. <ul style="list-style-type: none"> – If voltage at light is in acceptable range and connections are good, the light may be defective or damaged. Replace light. – If there is no voltage at the light, there may be breaks in the heating cable between the power connection and the end seal. Check for splice or tee connections that may be left open. – If voltage at light is above specified limits, the light may be off. Voltages above specified range can damage light. Replace light with correct version for line supply voltage or adjust supply voltage accordingly. – If voltage at light is present but below specified limits, the light may be dim or off. The following table lists typical causes for low voltages and possible solutions.

Cause	Solution
Supply voltage at start of circuit is low (light is designed to work with supply voltages within 10% of nominal).	Increase power wire gauge size to reduce voltage drop between panel and heating cable power connection.
Heating cable length is too long (light is designed to work with published maximum circuit lengths).	Split heating cable into multiple circuits. Shorten length of heating cable.
Heating cable is started under very cold conditions (heating-cable voltage drop is very high for first minutes of very cold start-up).	Wait for heating cable to warm up. Voltage at light will increase.
Heating cable controller is reducing voltage (light may not work with controllers that phase fire to reduce line voltage).	Turn off phase firing function in heating cable controller.

Problem	Troubleshooting steps
Cap cannot be tightened completely.	<ol style="list-style-type: none"> 1. Check that heating cable is installed and stripped correctly. The top of the insulated parallel crimps should be 2% in (60 mm), or less, above the top of the plastic strain relief in the stand. 2. Check that core sealer is positioned properly. The end of the core sealer must be flush against the plastic strain relief in the stand. 3. Check that the threads on the light and stand are clean. The connection wires between the heating cable and the light should not be caught in stand threads.

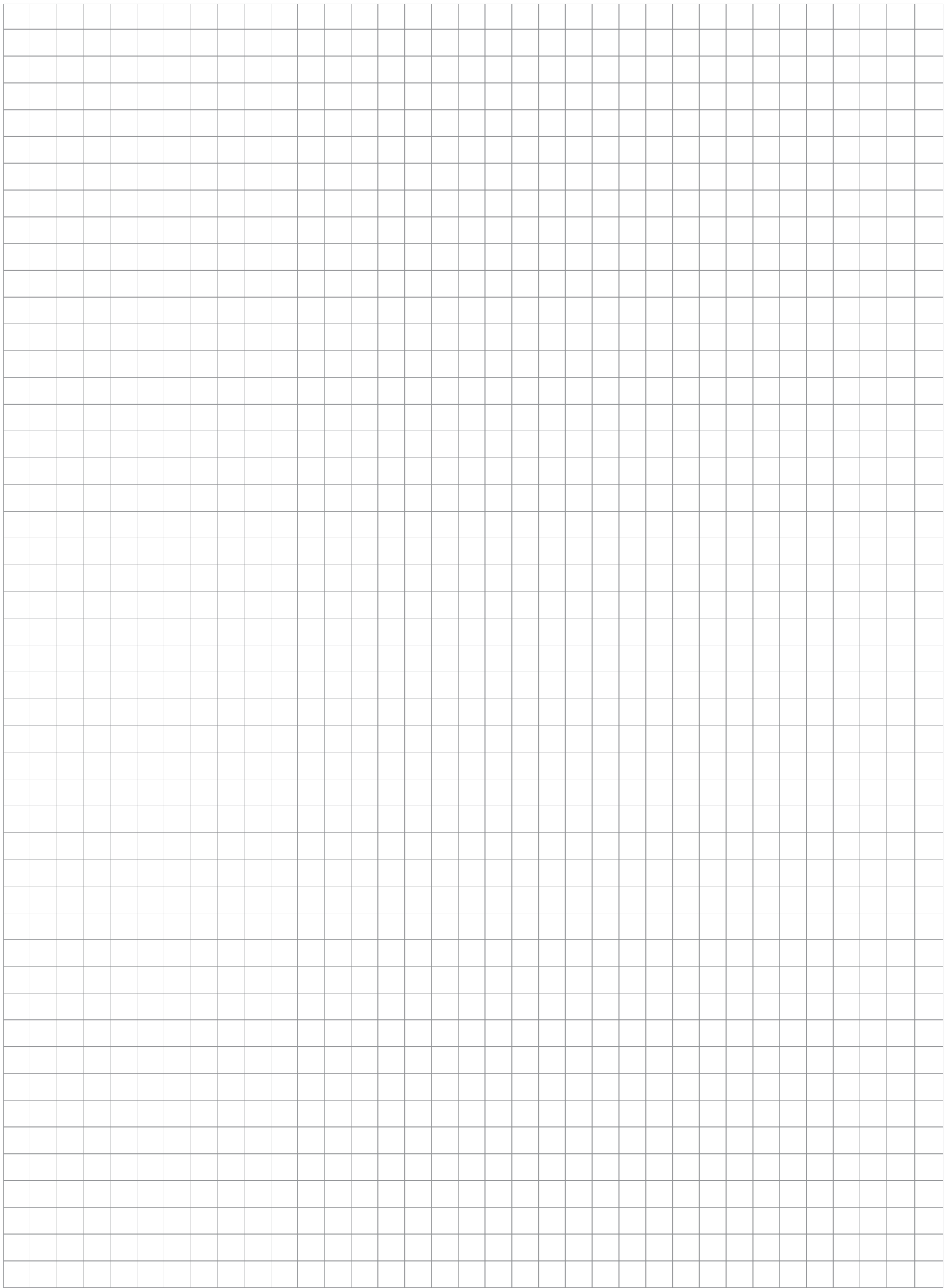

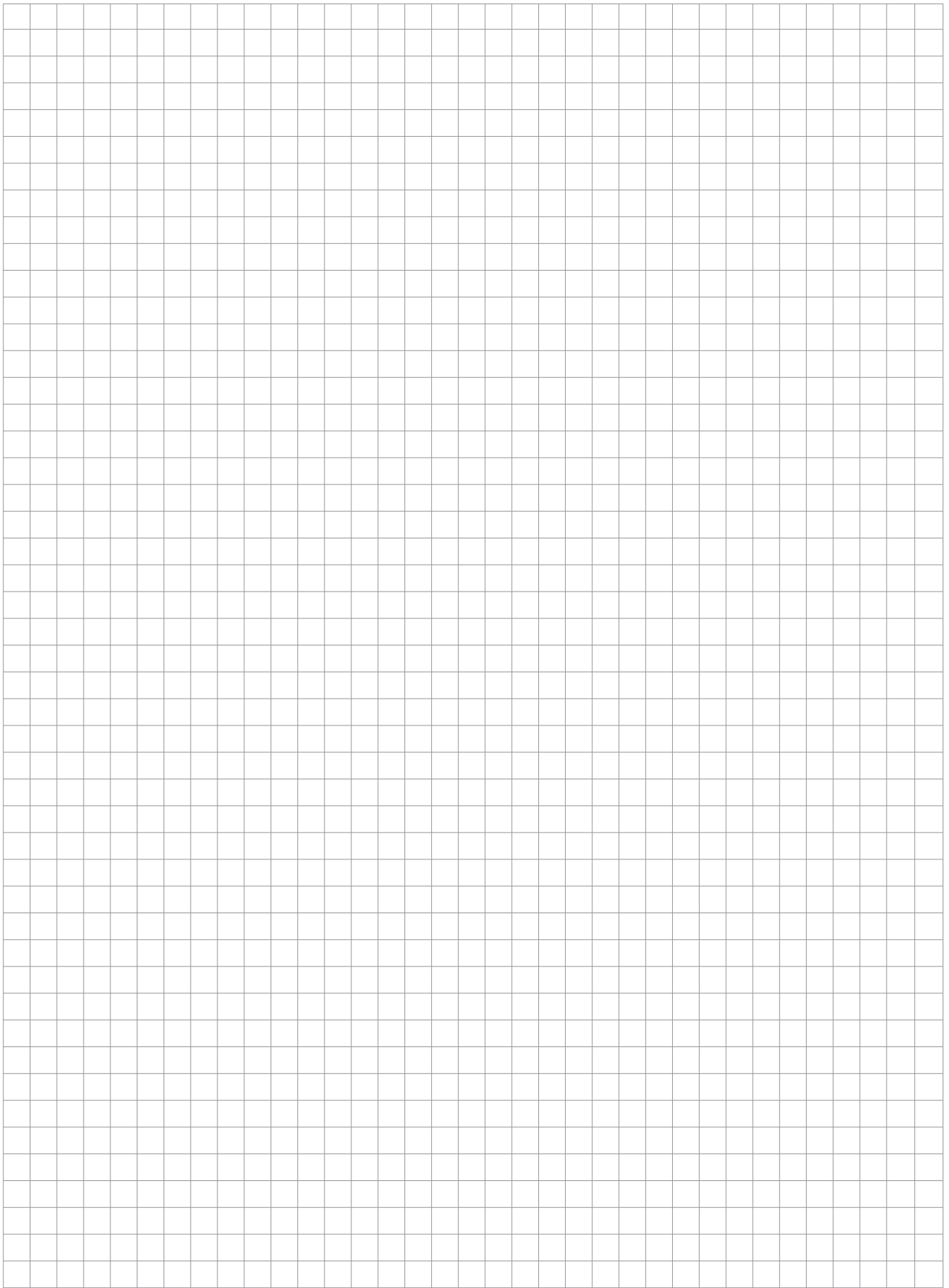

North America

Tel +1.800.545.6258
thermal.info@nVent.com



nVent.com/RAYCHEM