

THE INFORMATION CONTAINED IN THIS DRAWING IS THE SOLE PROPERTY OF CIS. ANY REPRODUCTION IN PART OR WHOLE WITHOUT WRITTEN PERMISSION OF CIS IS PROHIBITED.

ECN/ECO		PLACES	REV.	DESCRIPTION	SIGN	DATE
			E1	Design Release	WanBin Liu	2018-03-26

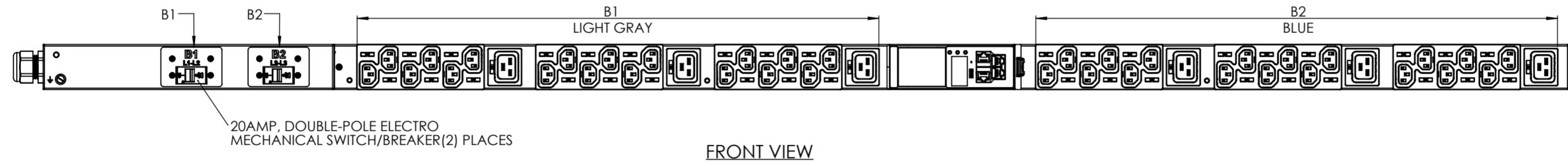
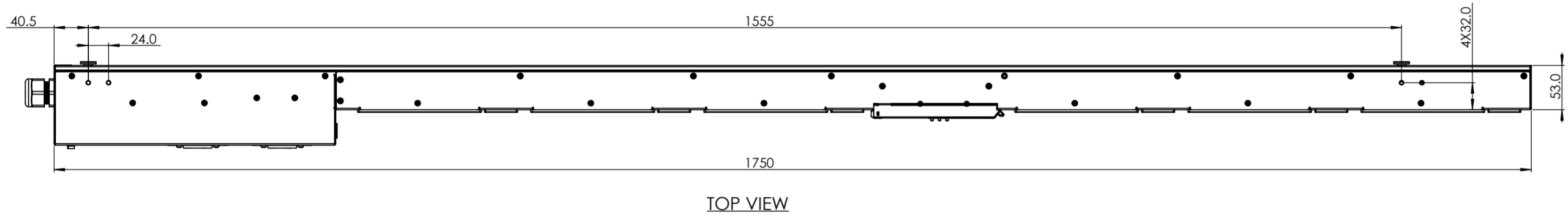
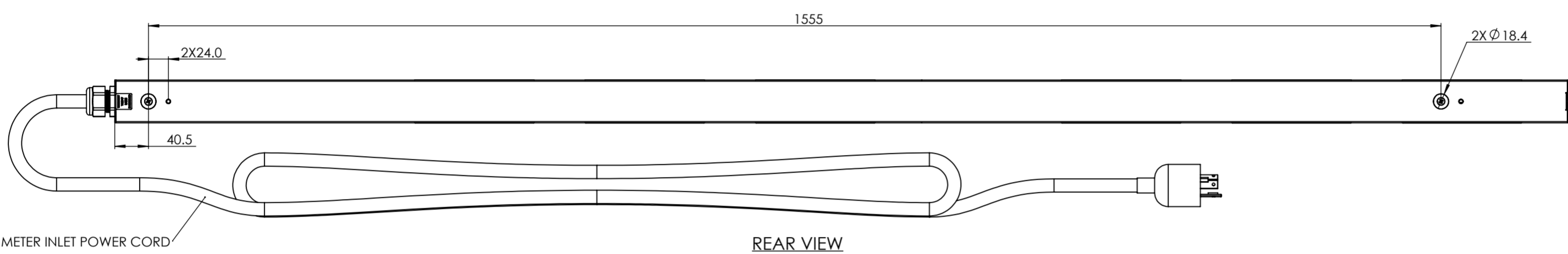
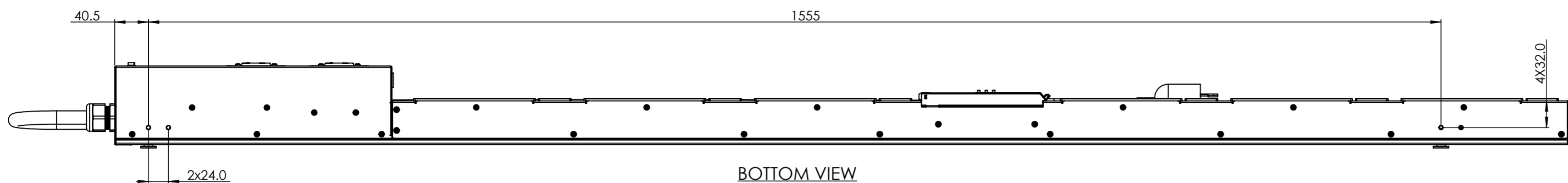

NOTES:
1.IDENTIFICATION:

TYPE:	INPUT METERED
ORIENTATION:	VERTICAL, 0U FULL
OUTLET QTY&TYPE:	(36) C13, (6) C19
BREAKER QTY&TYPE:	(2) 20AMP, DOUBLE-POLE
INPUT VOLTAGE:	200-240VAC
INPUT CURRENT:	30A (24A DERATED)
INPUT PHASE:	SINGLE-PHASE
RATED POWER:	5.0 kVA
INPUT PLUG:	NEMA L6-30P
INPUT POWER CORD:	3m[10'], TOP FEED
REGULATORY STANDARD:	RoHS COMPLIANT

PLUG
NEMA L6-30P, 2P 3W
30 A, 250V, MAX RATED INPUT
24A DERATED

RECEPTACLE
IEC 60320/C13
10A, 250V MAX RATED OUTPUT

RECEPTACLE
IEC 60320/C19
16A, 250V MAX RATED OUTPUT

<p>UNLESS NOTED, DIMENSIONS IN MILLIMETERS & TOLERANCES ARE:</p> <table border="0"> <tr> <td>X.</td> <td>± 1</td> <td>MM</td> <td></td> </tr> <tr> <td>X.X</td> <td>± 0.5</td> <td>MM</td> <td>X° ± 1°</td> </tr> <tr> <td>X.XX</td> <td>± 0.20</td> <td>MM</td> <td>X.X° ± 0.5°</td> </tr> <tr> <td>ØX.X</td> <td>± 0.4</td> <td>MM</td> <td></td> </tr> <tr> <td>ØX.XX</td> <td>± 0.20</td> <td>MM</td> <td></td> </tr> </table> <p>BRACKETED DIMENSIONS ARE IN INCHES FOR REFERENCE ONLY</p>	X.	± 1	MM		X.X	± 0.5	MM	X° ± 1°	X.XX	± 0.20	MM	X.X° ± 0.5°	ØX.X	± 0.4	MM		ØX.XX	± 0.20	MM		<p>DESIGNER & DATE: WanBin Liu 2019-03-26</p> <p>STANDARDIZATION/CHECKER & DATE: Hanson Xu 2019-03-28</p> <p>DFM & DATE: Talon Lv 2019-03-28</p> <p>APPROVER & DATE: Kanson Ren 2019-03-28</p>	<p>ASIA PACIFIC CIS WUXI CHINA</p>
	X.	± 1	MM																			
	X.X	± 0.5	MM	X° ± 1°																		
	X.XX	± 0.20	MM	X.X° ± 0.5°																		
ØX.X	± 0.4	MM																				
ØX.XX	± 0.20	MM																				
<p>ITEM WEIGHT (REFERENCE ONLY): g</p>	<p>DESCRIPTION: EN2.0 PDU</p>																					
<p>MATERIAL: g</p>	<p>P/N: TA-EN1315</p>																					
<p>IF 2D AND 3D DIFFER, 2D SHALL TAKE PRECEDENCE</p>	<p>SCALE 1:5 (DO NOT SCALE DRAWING) SIZE: A2 SHEET 1 OF 2</p>																					

THE INFORMATION CONTAINED IN THIS DRAWING IS THE SOLE PROPERTY OF CIS. ANY REPRODUCTION IN PART OR WHOLE WITHOUT WRITTEN PERMISSION OF CIS IS PROHIBITED.

enLOGIC

SKU #: EN1315
 Model #: EP11024-0016
 INPUT: 200-240VAC, 1PHASE, 50/60Hz, 24A
 OUTPUT: C13; 200-240VAC, 10A per outlet
 C19; 200-240VAC, 16A per outlet
 24A Total
 Mac Address: XX-XX-XX-XX-XX-XX

Power Distribution Unit

THIS DEVICE COMPLIES WITH PART 15 OF THE FCC RULES. OPERATION IS SUBJECT TO THE FOLLOWING TWO CONDITIONS:
 (1) THIS DEVICE MAY NOT CAUSE HARMFUL INTERFERENCE, AND
 (2) THIS DEVICE MUST ACCEPT ANY INTERFERENCE RECEIVED, INCLUDING INTERFERENCE THAT MAY CAUSE UNDESIRABLE OPERATION.
 CAN ICES-3(A)/NMB-3(A)

LISTED E44720 USED IN ITE

SKU#: EN1315

Serial Number: CNXXXXXX

Made In China

Mfr Name: ASIA PACIFIC CIS(WUXI)CO LTD

COMPLIANCE LABEL

- NOTES:**
1. INTERNAL WIRING:
- | | |
|---------------------|------------------------------|
| WIRE TYPE: | UL AWM 1015, 10 & 12 & 18AWG |
| LINE 1/R/X COLOR: | BLACK |
| EARTH GROUND COLOR: | GREEN STRIPE |
| LINE 2/S/Y COLOR: | RED |

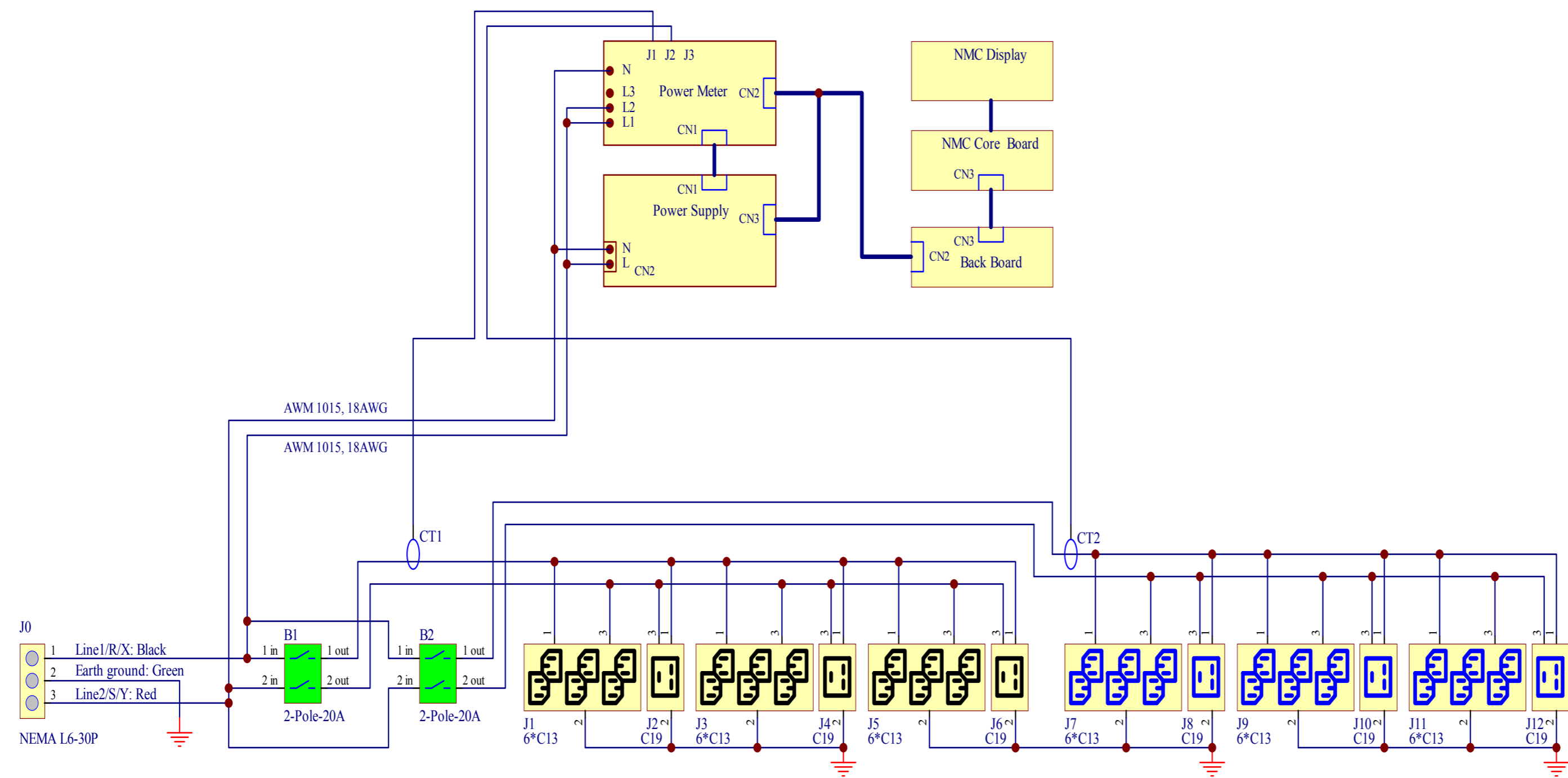

INTERNAL WIRING SCHEMATIC

<p>UNLESS NOTED, DIMENSIONS IN MILLIMETERS & TOLERANCES ARE:</p> <p>X. ± 1 MM</p> <p>X.X ± 0.5 MM</p> <p>X.XX ± 0.20 MM</p> <p>ØX.X ± 0.4 MM</p> <p>ØX.XX ± 0.20 MM</p> <p>BRACKETED DIMENSIONS ARE IN INCHES FOR REFERENCE ONLY</p> <p>THIRD ANGLE PROJECTION</p> <p>IF 2D AND 3D DIFFER, 2D SHALL TAKE PRECEDENCE</p>	<p>DESIGNER & DATE:</p> <p>Wanbin Liu 2019-3-26</p>		<p>DESCRIPTION:</p> <p style="text-align: center; font-size: 1.2em;">EN2.0 PDU</p>		
	<p>STANDARDIZATION/CHECKER & DATE:</p> <p>Hanson Xu 2019-3-28</p>			<p>REV:</p> <p style="font-size: 1.2em;">E1</p>	
	<p>APPROVER & DATE:</p> <p>Kanson Ren 2019-3-28</p>	<p>ITEM WEIGHT (REFERENCE ONLY):</p> <p style="text-align: center;">Assembly</p>		<p>P/N:</p> <p style="font-size: 1.2em;">TA-EN1315</p>	<p>SCALE 1:5 (DO NOT SCALE DRAWING)</p>
	<p>MATERIAL:</p> <p style="text-align: center;">Assembly</p>	<p>SIZE: A2</p>		<p>SHEET 2 OF 2</p>	