

Osservazioni - Notes:

07	12-02-19	Ottava emissione / Eighth execution	Tanadini Nicola	Descrizione / Description: Electrical Diagram EGOA5NT	Eseguito da / Designer	Tanadini Nicola
06	10-07-17	Settima emissione / Seventh execution	Tanadini Nicola		Data / Date:	10/07/2017
05	12-01-17	Sesta emissione / Sixth execution	Tanadini Nicola		Codice / Code:	TSE299
Rev.	Data/Date	Descrizione modifica / Modification	Eseguito da / Designer	Page 1 of 5	Rev. / Revision:	07

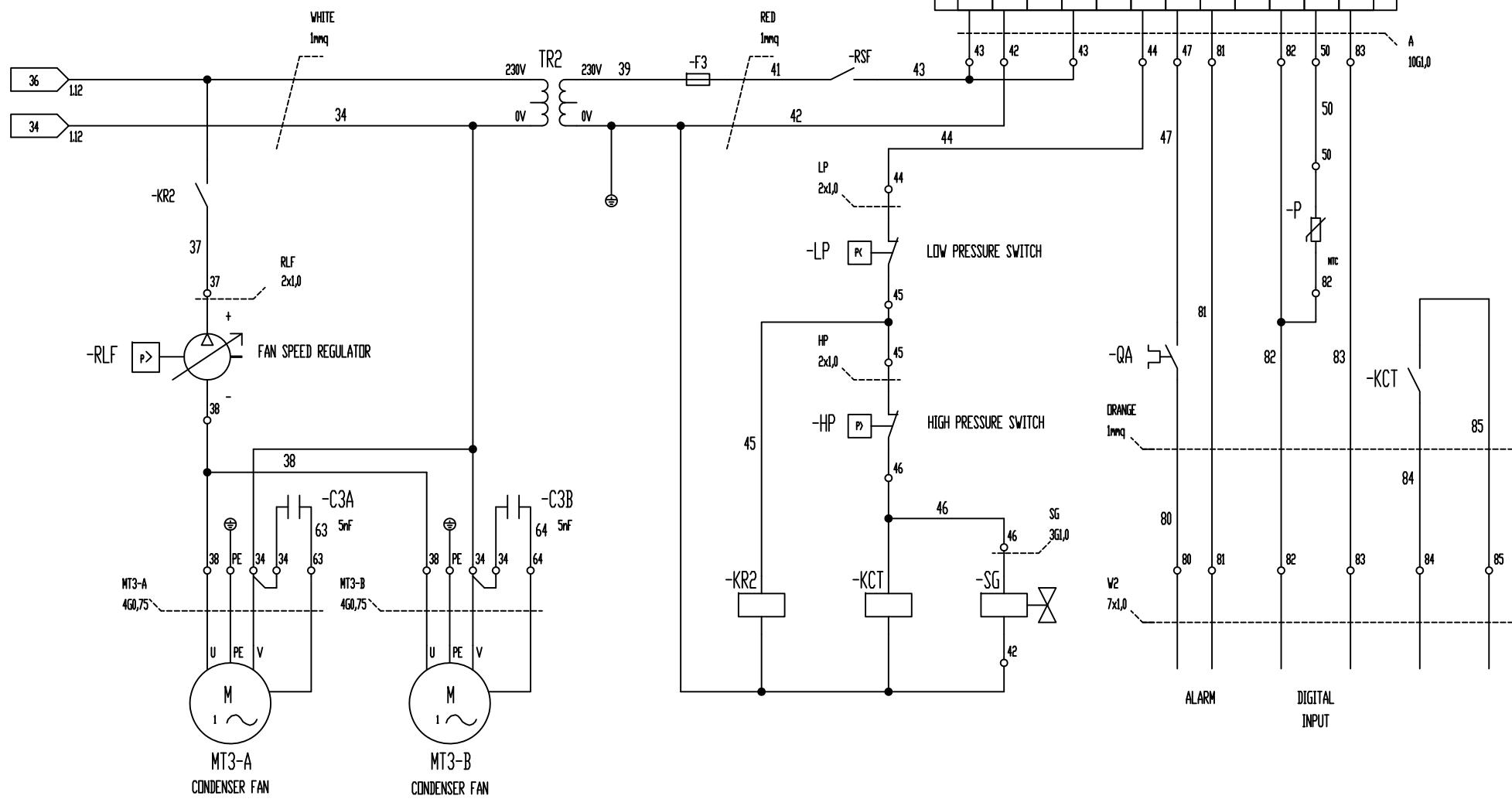

TEXA INDUSTRIES S.r.l.
 STRADA CA' BRUCIATA, 5
 46020 PEGOGNAGA MANTOVA ITALY
 TEL. +39 0376-554511
 www.texaindustries.com



Osservazioni - Notes:

07	12-02-19	Ottava emissione / Eighth execution	Tanadini Nicola	Descrizione / Description: Electrical Diagram EGOA5NT	Eseguito da / Designer	Tanadini Nicola
06	10-07-17	Settima emissione / Seventh execution	Tanadini Nicola		Data / Date:	10/07/2017
05	12-01-17	Sesta emissione / Sixth execution	Tanadini Nicola		Codice / Code:	TSE299
Rev.	Data/Date	Descrizione modifica / Modification	Eseguito da / Designer	Page 2 of 5	Rev. / Revision:	07

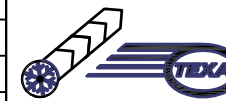

TEXA INDUSTRIES S.r.l.
 STRADA CA' BRUCIATA, 5
 46020 PEGOGNAGA MANTOVA ITALY
 TEL. +39 0376-554511
 www.texaindustries.com

MORSETTIERA

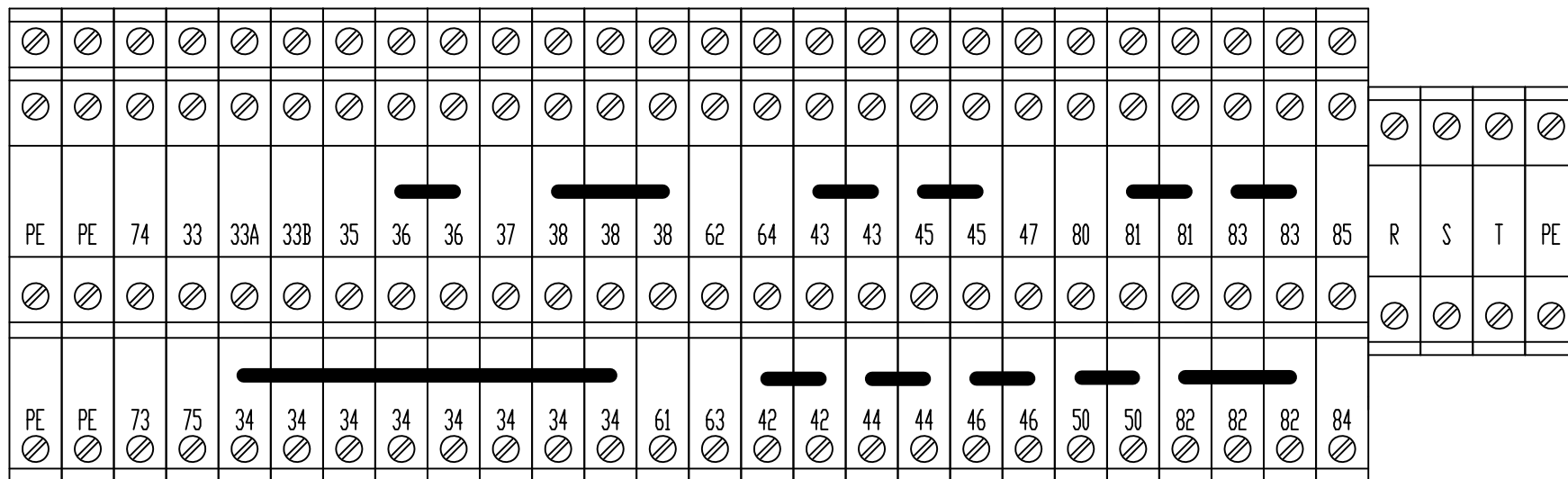

Osservazioni - Notes:

07	12-02-19	Ottava emissione / Eighth execution	Tanadini Nicola	Descrizione / Description: Electrical Diagram EGOA5NT	Eseguito da / Designer	Tanadini Nicola
06	10-07-17	Settima emissione / Seventh execution	Tanadini Nicola		Data / Date:	10/07/2017
05	12-01-17	Sesta emissione / Sixth execution	Tanadini Nicola		Codice / Code:	TSE299
Rev.	Data/Date	Descrizione modifica / Modification	Eseguito da / Designer	Page 3 of 5	Rev. / Revision:	07

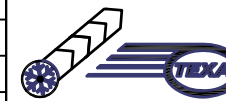

TEXA INDUSTRIES S.r.l.
 STRADA CA' BRUCIATA, 5
 46020 PEGGIGNAGA MANTOVA ITALY
 TEL. +39 0376-554511
www.texaindustries.com



LISTA APPARECCHI / COMPONENTS LIST

N°	Simb.	Q.ta Q.ty	Descrizione - Description	Modello - Model	Codice - Code	N°	Simb.	Q.ta Q.ty	Descrizione - Description	Modello - Model	Codice - Code
1	QA	1	Interruttore magnetotermico - Magnetothermic switch 11-16A	ABB	MS132-16	21	SG	1	Valvola solenoide gas - Solenoid valve gas	Totaline	C15000540
2	KCT	1	Contattore - Contact-breaker 7.5kW	ABB	AF16-30-10-13	22	TR2	1	Trasformatore - Transformer	50VA 0-230/0-230V	
3	F1	1	Porta fusibile - Fuse holder	Wimex	PS 10-2-S	23	KR2	1	Relay ventole condensanti - Condenser fans relay	Finder	
4	F1	2	Fusibile - Fuse	4 A	-	24					
5	F2	1	Porta fusibile - Fuse holder	Wimex	PS 10-1-S	25					
6	F2	1	Fusibile - Fuse	6 A	-	26					
7	F3	1	Porta fusibile - Fuse holder	Wimex	PS 10-1-S	27					
8	F3	1	Fusibile - Fuse	1A	-	28					
9	TR	1	Autotrasformatore - Autotransformer	1200VA 400-460/230V	C12000226	29					
10	MT1	1	Compressore - Compressor	Sanyo	C14000166	30					
11	MT2	2	Ventil. evaporatore - Evaporator fan	Soler & Palau	C14000545	31					
12	MT3	2	Ventil. condensatore - Condenser fan	EBM	C14000181	32					
13	C2	2	Condensatore ventola evaporante - Evaporator fan capacitor	5µF	C16000039	33					
14	C3	2	Condensatore ventola condensante - Condenser fan capacitor	5µF	C16000039	34					
15	RSF	1	Relay sequenza fasi - Phase sequence relay	LOVATO	PMV20A575	35					
16	A	1	Termostato digitale - Digital thermostat	TX050	C16000259	36					
17	P	1	Sonda NTC - NTC Probe			37					
18	P1	1	Pressostato di bassa pressione - Low pressure switch	Alco Controls	C16000307	38					
19	P2	1	Pressostato di alta pressione - High pressure switch	Alco Controls	C16000306	39					
20	RLF	1	Regolatore di velocità pressostatico - Pressostatic fan speed regulator	Alco Controls	C16000866	40					

Osservazioni - Notes:

07	12-02-19	Ottava emissione / Eighth execution	Tanadini Nicola	Descrizione / Description:	Eseguito da / Designer	Tanadini Nicola		TEXA INDUSTRIES S.r.l. STRADA CA' BRUCIATA, 5 46020 PEGOGNAGA MANTOVA ITALY TEL. +39 0376-554511 www.texaindustries.com
06	10-07-17	Settima emissione / Seventh execution	Tanadini Nicola	Electrical Diagram EGOA5NT	Data / Date:	10/07/2017		
05	12-01-17	Sesta emissione / Sixth execution	Tanadini Nicola		Codice / Code:	TSE299		
Rev.	Data/Date	Descrizione modifica / Modification	Eseguito da / Designer	Page 4 of 5	Rev. / Revision:	07		

Proprietà della TEXA INDUSTRIES S.r.l. - Senza autorizzazione scritta, questo disegno non potrà essere comunque utilizzato per la costruzione dell'oggetto rappresentato né venire comunicato a terzi o riprodotto. La società proprietaria tutela i propri diritti a rigore di legge.

LISTA CAVI ELETTRICI / CABLE LIST

N°	Simb.	Descrizione	Lunghezza	Sezione	N°	Simb.	Descrizione	Lunghezza	Sezione
1	W1	Cavo alimentazione Power supply cable	7000 mm	4G2,5					
2	W2	Cavo segnali Signal cable	7000 mm	7x1,0					
3	MT1	Cavo collegamento compressore Compressor cable	800 mm	4G2,5					
4	MT2-A	Cavo collegamento ventola evaporante Evaporator fan cable	2000 mm	4G0,75					
5	MT2-B	Cavo collegamento ventola evaporante Evaporator fan cable	2000 mm	4G0,75					
6	MT3-A	Cavo collegamento ventola condensante Condenser fan cable	2700 mm	4G0,75					
7	MT3-B	Cavo collegamento ventola condensante Condenser fan cable	2700 mm	4G0,75					
8	HP	Cavo collegamento pressostato di alta High pressure switch cable	1300 mm	2x1,0					
9	LP	Cavo collegamento pressostato di bassa Low pressure switch cable	1000 mm	2x1,0					
10	TR	Cavo collegamento autotrasformatore Autotransformer cable	500 mm	4x1,5					
11	RLF	Cavo collegamento regolatore di velocità pressostatico Pressostatic speed regulator cable	1000 mm	2x1,0					
12	SG	Cavo collegamento valvola solenoide Solenoid valve cable	1000 mm	3G1,0					
13	A	Cavo collegamento termostato elettronico Electronic thermostat cable	1500 mm	10G1,0					
14	PE	Cavo di terra Ground cable	500 mm	1x2,5					
15									
16									
17									
18									
19									
20									

Osservazioni - Notes:

07	12-02-19	Ottava emissione / Eighth execution	Tanadini Nicola	Descrizione / Description: Electrical Diagram EGOA5NT	Eseguito da / Designer	Tanadini Nicola
06	10-07-17	Settima emissione / Seventh execution	Tanadini Nicola		Data / Date:	10/07/2017
05	12-01-17	Sesta emissione / Sixth execution	Tanadini Nicola		Codice / Code:	TSE299
Rev.	Data/Date	Descrizione modifica / Modification	Eseguito da / Designer	Page 5 of 5	Rev. / Revision:	07

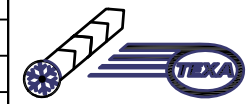

TEXA INDUSTRIES S.r.l.
 STRADA CA' BRUCIATA, 5
 46020 PEGOGNAGA MANTOVA ITALY
 TEL. +39 0376-554511
 www.texaindustries.com

