



SYSTEM 1850 2-HOUR FIRE-RATED CABLE SYSTEM

This section provides an overview of general circuit design considerations and installation guidelines for nVent PYROTENAX Fire-Rated Cables. For additional information, contact your nVent representative or call nVent at (800) 545-6258. Also, visit our website at nVentthermal.com.

CONTENTS

- INTRODUCTION 1**
- Typical Applications..... 2
- Typical Locations 2
- System 1850 2
- Approvals and Certifications 3
- FIRE ALARM CIRCUITS..... 4**
- Fire Alarm Circuit Design Considerations..... 4
- Installation Guidelines..... 5
- CRITICAL POWER CIRCUITS 7**
- Circuit Design Considerations..... 7
- Typical System Installation 11
- INSTALLATION GUIDELINES 11**

INTRODUCTION

nVent PYROTENAX System 1850 mineral insulated (MI) wiring cables meet the relevant requirements of the U.S. National Electrical Code (NEC), the National Fire Alarm Code, the Canadian Electrical Code (CEC), and the Canadian National Building Code for fire protection of emergency power feeders and fire alarm circuits. The codes stipulate that a reliable source of power is required to operate all critical life safety circuits necessary to provide time for a safe evacuation of building occupants and to allow emergency crews to effectively control the fire. Fire-resistance ratings of 1-hour or 2-hours are required depending on national and local codes, the type of circuit, and the environment.

Typical Applications

nVent fire-rated wiring cables meet the most stringent requirements for 2-hour fire rating, allowing for the highest degree of fire protection for emergency back-up power supply systems, emergency equipment, and fire alarm systems. In the event of a fire, electrical power and communication is preserved for critical life safety circuits. These critical circuits provide power for:

- Fire pumps – to maintain pressure in the sprinkler system
- Firefighters' elevators
- Smoke dampers and pressurization fans – to maintain smoke-free areas for egress
- Smoke extraction fans
- Emergency lighting and exit signs
- Fire alarm and voice communication systems

Typical Locations

Typical locations requiring emergency power feeders include:

- High-rise buildings
- Hospitals and other institutions
- Historic buildings
- Tunnels and subways
- Airports, stadiums, hotels, banks, etc.

System 1850

System 1850 2-hour fire-rated MI cable offers a unique combination of dependability, versatility, and permanence while withstanding continuous operating temperatures as high as 250°C (482°F) and intermittent exposure temperatures as high as 1010°C (1850°F).

Featuring “zero smoke, zero flame spread, zero fuel contribution” and up to 80% space savings compared to conventional conduit and wire systems, System 1850 MI cable is the preferred choice for many specifiers. The ease with which this tough cable can be pulled into difficult runs with tight corners makes it an ideal choice for many applications. System 1850 MI cable may be installed in virtually any location: outdoors, submersed, or buried with a protective over-jacket. The cable can be bent, twisted, or pulled, and can withstand mechanical abrasion while remaining fully functional.

System 1850 MI power cables are 2-hour fire-rated to ANSI/UL 2196 / ULC-S139 fire test standards. System 1850 fire alarm cables are 2-hour fire rated to ULC-S139 fire test standard (Canada only). UL2196 and ULC-S139 fire test standards utilize the ASTM E-119 time-temperature curve: the test requires that cables remain operational after exposure to temperatures up to 1010°C (1850°F) for two hours followed by the full force of a firefighter's hose stream. System 1850 MI cable passes this rigorous circuit integrity test without additional mechanical protection.

CABLE CONSTRUCTION

System 1850 MI cables are manufactured using only inorganic materials, copper and magnesium oxide. This construction is inherently tough, yet allows the cable to be bent and molded to fit into tight spaces. In addition, the totally inorganic construction of unjacketed System 1850 MI cable allows for an environmentally clean electrical cable that does not burn, produce smoke, or contribute fuel when exposed to fire conditions.

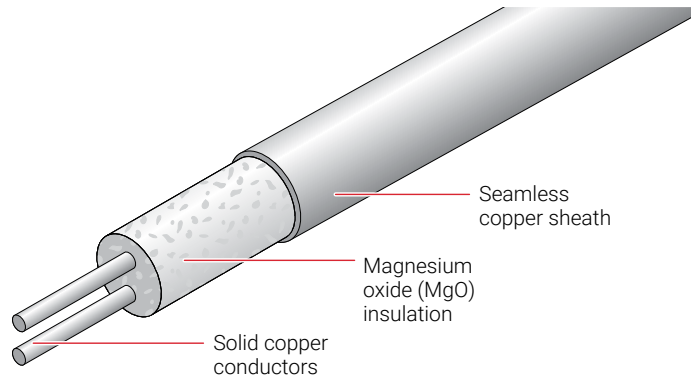

Fig. 1 System 1850 MI cable construction

For superior corrosion protection, an optional polymer jacket is available and is suitable for use in temperatures as low as -40°C (-40°F).

CONFIGURATIONS

System 1850 fire-rated MI cables are available in a range of sizes and conductor configurations for power feeders and in twisted pair configurations for fire alarm circuits.

Approvals and Certifications

PYROTENAX SYSTEM 1850 MI CABLE

System 1850 power MI cables meet the requirements of the circuit integrity fire test, ANSI/UL 2196 (ULC-S139 in Canada), and are UL Listed and CSA Certified in North America.

The details of this system appear in the online UL and ULC Fire Resistance Directories as Electrical Circuit Integrity System (FHIT and FHIT7) System No. 1850.

System 1850 fire alarm MI cables meet the requirements of the ULC-S139 circuit integrity fire test and are cUL Listed (Canada only) and CSA Certified in North America.

The details of this system appear in the online ULC Fire Resistance Directory as Electrical Circuit Integrity System (FHIT7) System No. 1850.

Factory terminated MI cable sets are approved for both nonhazardous locations and hazardous locations. For specific approval information, refer to the System 1850 data sheet for factory terminated cables, H57048.

OUTSIDE NORTH AMERICA

nVent PYROTENAX fire-rated fire alarm and power cables are also available for use outside North America, and are LPCB certified to BS EN 60702-1, BS 6387 Categories C, W, and Z, BS EN 50267-2-1, BS EN 50200, BS 8434-2 and BS 5839-1 for standard and enhanced grades of cable. These products carry the CE Mark and are approved to local standards. Contact nVent for information on our range of cables certified for use worldwide.

The following general guidelines relate to the design and installation of fire alarm circuits utilizing System 1850 MI cables.

Fire Alarm Circuit Design Considerations

Fire alarm systems should only be designed by professionals familiar with generally accepted design practices. The information provided below relates specifically to designs using nVent fire alarm cables and must be followed, along with all relevant local codes and standards, to ensure that the systems are designed properly. For additional information, contact your nVent representative or call nVent at (800) 545-6258.

CABLE SIZING

Primarily data and signal communications, these circuits are low voltage and low current, utilizing 18 AWG and 16 AWG conductors.

Cable sizing should be in accordance with the fire alarm system manufacturers' recommendations.

CABLE TERMINATION AND SPLICES

When using System 1850 shielded twisted pair cables, the drain wire is connected to the metallic inner shield. At each junction box, the drain wires are connected together, but not grounded; the shield drain wire is only grounded at one point in the circuit.

System 1850 MI fire alarm cables are approved as a complete system only when used with the appropriate nVent PYROTENAX termination and splice kits. The use of nonapproved components may compromise the reliability of the system and will invalidate approvals and warranties.

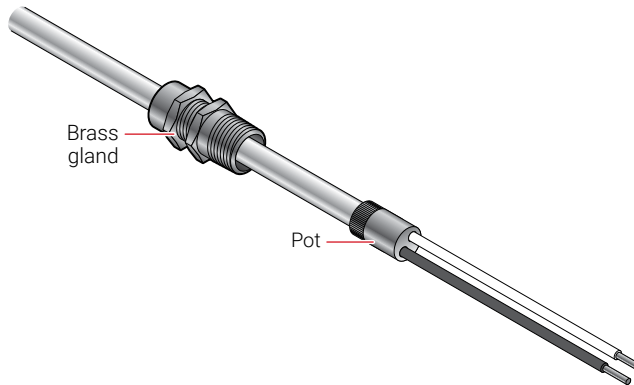

Fig. 2 System 1850 MI cable termination

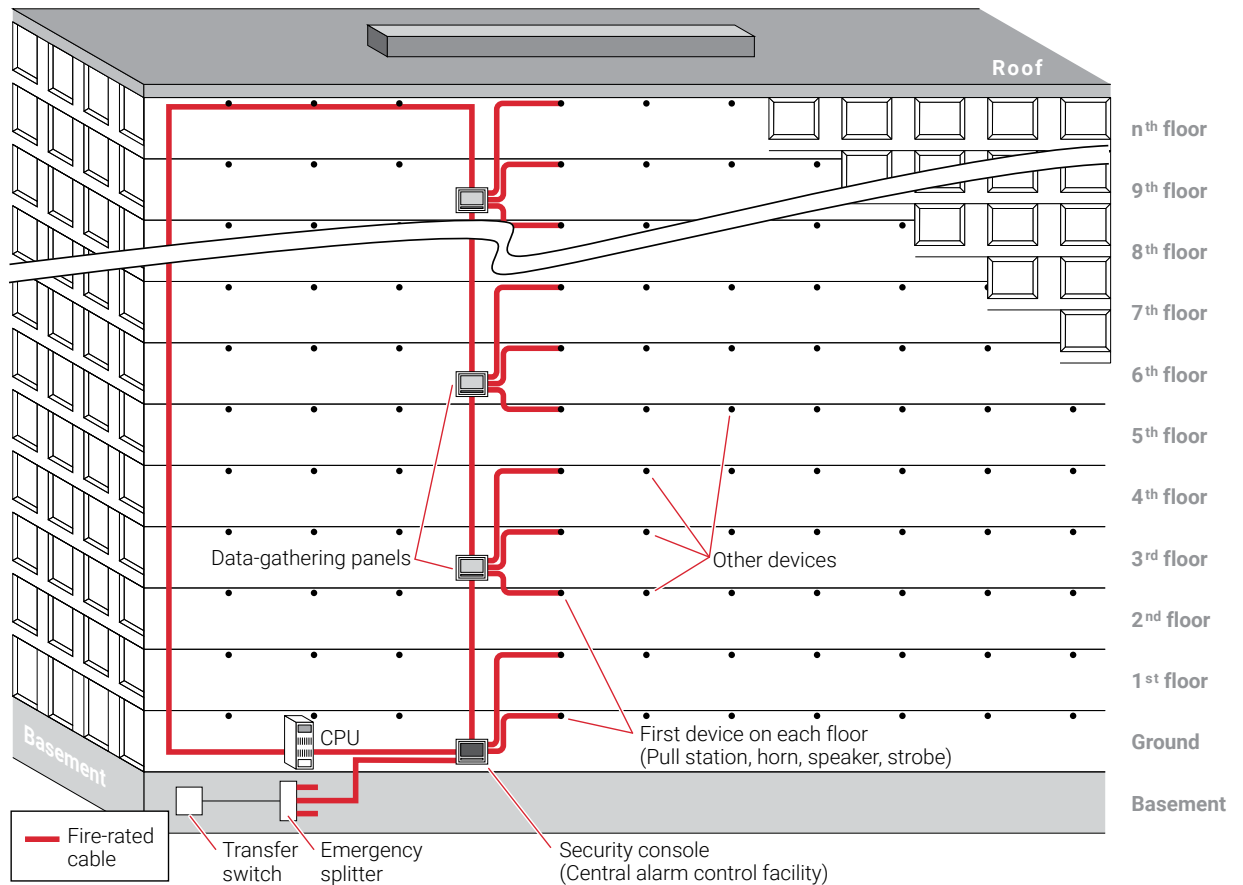

Fig. 3 Typical fire alarm system

Installation Guidelines

These installation guidelines apply to System 1850 MI cables only. When installing a system, refer to the requirements in the UL/ULC Fire Resistance Directory and the appropriate System 1850 data sheets, or installation instructions shipped with the product, and available on the nVent website at nVentthermal.com.

SUPPORTING FIRE ALARM CABLE

It is important that all support components are made of appropriate materials, such as copper, steel, stainless steel, and concrete. Low melting point or combustible materials such as aluminum, brass, plastic, lead, wood, etc. are not acceptable.

System 1850 MI cables may be directly mounted on noncombustible surfaces such as concrete or masonry, or supported by steel rod and channel (trapeze) systems. UL/ULC listing requirements for fire-rated cables stipulate support spacing at certain intervals; refer to the installation instructions shipped with the product and available on the nVent website at nVentthermal.com.

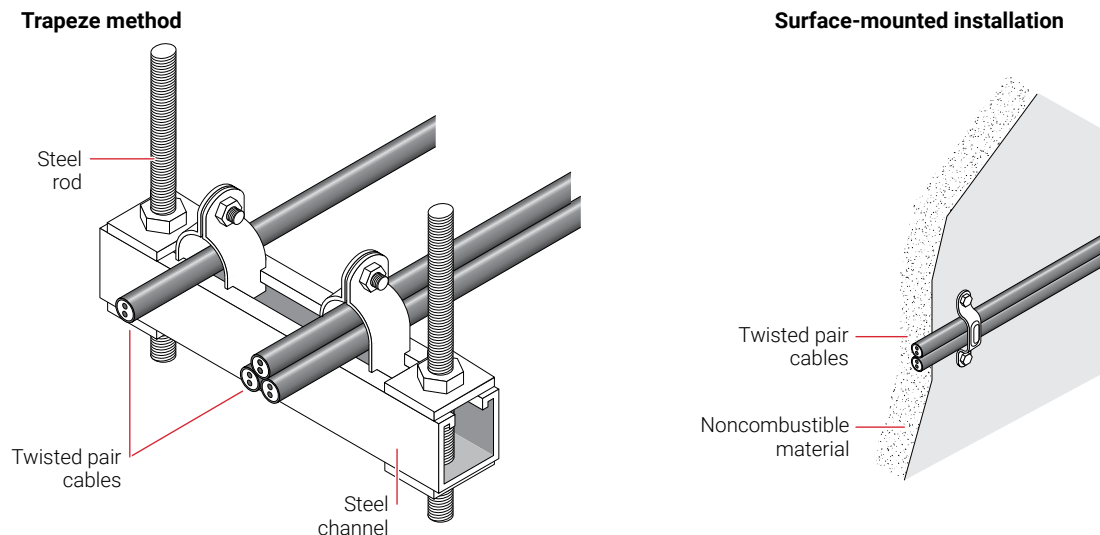

Fig. 4 Typical fire alarm installations for System 1850 MI cable

SEISMIC CONSIDERATIONS

In areas where there is a risk of seismic activity, precautions must be taken where the cable crosses expansion joints and at termination points. For more information, refer to the document for MI Cable Expansion and Vibration, H57613.

TERMINATING FIRE ALARM CABLE

Details on terminating System 1850 MI cables can be found in the installation instructions provided with each System 1850 MI fire alarm cable termination kit. Factory terminated System 1850 MI cable sets are available. For details on terminated cable sets, contact your nVent representative or call nVent at (800) 545-6258.

CONNECTING FIRE ALARM CABLE

For System 1850 fire alarm cables, the termination gland is a brass fitting available in 1/2" and 3/4" NPT sizes, depending on the cable diameter.

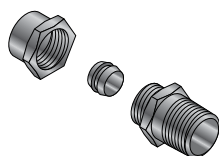

Fig. 5 Brass gland

Gland size information for each specific cable is available from the System 1850 Twisted Pair Cable data sheet, H57473. When tightened with the recommended torque, 25 ft-lbs for all gland sizes, this gland simultaneously seals the enclosure and grips the cable through a brass compression sleeve.

The following general guidelines relate to the design and installation of critical power circuits utilizing System 1850 cables.

Circuit Design Considerations

Critical power circuit systems should only be designed by professionals familiar with generally accepted design practices. The information provided below relates specifically to designs using nVent PYROTENAX power cables and must be followed, along with all relevant local codes and standards, to ensure that the systems are designed properly. For further information, contact your nVent representative or call nVent at (800) 545-6258.

CABLE SIZING

System 1850 MI cable size is based on circuit breaker size, which in turn is based on load calculations. Special rules apply for motors, including fire pumps, where cable size is based on 125% of full load current. Use the ampacity tables specified in the electrical code to determine the cable size. If the calculated voltage drop exceeds the specified limits, a larger cable size must be chosen.

Multiconductor MI cables have the same ampacity ratings as cable in conduit or other multiconductor cable types. However, the NEC and CEC allow full "free air" ampacity for unjacketed single conductor MI cables configured according to Fig. 6 as long as a space of 2.15 cable diameters is maintained between bundles.

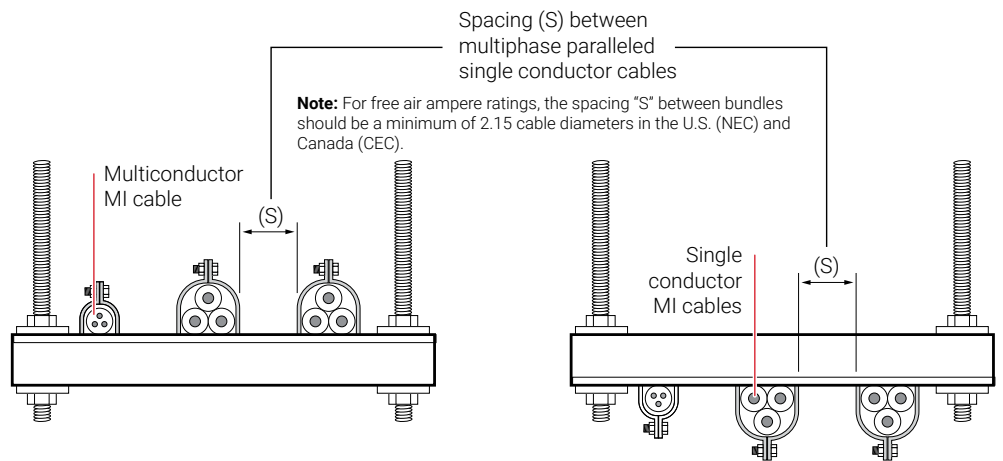

Fig. 6 Spacing of bundled conductors

Although unjacketed single conductor MI cable is unaffected by any temperature increase resulting under the installation conditions shown in Fig. 6, the termination may need to be "sized-up" to keep it within its temperature limits in accordance with electrical code requirements. Refer to the installation instructions shipped with the product for details on sizing up MI cable terminations.

VOLTAGE DROP

Voltage drop calculations are based on calculated load, not circuit breaker rating.

For conventional cables, simple formulas are used to determine if the cable size listed in the ampacity tables meets the required voltage drop limits. While these formulas can be applied to System 1850 MI cable, voltage drop values specific to the characteristics of MI cable can be calculated using any of the following:

- An equation based on the run length, the conductor current, and the circuit voltage is provided in the document for MI Cable Voltage Drop Calculations, H57611.
- A quick voltage drop calculator is available on the nVent website at nVentthermal.com.
- PyroSizer MI cable sizing software is available on the nVent website at nVentthermal.com, or through your nVent representative.

EQUIPMENT BONDING

The copper sheath of System 1850 MI cables meets North American code requirements for the equipment grounding conductor. The brass gland completes the grounding path from the cable sheath to the equipment. For single conductor cables, the ground path includes a nonferrous brass plate, as shown in Fig. 7 (in Canada, brass plates are required only for ampacities over 200 A).

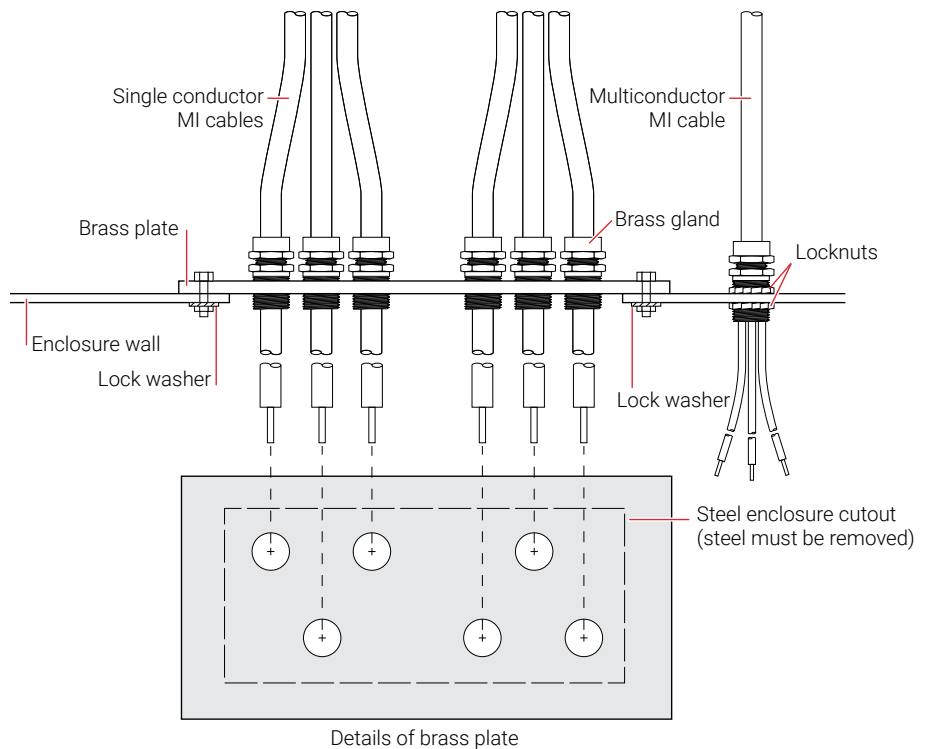

Fig. 7 Equipment bonding using brass plate

SHORT CIRCUIT CAPABILITY

The following graphs give the maximum allowable short circuit currents for System 1850 MI cables. The first is based on the cable only. The cable will survive if the short circuit currents shown are not exceeded; however, the terminations could be damaged. The second graph provides the maximum short circuit current to avoid damage to terminations.

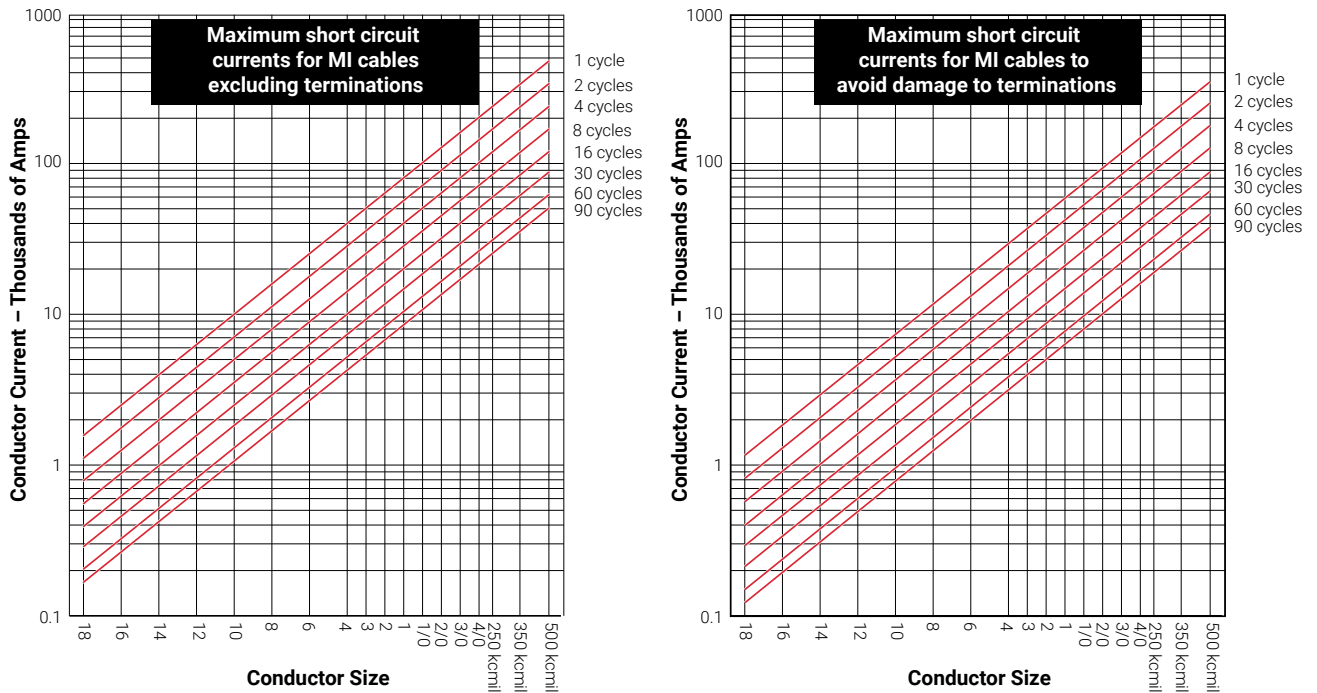

Fig. 8 Short circuit currents

EXPANSION AND VIBRATION

In applications subject to expansion or vibration, take precautions to prevent mechanical damage to System 1850 MI cable. For more information, refer to the document for MI Cable Expansion and Vibration, H57613.

CORROSION AND COPPER-ARMORED CABLES

In most applications, System 1850 MI cables can be used without any additional protection against corrosion. However, in applications where the cable may be exposed to corrosives, such as when the cable is directly buried or embedded in concrete, additional protection in the form of a polymer jacket is required. For more information, refer to the document for Copper Sheathed Cable and Corrosion, H57614.

CABLE TERMINATION AND SPLICES

System 1850 MI cables are approved as a complete system only when used with the appropriate termination and splice kits. The use of nonapproved components will compromise the reliability of the system and will invalidate approvals and warranties.

Two types of termination kits are available: Pyropak kits for all single and multiconductor cables, and QuickTerm kits for #6 AWG and larger single conductor cables. The QuickTerm kits include a special connector to splice the solid MI conductor to a flexible tail (flexible tail not supplied).

Factory terminated System 1850 MI cable sets are available in a range of sizes and lengths. For details on terminated cable sets, contact your nVent representative or call nVent at (800) 545-6258.

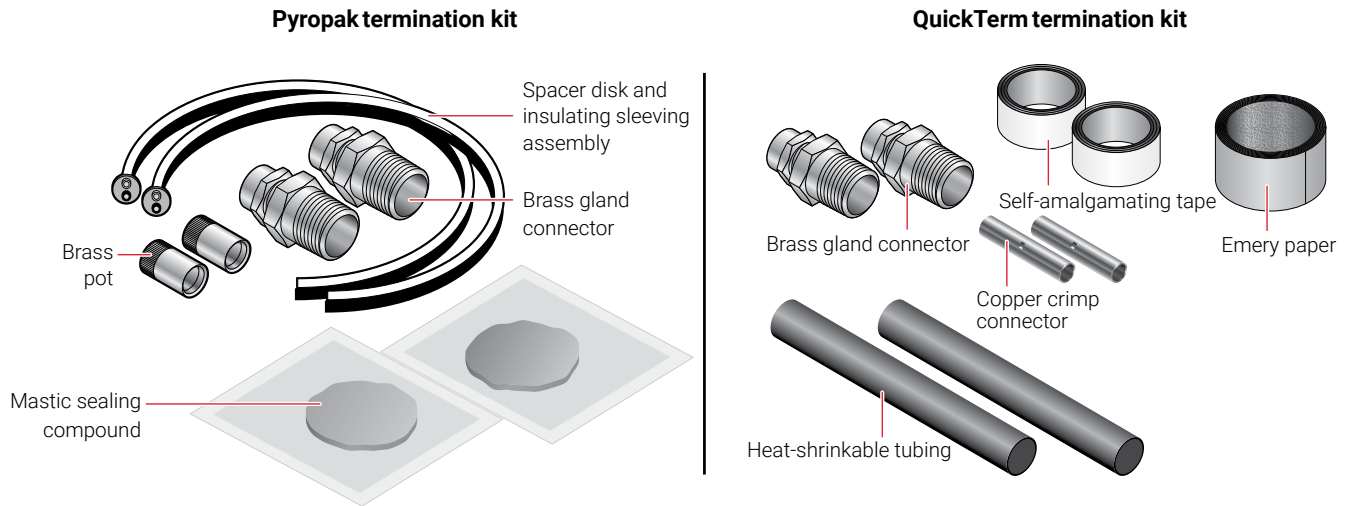

Fig. 9 Terminations for System 1850 MI cable

In cases where the manufactured length is shorter than the required run length, a splice is used to join individual lengths of cable. Two options for splicing System 1850 MI cable are available:

Factory fire-rated splice: A UL/ULC 2-hour fire-rated, all-welded joint is installed at the factory.

Field-installed fire-rated splice: A field-installed splice, consisting of a splice kit and a separate field installed fire protection kit, is used to extend cable length or to repair a damaged cable.

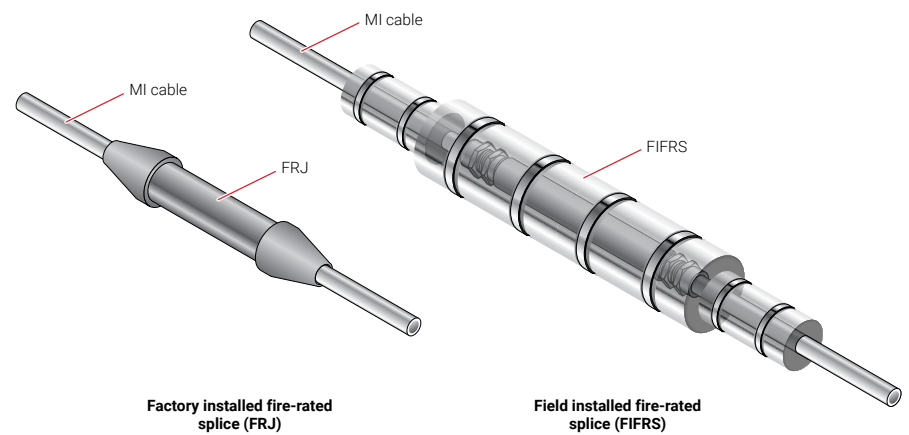

Fig. 10 Splices for System 1850 MI cable

Typical System Installation

A typical critical power circuit installation utilizing System 1850 MI cable is shown in Fig. 11. Additionally, components and accessories available for single and multiconductor MI cables are shown in Table 1. For further information on components and accessories, refer to the Components and Accessories data sheet, H57604.

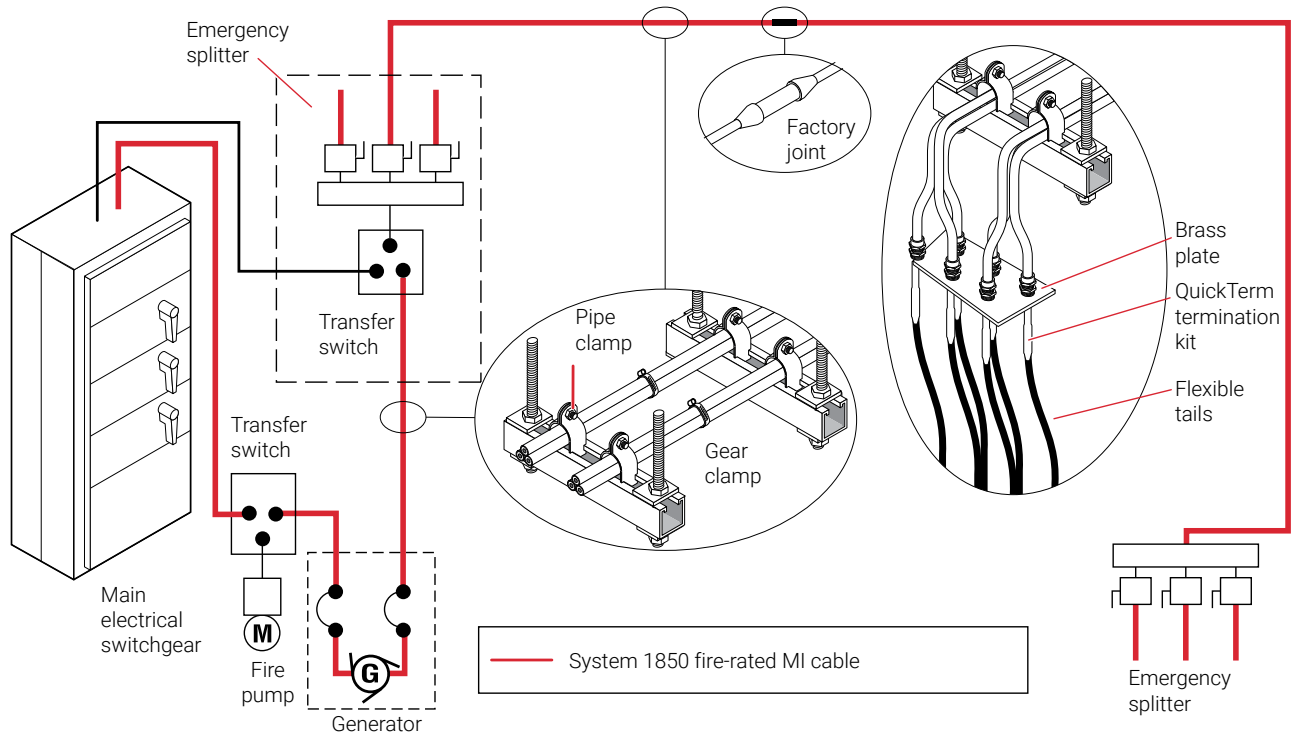

Fig. 11 Typical System 1850 power circuit system

TABLE 1 COMPONENT AND ACCESSORY AVAILABILITY

	Single conductor MI	Multiconductor MI
Pyropak termination kit	•	•
QuickTerm termination kit	•	•
Field and factory splices	•	•
Brass plates	•	•

INSTALLATION GUIDELINES

These installation guidelines apply to System 1850 MI cables only. When installing a system, refer to the requirements in the UL/ULC Fire Resistance Directory and System 1850 data sheet and installation instructions shipped with the product, and available on the nVent website at nVentthermal.com. Refer to national and local electrical codes for additional details. For further information, contact your nVent representative or call nVent at (800) 545-6258.

SUPPORTING SYSTEM 1850 MI CABLE

It is important that all support components are made of appropriate materials, such as copper, steel, stainless steel, and concrete. Low melting point or combustible materials such as aluminum, brass, plastic, lead, wood, etc. are not acceptable.

System 1850 MI cable may be directly mounted on noncombustible surfaces such as concrete or masonry, or supported by steel rod and channel (trapeze) systems. To achieve free air rating, spacing must be maintained between the cable bundles and also between the bundles and the mounting surface; refer to Fig. 12. UL/ULC listing requirements for fire-rated cables stipulate support spacing at certain intervals; refer to the installation instructions shipped with the product and available on the nVent website at nVentthermal.com.

System 1850 MI cable should not be installed in conduit, other than when transitioning through a wall, floor, or ceiling.

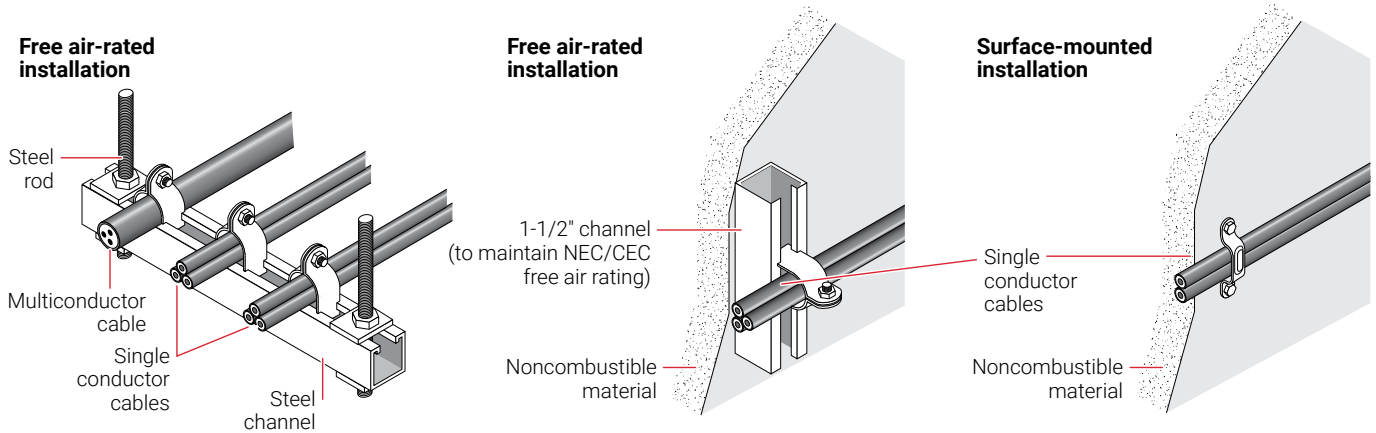

Fig. 12 Supporting System 1850 MI cable

It is important to keep the overall loading on the rod and channel system within limits. Table 2 shows the recommended loading guidelines based on the minimum channel depth of 1-1/2 inch. Note that the cable load calculations as shown in Table 2 take into account only the load represented by the MI cable.

TABLE 2 LOADING GUIDELINES

Cable load*	Support method
Up to 150 lbs (68 kg)	3/8" (10 mm) threaded rod
Between 150 lbs and 267 lbs (68 kg and 121 kg)	1/2" (13 mm) threaded rod
Between 267 lbs and 400 lbs (121 kg and 182 kg)	5/8" (16 mm) threaded rod
Channel	
1. Maximum width of 1-1/2 in (38 mm) channel: 36 in (915 mm)	
2. Maximum load per channel = 200 lbs (91 kg). Channel may be doubled to increase load to 400 lb (182 kg) or reduce spacing between supports ensuring that cable load does not exceed 200 lbs/channel.	
* Cable load (lbs) = lbs/ft cable x total number of runs x spacing between supports measured in feet Cable load (kg) = kg/m cable x total number of runs x spacing between supports measured in meters	

Note: UL/ULC listing requirements for fire-rated cables stipulate support spacing at certain intervals; refer to the installation instructions shipped with the product and available on the nVent website at nVentthermal.com.

SEISMIC CONSIDERATIONS

In areas where there is a risk of seismic activity, precautions must be taken where the cable crosses expansion joints and at termination points. For more information, refer to the document for MI Cable Expansion and Vibration, H57613.

CABLE LAYOUT

In multiconductor cables, the magnetic effects of the phase conductors cancel each other out, allowing for cable installation in any configuration. However, single conductor cables should be bundled in groups containing one conductor from each phase to minimize the resulting magnetic field in each grouping. The grouped single conductor cables are then fastened tightly together, ensuring that the gland connectors at each end of the cable run are connected to the metal enclosure through a nonferrous entry, such as a brass plate, or in accordance with national electrical codes. Typical single conductor cable configurations are shown in Fig. 13. The neutral conductor may be located within or outside the cable group.

	Single Phase	Three-Phase • 3 Wire	Three-Phase • 4 Wire
Single circuit (preferred)			
Single circuit (alternative)			
Two cables in parallel per phase (preferred)			
Two cables in parallel per phase (alternative)			
Three or more cables in parallel per phase (preferred)			
Three or more cables in parallel per phase (alternative)			

Note: For free air ampere ratings, the spacing "S" between bundles should be a minimum of 2.15 cable diameters in the U.S. (NEC) and Canada (CEC). For magnetic effect purposes, the neutral may be located as shown, or outside groups in the most convenient location.

Fig. 13 Recommended installation configurations

Electrical codes generally limit paralleling cable configurations to cable sizes 1/0 AWG and larger. The codes address the balancing of resistance by stipulating:

- All conductors must be the same length
- All conductors must be the same size and the same material
- All conductors must have the same type of insulation
- All conductors must be terminated in the same manner

A current measurement should be taken immediately after the cables begin to carry load. Load imbalances between conductors of up to 10% are tolerable and expected. Deviations above 10% must be investigated and corrected.

When installing single conductor cables through a ferrous enclosure, precautions must be taken to prevent induction heating in the steel. This is accomplished by removing a section of the enclosure and installing a nonferrous brass plate (in Canada, this is only required above 200 amperes). Brass plates with pretapped holes are available for the gland connectors.

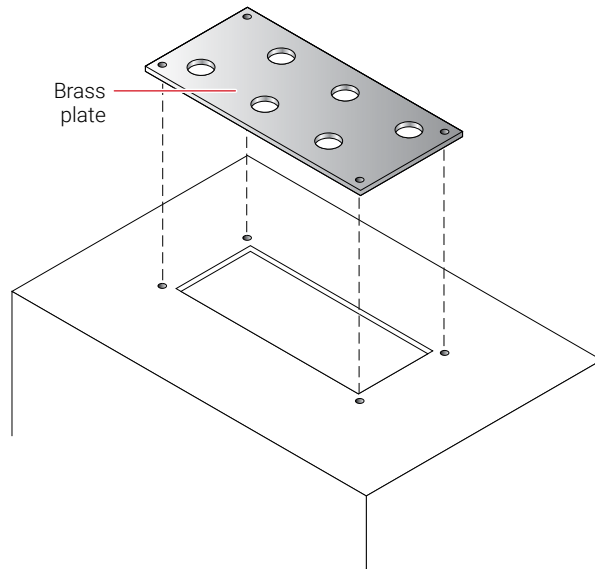

Fig. 14 Enclosure with cutout and brass plate

TERMINATING SYSTEM 1850 MI CABLE

Details on terminating System 1850 MI cables can be found in the installation instructions provided with each System 1850 MI cable termination kit.

Factory terminated System 1850 MI cable sets are available in a range of sizes and lengths. For details on terminated cable sets, contact your nVent representative or call nVent at (800) 545-6258.

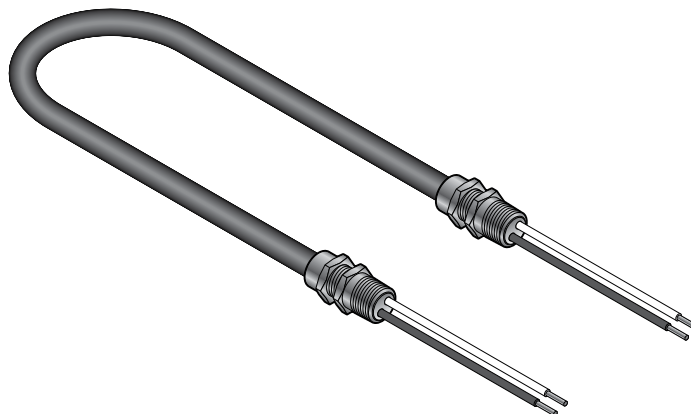

Fig. 15 Factory terminated System 1850 MI cable

CONNECTING SYSTEM 1850 MI CABLE

The termination gland is a brass fitting available in standard NPT sizes. The glands are supplied in 1/2", 3/4", 1", or 1-1/4" sizes, depending on the cable diameter.

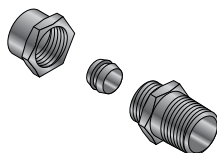

Fig. 16 Brass gland

Gland size information for each MI cable is available from the System 1850 data sheet, H57442 or System 1850Z data sheet (for polymer jacketed System 1850 cables), H59153. When tightened with the recommended torque, 25 ft-lbs for all gland sizes, this gland simultaneously seals the enclosure and grips the cable through a brass compression sleeve. This connection, when installed according to the installation instructions, provides the following benefits:

- Code-compliant bonding path from the cable sheath.
- Hydrostatic withstand pressure up to 500 lbs/in² (35 kg/cm²)



Note: Terminations are not required to be fire-rated since the emergency equipment they serve is in a fire-rated room.

North America

Tel +1.800.545.6258
Fax +1.800.527.5703
thermal.info@nvent.com

Europe, Middle East, Africa

Tel +32.16.213.511
Fax +32.16.213.604
thermal.info@nvent.com

Asia Pacific

Tel +86.21.2412.1688
Fax +86.21.5426.3167
cn.thermal.info@nvent.com

Latin America

Tel +1.713.868.4800
Fax +1.713.868.2333
thermal.info@nvent.com



Our powerful portfolio of brands:

CADDY ERICO HOFFMAN RAYCHEM SCHROFF TRACER