

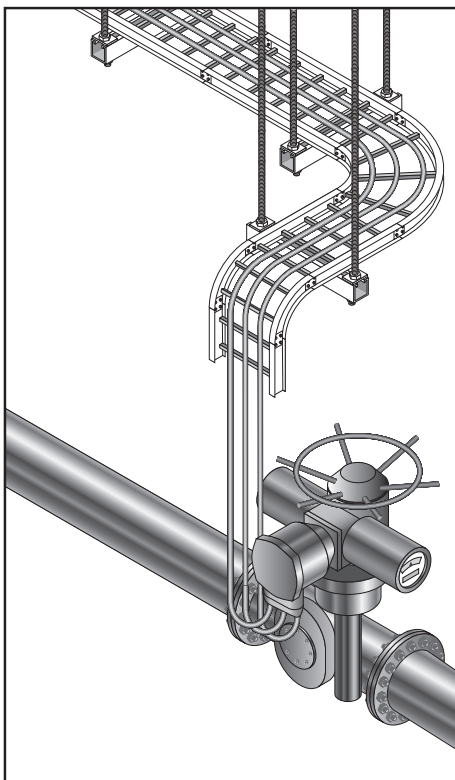

**PYROTENAX**

# Industrial MI Wiring Cable

Installation Manual for Alloy 825 Sheath Cable  
Wiring Systems



## Important Safeguards and Warnings

### **WARNING: FIRE AND SHOCK HAZARD.**

nVent PYROTENAX mineral insulated (MI) industrial wiring cables must be installed in accordance with the requirements of national and local codes and standards, the installation instructions in this manual, and the customer's specification. Read these important safeguards and carefully follow the installation instructions.

- Ensure the cable has been stored properly and is in good condition prior to commencing installation.
- Always use safe working practices when installing cables, observing OSHA and other national safety rules.
- Store cables indoors in a clean, dry, covered area, if possible.
- During the time that the cables are exposed and during cable pulling activities, protect cables from nearby or overhead work to prevent damage to the cable sheath.
- Do not pull cables around corners that have sharp edges, such as corners in cable trays, or other obstructions.
- Prevent damage to cables by removing any abrasions or sharp edges from surface of support system.
- Damage to cables or components can cause sustained electrical arcing or fire. Do not energize cables that have been damaged. Damaged cable or terminations may need to be repaired or replaced. Damaged cable should be repaired by a qualified person.
- When installing cables which may be exposed to hydrocarbon flash fires, use only steel or stainless steel in the support system.

# Table of Contents

---

<b>1</b>	<b>General Information</b>	<b>1</b>
	1.1 Use of the Manual	1
	1.2 Safety Guidelines	1
	1.3 Approvals	2
	1.4 Warranty	2
<b>2</b>	<b>Introduction</b>	<b>3</b>
	2.1 General	3
	2.2 Factory Terminated Cables	4
	2.3 Field Terminated Cables	4
<b>3</b>	<b>Storage and Handling</b>	<b>5</b>
	3.1 Storage	5
	3.2 Handling	7
<b>4</b>	<b>Pre-Installation</b>	<b>11</b>
	4.1 Minimum Installation Temperature	11
	4.2 Precautions	11
	4.3 Factory Terminated Cables	12
	4.4 Installation Equipment	12
	4.5 Set-Up	13
<b>5</b>	<b>Installation</b>	<b>15</b>
	5.1 General Installation Guidelines	15
	5.2 Connection to Junction Boxes and Other Equipment	25
	5.3 Installation in Hazardous Areas	27
	5.4 Protecting the MI Cable Terminations from Hydrocarbon Flash Fires	29
	5.5 Cable Terminations	31
<b>6</b>	<b>Testing and Commissioning</b>	<b>33</b>
	6.1 Tests	33
<b>7</b>	<b>Troubleshooting Guide</b>	<b>38</b>
<b>8</b>	<b>Appendixes</b>	<b>40</b>
	Appendix A: Improving Insulation Resistance (IR)	40
	Appendix B: Cable Inspection Record	42



# 1

## General Information

---

### 1.1 Use of the Manual

This manual covers storage and installation of nVent PYROTENAX Alloy 825 Sheath MI industrial wiring cables. It is assumed that the cables have been correctly sized and the installation properly designed. Installers must be trained and familiar with relevant codes and standards and generally accepted good practice for handling and installing power cables. For installations or situations that are not covered in this guide, please contact nVent for guidance.

For additional information, contact:

**nVent**

7433 Harwin Drive  
Houston, TX 77036  
USA



Tel: +1.800.545.6258  
Fax: +1.800.527.5703  
thermal.info@nVent.com  
**nVent.com**

### 1.2 Safety Guidelines

The safety and reliability of an MI cable system depends on the proper design and installation of the system and use of proper materials for support, as well as the quality of the cable selected. Incorrect design or installation or use of inappropriate support materials can result in a system that may not perform satisfactorily, and in the case of a fire-rated system, it may not perform under fire conditions.

Install all wiring in accordance with the latest edition of national electrical codes and standards, such as the National Electrical Code (NEC) or Canadian Electrical Code (CEC), and/or the Authority Having Jurisdiction and the instructions in this manual.

Pay special attention to the following:

- Important instructions are marked  **Important**
- Warnings are marked  **WARNING**

# 1

## General Information

---

### 1.3 Approvals

MI industrial wiring cables are manufactured in accordance with international standards.

- Factory terminated cables are: cCSAus Certified
- Bulk cable is: cULus Listed and cCSAus Certified
- Field installed termination kits for bulk cable are: cCSAus Certified



**Important: ATEX certified terminations also available.**

### 1.4 Warranty

MI industrial wiring products Limited Warranty applies to these products. For details, see the complete warranty on our web site at [nVent.com](http://nVent.com).



**Important: For the nVent warranty and agency approvals to apply, the instructions that are included in this manual and product packages must be followed.**

# 2

## Introduction

### 2.1

#### General

MI industrial wiring cable is manufactured with nickel-clad copper or nickel conductors within a robust Alloy 825 sheath, embedded in highly compacted magnesium oxide insulation (Figure 1). This construction and the nature of the inorganic materials used provide MI cables with characteristics that surpass those of other cable types without the need for additional protection such as conduit. One of the most exceptional qualities of MI cable is its fire resistance—the cable will not burn, support combustion, propagate flame, or emit smoke or toxic gases.

MI cable can be used for indoor and outdoor applications in industrial installations. It is extensively used in petrochemical plants where the integrity of power and control wiring to emergency block valves and emergency equipment must be maintained during a hydrocarbon flash fire. The solid construction of MI cable makes it suitable for use in hazardous areas to prevent the passage of explosive gases. In addition, it is used in pulp and paper plants, electricity generation plants, and in mines and manufacturing where resistance to extreme heat and corrosion is required. For further information on using and installing MI cable, refer to the applicable sections of the NEC / CEC or other national electrical codes and standards if outside the US and Canada.

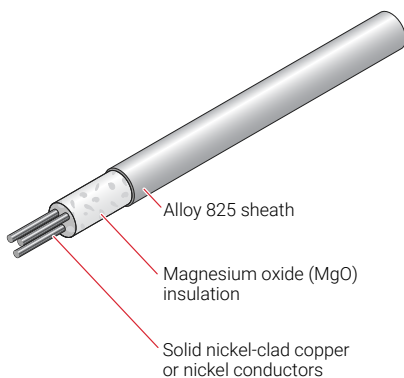

**Figure 1: MI industrial wiring cable**

# 2

## Introduction

---

### 2.2 **Factory Terminated Cables**

Factory terminated cables can be connected as received to junction boxes and other equipment. The standard factory termination utilizes the epoxy sealing compound shown in Figure 22. The cables are supplied with a metal identification tag showing the cable specifications and approvals.

### 2.3 **Field Terminated Cables**

Cables that are to be terminated in the field are supplied with temporary heat shrinkable end caps that seal the ends against moisture ingress. Field installed termination kits are available with the epoxy sealing compound or mastic sealing compound shown in Section 5.5 and should be selected based on the application. Identification tags are not supplied.



# 3

## Storage and Handling

---

The rugged construction of MI industrial wiring cable makes it the perfect solution for all industrial applications, no matter how extreme. However, certain storage and handling guidelines should be followed to minimize the possibility of damage to the cable.

### 3.1 Storage

To protect cables from physical damage and the environment, inspect the cables upon receipt and observe the following storage measures.

#### Initial Inspection

When the cables are received:

- Inspect the factory-applied protective covering on the cable for evidence of shipment damage. Keep the protective cover in place until removal is absolutely necessary.
- Where possible, check the cable sheath for evidence of shipment damage.
- Verify that terminations or heat shrinkable end caps are not damaged, missing, or removed.
- Verify that factory terminated cables are correctly labeled and have the appropriate gland connector fittings for the intended use.
- Check the insulation resistance (IR) for the presence of moisture in the cable using a megohmmeter (damage to the sheath, end caps, or terminations will cause moisture to enter the cable). See Section 6 for testing guidelines and record the results of the tests in the Cable Inspection Record in Appendix B. If moisture is present, follow the instructions in Appendix A to remove the moisture or contact nVent for guidance.

# 3

## Storage and Handling

### Storage Measures

- Store all cables indoors in a clean, dry location, if possible, and protect from moisture, construction equipment, falling objects, chemical spills, moving vehicles, and other hazards.
- Store factory terminated cables in a manner that prevents damage to the sealing pot and flexible tails.
- Do not remove the heat shrinkable end caps from bulk cable until the cable is ready to be terminated.
- Do not stack coils or reels.
- Do not store coils or reels flat. Store coils upright and reels upright on their flanges (Figure 2).
- Ensure that both ends of the cable are securely fastened to the reel flange.
- Store reels on a firm surface, paved if possible, or on planking to prevent reels from rotting.

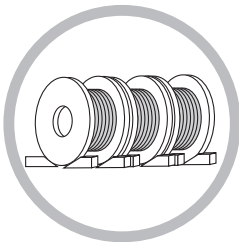

Always load and store reels upright on their flanges and block securely.

**Right**



Laying heavy reels flat can cause damage.

**Wrong**

**Figure 2: Store reels upright on flanges**

# 3

## Storage and Handling

---

### 3.2 Handling

#### Moving Coils and Reels

- Handle and install cables within suitable temperature limits (See Section 4.1).
- Handle coils and reels utilizing equipment designed for that purpose.
- Do not drop coils or reels from any height, particularly from trucks or other transporting equipment.
- Lift or handle coils and cable reels in such a manner that the lifting / handling device does not make direct contact with the cable or its protective covering. Coils should be placed on a skid.
- Handle reels in a manner that prevents deterioration of and physical damage to the reel and to the cable.
- Take precautions to ensure that the flange of one reel does not impact the cable on another reel.



**Important: If a coil or reel is dropped or the protective covering is damaged, examine the cable for damage. Refer to Section 7 for the Troubleshooting Guide. Damaged cables may need to be repaired or replaced. Contact your local representative for more information.**

The following lifting methods for reels are recommended (Figure 3):

- Insert a suitable properly-secured shaft through the reel arbor hole and lift with slings using a crane or boom- type equipment. Use a spreader or other device to minimize sling pressure against the reel flange.
- Move smaller, narrower reels using a forklift. Place fork tines so that lifting pressure is on both reel flanges, not on the cable.

# 3

## Storage and Handling

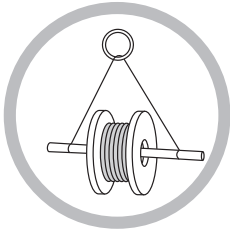

Reels can be hoisted with a properly secured shaft extending through both flanges.



Do not lift by a single reel flange. Cable or reel may be damaged.

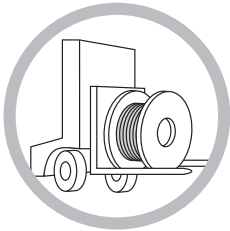

Cradle both reel flanges between fork tines.



Never allow fork tines to touch the cable surface or reel wrap.

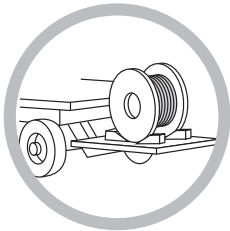

Lower reels from a truck using a hydraulic gate, hoist or fork lift. **LOWER CAREFULLY.**

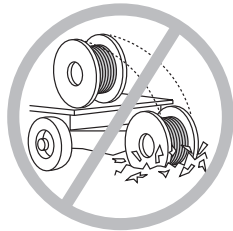

Never drop reels.

**Right**

**Wrong**

**Figure 3: Reel handling DOs and DON'Ts**

# 3

## Storage and Handling

- Roll reels to move them short distances and in the direction so that the cable does not unwind (Figure 4); this will tighten the cable windings, not loosen them. It is recommended that surfaces over which the reels are rolled be firm, level, and clear of debris that may damage the cable.

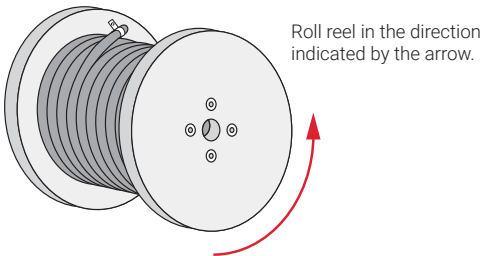

**Figure 4: Reel rolling**

### Uncoiling Cable

- Do not uncoil cable or transfer cable to another reel prior to installation as it will become work hardened, making it less easy to install.
- Support reel on a jack stand when uncoiling; cables supplied in coils may be fed from a pay-off reel (Figure 5). Have someone rotate the reel or coil to feed the cable as it is being pulled. This will greatly ease the handling and prevent possible twisting, bending, and kinking.
- Use appropriate precautions when uncoiling cable (see Section 4.2).
- Handle cable carefully during uncoiling to prevent damage due to kinking, or bending to a radius smaller than the minimum pulling radius (see Table 2).
- Ensure that the cable is not twisted during installation.
- Do not run over cable, drag cable over sharp objects, or subject cable to other such treatment that could cause damage.

# 3

## Storage and Handling

---

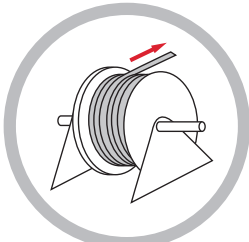

Right

Reel



Wrong

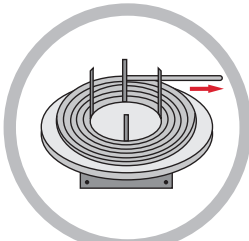

Right

Coil



Wrong

Figure 5: Unreeeling / uncoiling cable

# 4

## Pre-Installation

---

Cable installations must be preplanned to ensure a successful installation. It is important to ensure that personnel are properly trained and qualified for the specific task they are performing. All applicable rules and regulations including federal, state / provincial, local, and municipal laws must be followed. For further information on installing MI cables, contact nVent Technical Support, see Section 1.1.

### 4.1 Minimum Installation Temperature

A minimum installation temperature of  $-40^{\circ}\text{F}$  ( $-40^{\circ}\text{C}$ ) is recommended for MI cables.

### 4.2 Precautions

When installing MI industrial wiring cables, all appropriate precautions should be followed, including OSHA and other applicable national safety regulations. Therefore, in addition to observing standard safety practices, observe the following:

- Take reasonable precautions to prevent damage to the cable from severe blows with sharp instruments and pulling over sharp objects.
- Do not pull cables around corners that have sharp edges, such as corners in cable trays, or other obstructions.
- Pull all cable diameters, one at a time, by hand.
- Hand feed cables around corners using large sweeping bends.
- When changing direction from horizontal to vertical, use properly-sized sheaves or pulleys.
- Protect exposed cables from any nearby or overhead work that could damage the cable.
- Do not pull cables around a radius smaller than the minimum pulling radius (see Table 2).
- Make sure all equipment used during cable installation is in good operating condition.

For further assistance on pulling cables, contact nVent Technical Support, see Section 1.1.

# 4

## Pre-Installation

### 4.3 Factory Terminated Cables

Prior to installation of long runs of cable, attach a short length of PVC conduit to the factory terminated ends to provide protection for the sealing pot and flexible tails (Figure 6). Use 1 in (25 mm) minimum PVC pipe, or larger if a 1 in or 1-1/4 in (25 mm or 32 mm) gland connector is supplied. This will prevent damage to the sealing pot and tails during installation.

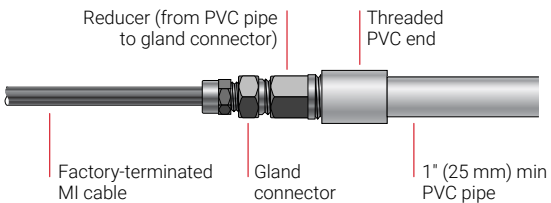

**Figure 6: Protecting sealing pot and flexible tails**

### 4.4 Installation Equipment

#### Pulling Equipment

It is recommended that all sizes of cables be hand pulled into position, one at a time, using pulling ropes securely attached to the cable end. When pulling cables around corners, hand feed cables using large sweeping bends. Mechanical pulling equipment, such as tuggers, is not recommended.

#### Sheaves

Use sheaves or pulleys of the proper diameter, where required, to avoid damage to the cable.

#### Pulling Rope

Use non-stretch pulling rope with a capacity large enough to handle the force required to pull the cable.

It is recommended that the pulling rope be attached to the cable sheath using a series of six half-hitch knots, and the knots and rope be securely taped to the sheath to prevent movement during the pull.



# 4

## Pre-Installation

---

When pulling cables from a factory terminated end, ensure that the end is protected with a short length of PVC pipe (see Figure 6) and securely attach the pulling rope to the cable sheath to avoid damage to the termination.

Install cable grips, swivels, and pulling eyes, if used, according to manufacturer's instructions.

### 4.5 Set-Up

Examine cable trays, trapeze support systems, and other support systems for acceptability prior to pulling activities. Install permanent supports properly to ensure the rigidity of the cable tray, trapeze, or other support system so that neither the support system nor the cable will be subjected to damage during the pulling process.

Before installation, verify that the cable(s) can be installed according to the designed routing and minimum bending radius requirements.

Where it is not practical to completely remove the cable from the reel, set up the reel using sheaves or pulleys as shown in Figure 7. The first sheave must be installed at a point higher than the support system. Use a roller at the entry and exit points of the tray / trapeze system. The setup should ensure that the cable is not kinked or bent beyond the minimum pulling radius (see Table 2) or subject to excessive twisting force.

Minimize the amount of tension necessary to pull a cable as follows:

- Pull in the proper direction. Where practical, a cable pull should begin nearest the end having the least degrees of bends and exit the end having the greater degrees of bends if at all possible. Also, in vertical sections, an upward pull is preferred.
- Minimize the number and degrees of bends the cable is pulled around under tension. Accomplish this by finding the straightest route possible using the least amount of bends.

# 4

## Pre-Installation

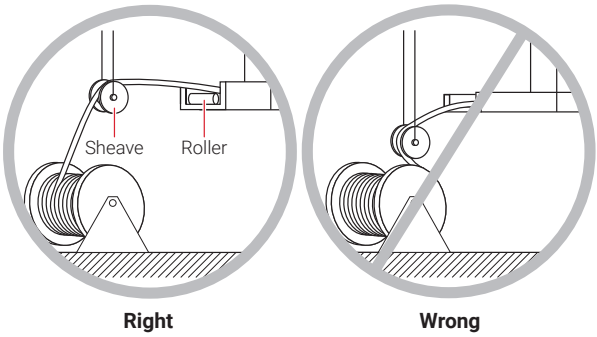

**Figure 7: Reel set-up**

Station experienced cable pulling observers along the route, in contact (visually, by radio, or by phone) with the other members of the crew.

# 5

## Installation

---

Following these installation instructions will consistently produce satisfactory MI cable installations. Further information on proper installation techniques may be obtained by contacting nVent Technical Support (See Section 1.1).

### 5.1 General Installation Guidelines

- When subject to potentially damaging abuse, protect the cable with a metal guard such as angle iron or steel channel.
- Metal supports, cable sheath, and other metal enclosures for the cables must be metallically joined together and must be connected to all boxes, fittings, and cabinets so as to provide effective electrical continuity.
- Ensure that you do not invalidate the listing of enclosures or other equipment if it is necessary to cut holes.

#### **Moisture Absorption**

The magnesium oxide insulation of MI cable is hygroscopic and can absorb moisture when exposed to air, causing the IR to fall. Low IR can be corrected as outlined in Appendix A.

#### **Expansion and Vibration**

Where cables may expand or contract due to temperature changes, or when connecting the cable to vibrating equipment, it may be necessary to take precautions to prevent mechanical damage to MI cable. Refer to Sections 5.2 and 5.3 for further details.

#### **Equipment Bonding**

The sheath of Alloy 825 MI cable must be bonded to ground, but must not be used as the equipment-to-ground bonding conductor. For proper equipment-to-ground bonding, use one conductor within the sheath or use a separate equipment-to-ground bonding conductor.

# 5

## Installation

### **Straightening and Dressing the Cable**

The cable may be straightened by hand or by using a dead blow hammer and a block of wood as shown in Figure 8. Do not use a metal hammer as it may result in unsightly dents that cannot be removed. Once the cable has been installed, the use of stainless steel banding or cable clamps to strap the cable to the tray will help dress the cable, maintaining a neat appearance.

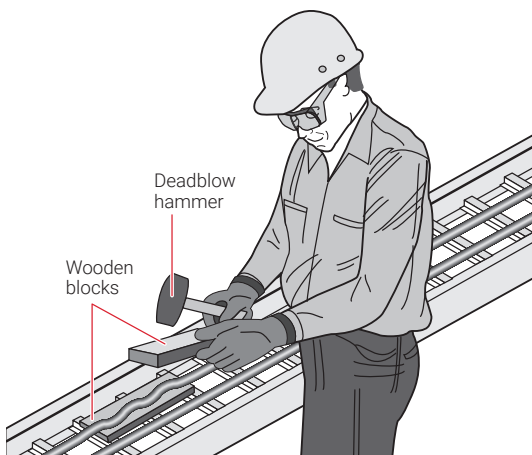

**Figure 8: Straightening and dressing MI cable**

### **Bending Radius**

The minimum bending radius for permanent training of MI cable is shown in Table 1, although it is recommended that bends are kept as large as possible. Where smaller bends are necessary, a conduit bending tool (Figure 9) may be utilized, but care must be taken not to bend the cables to less than the minimum bending radius.

# 5

## Installation

**TABLE 1: MINIMUM BENDING RADIUS FOR PERMANENT TRAINING**

Cable O.D. (outside diameter)	
0.75 in (19 mm) and smaller	6 times cable diameter
Larger than 0.75 in (19 mm)	12 times cable diameter

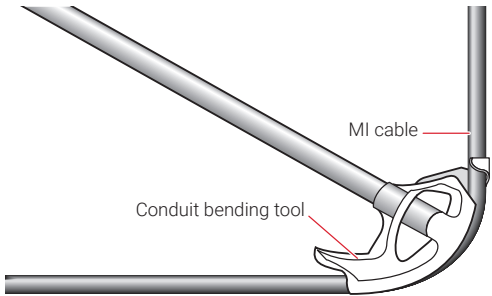
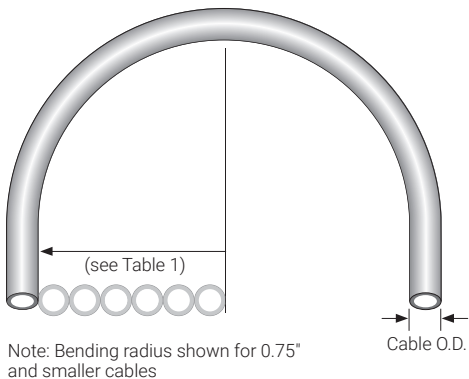

**Figure 9: Use conduit bending tool for smaller bends**

The relationship between cable diameter and minimum bending radius is shown in Figure 10. When small bends are necessary, do not try to make the entire bend in one operation. Bend in small increments. Shape into final position gradually. When offsetting the cable to enter a junction box / equipment via a gland connector, at least 2 to 3 in (50 to 75 mm) of straight cable should be left between the gland connector and the final bend to facilitate withdrawal of the gland connector from the junction box / equipment.

# 5

## Installation



**Figure 10: Minimum bending radius**

### **Pulling the Cable into Position**

For ease of installation, it is recommended that the cables be completely uncoiled, or removed from the reel, and laid out in a straight run with the end to be pulled closest to the entry point into the support system (cable tray, trapeze, etc.). Attach the pulling rope to the end of the cable as described in Section 4.4.

Pull the cable by hand throughout the desired routing. Use personnel to guide the cable around corners using large sweeping hand-formed bends. Do not bend the cable to a radius smaller than the minimum pulling radius shown in Table 2 while pulling the cable into position. When changing direction from a horizontal to vertical pull, use sheaves or pulleys to guide the cable around the bend. The cable can be neatly arranged in the tray / trapeze once it has been completely pulled into position.

If installing a cable with a factory termination on one end only, and if space permits, it is recommended that the cable pull begin at the equipment, such as a valve actuator, and that the cable be pulled from the unterminated end. This will reduce the possibility of damage to the terminated end.

# 5

## Installation

**TABLE 2: MINIMUM PULLING RADIUS**

<b>Cable O.D. (outside diameter)</b>	
0.75 in (19 mm) and smaller	12 times cable diameter
Larger than 0.75 in (19 mm)	24 times cable diameter

### **Multiconductor Cable**

Multiconductor cables are typically used in industrial wiring applications. Cables can be connected to any junction box, valve actuator, or equipment approved for the area classification. Refer to Sections 5.2, 5.3 and 5.4 for further details on connecting MI multiconductor cables to junction boxes and other equipment, and be sure to follow the applicable requirements of the NEC / CEC, or other national electrical codes and standards.

### **Twisted Pair Fire Alarm and Communication Cable**

Twisted pair cable is installed in the same manner as multiconductor cables. When installing circuits requiring twisted pair cables, ensure that the cable parameters are compatible with the equipment.

### **Single Conductor Cable**

Cables may be run in triplex or quadruplex (includes a neutral), or alternatively, side-by-side configuration. The triplex / quadruplex configuration is recommended for best sheath current cancellation.

When single conductor cables enter a ferrous metal enclosure, precautions must be taken to prevent heating by induction. It is recommended that the cables be connected to nonmagnetic stainless steel junction boxes and enclosures. For further information on terminating single conductor cables, contact nVent Technical Support, see Section 1.1.

All conductors of the same circuit, and where used, the grounded conductor (neutral) and all conductors bonding equipment to ground, must be contained within the same cable tray or bundled with the cables within a trapeze system or equivalent, unless otherwise permitted

# 5

## Installation

---

in accordance with the NEC / CEC or other national electrical codes and standards. These requirements apply separately to parallel circuits.

Conductors to be joined in parallel should follow the applicable sections of the NEC / CEC or other national electrical codes and standards. Multiple circuits should be appropriately spaced for ampacity considerations. Where independent circuits are required or desired, maintain proper separation and segregation from other electrical circuits.

Bundle single conductor MI cables tightly together every 2 ft (610 mm) along the entire length of cable run, in groups containing one conductor per phase, the neutral (if used), and the equipment-to-ground bonding conductor using stainless steel banding or stainless steel adjustable gear clamps. This maintains the cable sheaths in contact throughout the length of the run, which minimizes sheath currents and stabilizes the cables under short circuit and fire conditions. Where parallel runs are required, cable bundles must be spaced apart 2.15 cable diameters in USA and Canada. Follow the applicable requirements of the NEC / CEC, or other national electrical codes and standards.

### **Exposed or Surface Installations**

The components used to support the cables throughout the run must be made of steel or stainless steel. In areas where the cables may be exposed to hydrocarbon flash fires, the support system components must be in compliance with UL1709, the Rapid Rise Fire Tests of Protection Materials for Structural Steel. The support system component material should be selected based on the environment in which it is installed, as it may have to withstand the high temperatures possible in a hydrocarbon flash fire and / or the harmful effects of corrosive areas. Ensure that the materials used to support the cables are compatible with the cable sheath.



**Important: For fire-rated installations, do not use material such as aluminum, brass, copper, plastic, lead, wood, etc., since these materials will fail quickly during a fire.**



# 5

## Installation

---

The support system must provide strength and working load capabilities to meet the load requirement of the wiring system. Support the cables on horizontal and vertical runs at the spacing requirements in the NEC / CEC, other national electrical codes and standards, or per customer's specifications. Pay special attention to fire-rated installations as it may be necessary to use support spacing closer than that specified in the NEC / CEC or other national electrical codes and standards.

Several support methods may be used; however, cable tray is recommended due to its wide availability and familiarity among installing contractors.

### **Cable Tray**

Figure 11 and Figure 12 show two typical cable tray installation methods using open ladder, trough-type tray. In Figure 11, the cable tray is supported using a rod and channel trapeze type system. In Figure 12, the tray is supported using steel I-beams. Follow the cable tray manufacturer's installation instructions to install the tray.

Complete the cable tray installation before installing the MI cables. Metallic cable tray systems must be electrically continuous and effectively bonded as per the requirements of the NEC / CEC or other national electrical codes and standards.

Install cables so that the sheaths are in good electrical contact with the tray. **Do not overload the cable tray**; follow the loading requirements in the NEC / CEC or other national electrical codes and standards when installing cables in cable tray. Refer to "Single Conductor Cable" on page 19 and "Multiconductor Cable" on page 19 for details regarding the installation of single and multiconductor MI industrial wiring cables.

Allow extra cable to form several service loops along the cable run, if possible. Band together the cable forming the loops using stainless steel adjustable gear clamps or tie wire. Keep the diameter of the loops as large as practically possible. During future maintenance,

# 5

## Installation

replacement, or relocation of equipment, the extra cable can be used to service or rewire the equipment without having to replace the cable.

Once the cables have been pulled into position, secure the cables to the rungs of the cable tray every 2 ft (610 mm) using stainless steel bands, stainless steel tie wire, or adjustable gear clamps. This ensures a neat installation, prevents movement of the cables, and is particularly important in the case of vertical runs of cable as it prevents the top section of cable from supporting the weight of the entire vertical cable run.

For further information on cable tray installations, contact nVent Technical Support, see Section 1.1.

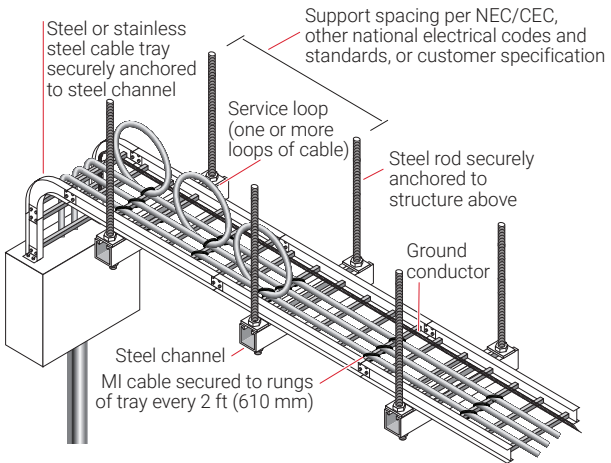

**Figure 11: Typical cable tray installation using trapeze supports**

# 5

## Installation

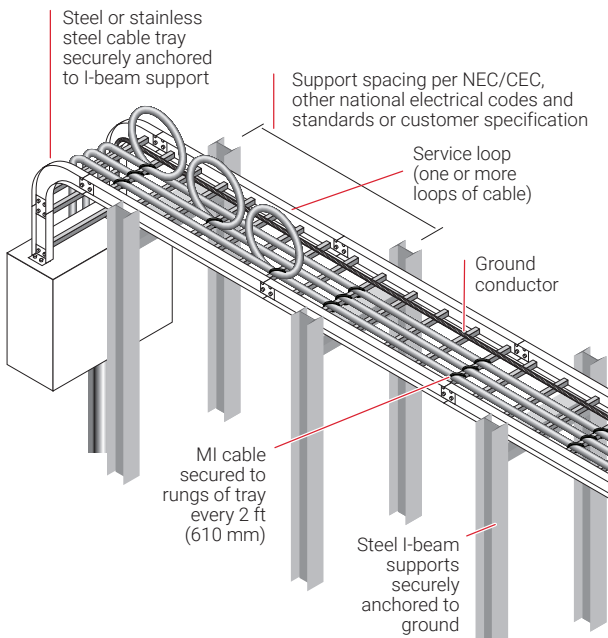

**Figure 12: Typical cable tray installation using steel I-beam supports**

### Trapeze Support

A typical trapeze system installation is shown in Figure 13. Follow the trapeze system manufacturer's installation instructions to properly install the trapeze system.

The trapeze system does not readily allow placement of service loops (Figure 11 and Figure 12). If service loops are required for future maintenance, replacement, or relocation of equipment, install the cables in cable tray.

Complete the trapeze system installation before installing the MI cables. **Do not overload the trapeze system**; under fire conditions, the steel channel will sag (deflect) possibly damaging the cables. Refer to "Single Conductor Cable" on page 19 and "Multiconductor Cable" on page 19 for details regarding the installation of single and multiconductor MI industrial wiring cables.

# 5

## Installation

Once the cables have been pulled into position, secure cables to the channel with steel or stainless steel single bolt pipe clamps sized to correspond with the outside diameter of the cable or cable bundle. This ensures a neat installation, prevents movement of the cables, and is particularly important in the case of vertical runs of cable as it prevents the top section of cable from supporting the weight of the entire vertical cable run.

For further information on this installation method, contact nVent Technical Support, see Section 1.1.

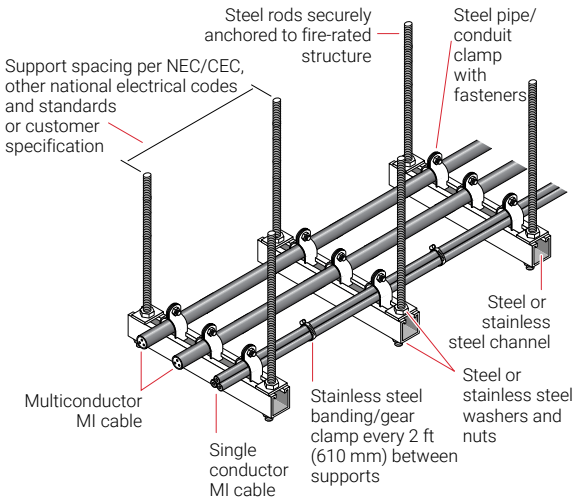

**Figure 13: Typical installation using trapeze support**

# 5

## Installation

### 5.2 Connection to Junction Boxes and Other Equipment

Locating junction boxes below grade or too low to the ground may allow moisture to enter the junction box, resulting in cable failure. All junction boxes must be mounted above grade level.

All cable or conduit leading to junction boxes must be installed so that water does not enter the box. Avoid entering the junction box from the top as this may allow water to enter. Take appropriate measures to ensure that moisture does not collect in the bottom of the junction box.

Connect the MI cable to junction boxes, motors, or other equipment suitable for the area classification (hazardous or nonhazardous) and environmental conditions (corrosive, wet, etc.) expected. Metal junction boxes are recommended because the cable sheath can be bonded to ground, through the gland connector, to the junction box. If using nonmetallic junction boxes, the gland connector must be connected to a ground bushing (Figure 14) to ensure that the cable sheath is bonded to ground.

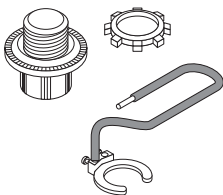

**Figure 14: Typical ground bushing (for nonmetallic enclosures only)**

Install the “pot” so that it extends above the bottom of the junction box (Figure 15 and Figure 16) to prevent moisture, due to condensation, from contaminating the face of the pot. Screw the gland connector into the junction box hub and tighten the compression nut (rear nut on gland connector) to the torque value shown on the tag supplied with the factory terminated cable or field termination kit. This ensures that the cable

# 5

## Installation

sheath is properly bonded to ground and provides a proper flame path in hazardous areas.

 **Important: Minimize handling the tails to avoid breakage.**

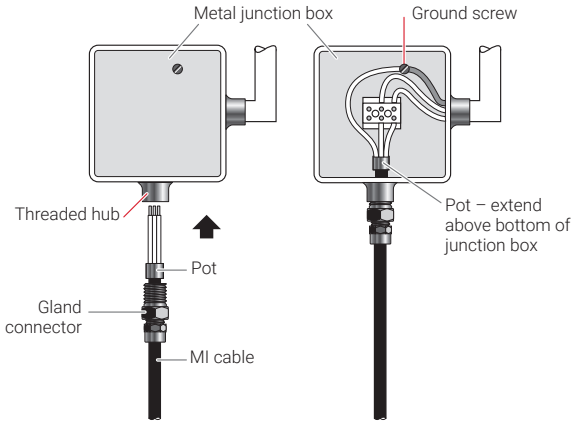

**Figure 15: Connection to metal junction box**

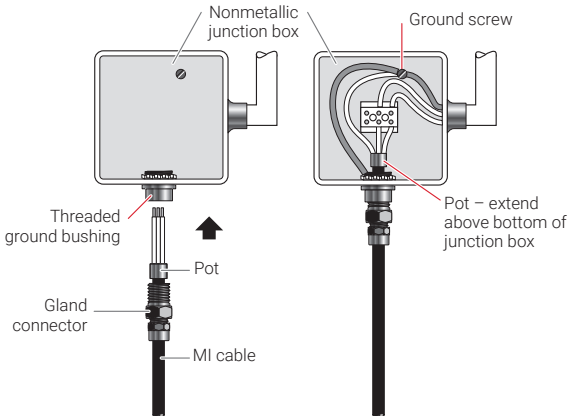

**Figure 16: Connection to nonmetallic junction box**

# 5

## Installation

In outdoor locations, form a large “U” shaped drip loop (Figure 17) or a large drip / expansion loop (Figure 18) at the points of entry into junction boxes and other equipment. This prevents moisture, which may track along the cable sheath and collect around the entry point, from entering the junction box through the hub.

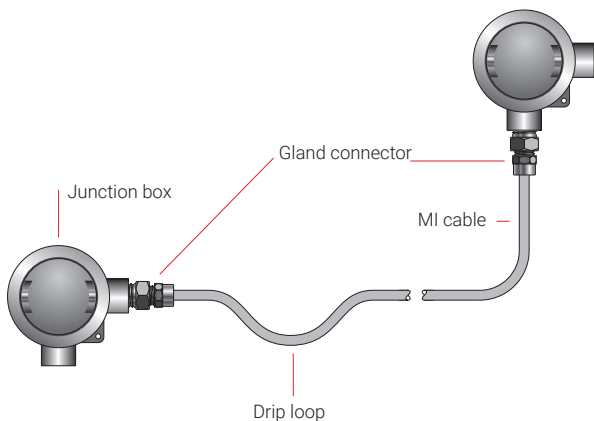

Figure 17: Drip loop at point of entry into junction box

### 5.3 Installation in Hazardous Areas

Due to the solid construction of MI cable, exploding gases or vapors and liquids under continuous pressure cannot travel through it. When terminated with an approved termination for hazardous areas, MI cable is a proven gas path block and is used for wiring to equipment and junction boxes in hazardous areas without the requirement for conduit and special seals.

MI cable can be used in place of braided flexible couplings in areas where limited flexibility is needed. Where the termination is subjected to vibration, such as when connecting to a motor, a large expansion loop as shown in Figure 18 is recommended. In cases of severe differential vibration, the cable should be terminated into a junction box adjacent to the vibrating equipment and the final connection made via a flexible conduit and / or cable.

# 5

## Installation

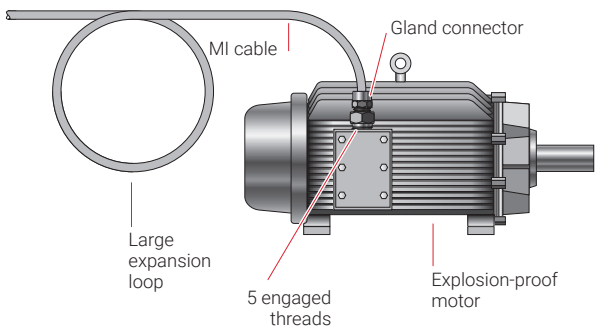

**Figure 18: Expansion loop at cable end to absorb vibration**

To connect MI cable to a junction box, motor, or other equipment approved for use in hazardous areas, screw the gland connector into the threaded hub and tighten to the recommended torque. If making a field termination, ensure that the termination kit is the correct type for the area classification (see Figure 22 and Figure 23). Use up excess cable by forming the cable into a loop as shown in Figure 19. All installations must be in compliance with the applicable requirements of the NEC / CEC and any other applicable national or local codes and standards.



# 5

## Installation

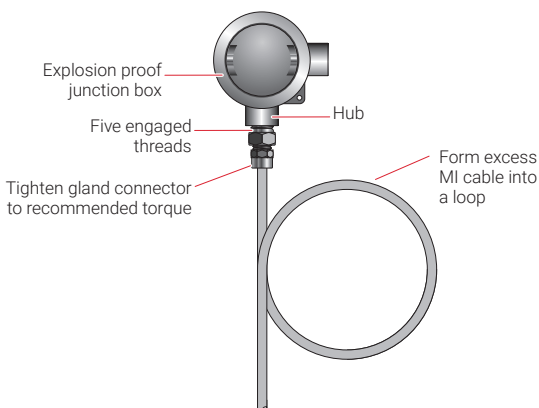



Figure 19: MI cable connection into junction box

### 5.4 Protecting the MI Cable Terminations from Hydrocarbon Flash Fires

While MI cable will continue to function when subjected to fire, the terminations must be protected from the fire. To maintain the functionality of the terminations in installations where they may be exposed to a hydrocarbon flash fire, protect the terminations with a passive fireproofing system, such as a rigid / semi-rigid enclosure, flexible enclosure, or intumescent coating (such as K-MASS) capable of withstanding the expected temperatures. For other fire-rated applications where the terminations must be protected, please contact nVent Technical Support, see Section 1.1.

 **Important: Junction boxes, actuators, valves, etc. must be protected as required by the customer specification.**

In Figure 20 and Figure 21 the junction box and valve actuator are in the fire zone and are protected with intumescent fireproofing material. In both cases, the MI cable gland connectors (terminations) must be protected with a similar fireproofing material at the points of entry into the junction box and actuator. The intumescent material protecting the

# 5

## Installation

gland connectors is formed to shape by the manufacturer to completely cover the connector. Install the protective fireproofing material in accordance with the manufacturer's installation instructions. Seal all gaps and joints around the fireproofing system with a suitable fireproofing caulking.

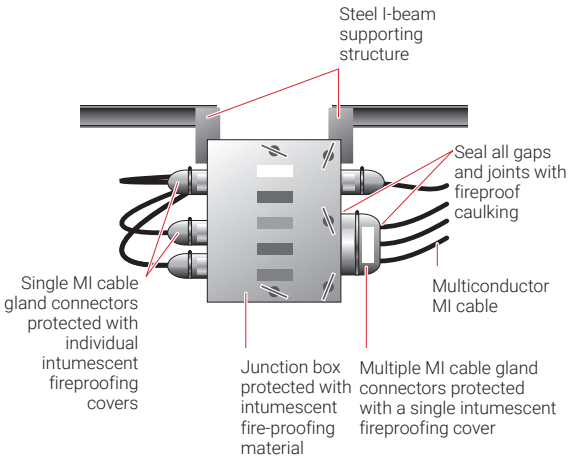

**Figure 20: Fireproofing gland connectors into junction box**

# 5

## Installation

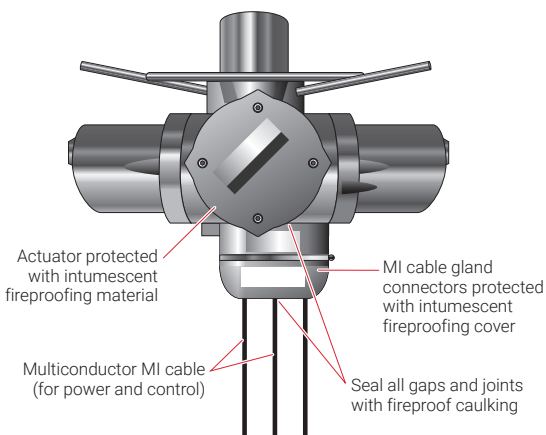

**Figure 21: Fireproofing gland connectors into actuator**

### 5.5 Cable Terminations

MI industrial wiring cables are typically supplied with factory installed terminations. These cables are ready to connect into junction boxes and other equipment as soon as they are received at the job site.

Where field installed terminations are required, nVent PYROTENAX Pyropak termination kits are available with either a mastic sealing compound or epoxy sealing compound. Both kits are approved for use in hazardous and nonhazardous areas. Refer to the Termination Kits data sheet H58421 for further details.

Prior to installing field terminations, check the cable with a 500 V megohmmeter to ensure the IR is acceptable (see Section 6). Follow the instructions supplied with the Pyropak kits to complete the cable termination.

# 5

## Installation

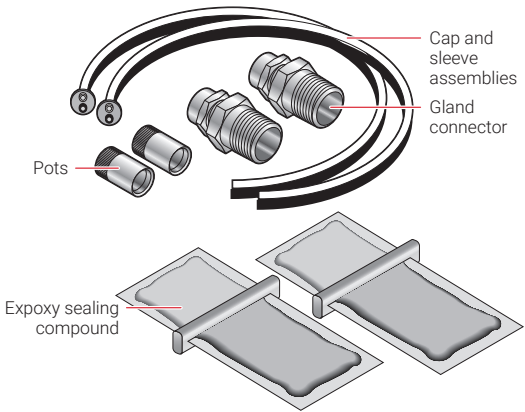

**Figure 22: Termination kit with epoxy sealing compound**

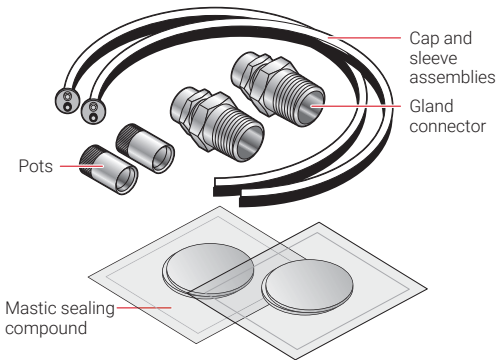

**Figure 23: Termination kit with mastic sealing compound**

# 6

## Testing and Commissioning

nVent recommends that the Cable Inspection Record in Appendix B be completed during testing and commissioning and kept for future reference

### 6.1

#### Tests

Visually inspect cables and terminations and check the insulation resistance (IR) prior to energizing.

##### Visual Inspection

- Visually inspect the cable sheath and connections to the cable for physical damage. Damaged cable must be repaired or replaced.
- Check that no moisture is present in junction boxes and other enclosures.
- Ensure that electrical connections are tight and grounded.
- Ensure that the cable carries the correct circuit identification and that there have been no unauthorized modifications to the cables.
- Verify that all junction boxes are appropriate for the area classification and correctly sealed, and that the cable glands are tight and correctly fitted into junction boxes

##### IR Test

IR testing is conducted using a megohmmeter and tests the integrity of the cable between the conductors and the cable sheath, and between conductor pairs in multiconductor cables. If the terminations or heat shrinkable end caps are damaged, missing, or removed, moisture will enter the mineral insulation, resulting in low IR readings.

Prior to testing factory terminated cables, wipe both ends of the cable sheath, pot, and tails with a clean, dry cloth to remove any moisture which may result in erroneous results (such as low IR readings).

When testing unterminated cables, it may be necessary to remove the heat shrinkable tubing and strip back the cable sheath from both ends to ensure that the conductors do not touch the

# 6

## Testing and Commissioning

cable sheath and are spaced apart from each other. Reseal the ends once testing is complete.

### TEST EQUIPMENT

500 Vdc megohmmeter (calibrated).

### TEST CRITERIA

The minimum insulation resistance for a clean, dry, properly installed cable should reflect the values shown below, regardless of the cable length.

- When cables are received (also when terminating bulk cable).
  - In a warm, dry environment, IR readings should be 200 MΩ or higher.
  - In an outdoor environment or indoors in wet or humid conditions, IR readings should all be above 100 MΩ.
  - Any large difference in readings between similar cables under similar conditions should be investigated.
- Prior to initial start-up (commissioning) – minimum 25 MΩ.
- After any maintenance or repair work – minimum 25 MΩ.



**Important: If IR readings are low, follow the instructions in Appendix A to dry out the cable.**

### Repairs

Use only MI cable and components when replacing any damaged cable. Repairs should be performed only by qualified personnel and to nVent requirements. Retest the system after repairs.



**WARNING: Damage to cables or components can cause sustained electrical arcing or fire. Do not energize cables that have been damaged. Damaged cable or terminations may need to be repaired or replaced. Damaged cable should be repaired by a qualified person.**

# 6

## Testing and Commissioning

---

### Test Procedure

The megohmmeter connection to check the IR of the MI cable between the conductors and the cable sheath, and between conductor pairs is shown in Figure 24.

### Insulation Resistance Test

1. Set megohmmeter test voltage at 0 Vdc.
2. Connect the positive (+) (earth) lead to the cable sheath.
3. Connect the negative (-) (line) lead to one conductor.
4. Turn on the megohmmeter and set the voltage to 500 Vdc; apply the voltage for one minute. Meter needle should stop moving. Rapid deflection indicates a short. Note the insulation resistance value. It should correspond to the values shown under Test Criteria.
5. Turn off the megohmmeter.
6. If testing a single conductor cable, proceed to Step 7. If testing a multiconductor cable, proceed to Step 8.
7. Testing is complete. If the megohmmeter does not self discharge, discharge phase connection to ground with a suitable grounding rod. Disconnect the megohmmeter.
8. If testing a multiconductor cable, repeat Steps 3 through 5 for remaining conductors.
9. Next, remove the positive (+) (earth) lead from the cable sheath and connect it to one of the other conductors.
10. Test the cable as in Steps 3 through 5.
11. Repeat for all conductor pair combinations.
12. Testing is complete. If the megohmmeter does not self discharge, discharge phase connection to ground with a suitable grounding rod. Disconnect the megohmmeter.

# 6

## Testing and Commissioning

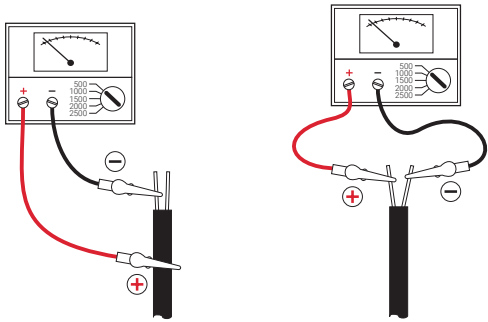

**Figure 24: IR test between cable sheath and conductor and between conductor pairs**



# 6

## Testing and Commissioning

---

# 7

## Troubleshooting Guide

---

---

### Symptom

---

Insulation resistance is less than expected

---

Short circuits and direct earth faults

# 7

## Troubleshooting Guide

Probable Causes	Corrective Action
1. Rain or high humidity.	(1) Dry tails and face of seal. Inspect power connection box for moisture or signs or tracking. Dry out connections and retest.
2. Nicks or cuts in the cable sheath, with moisture present.	(2, 3, 4, 5) Visually inspect or fault locate cable to find damaged section of cable. Repair or replace cable or contact nVent technical support for assistance.
3. Kinked or crushed cable.	
4. Arcing created by damage to the cable.	
5. Welding splatter.	
6. Presence of moisture in termination or temporary seal.	
7. Damaged termination or temporary seal.	(6) Remove termination or temporary seal. Dry out cable following the procedure in Appendix A. Replace termination or seal.
1. Physical damage to cable is causing a direct short from conductor to sheath.	(7) Replace termination or seal.
2. Misalignment of the conductors within the seal or incorrect and untidy completion of the sheath stripping procedure during termination.	(1) Check for visual indications of damage around any area where there may have been maintenance work. Repair or replace damaged cable and/or terminations.
3. Conductors shorted to sheath when cut at factory (only for unterminated cables)	(2) Remake termination.
	(3) Remove short and reseal end.

# 8

## Appendixes

### 8.1 Appendix A: Improving Insulation Resistance (IR)

To maintain the high performance of MI cable, the cable must be properly stored and the ends must remain sealed. Damaged terminations or heat shrinkable end caps that are damaged, missing, or removed will cause the magnesium oxide insulation (white powder) to absorb moisture, lowering the IR. The cable must be “heated out” to remove the moisture and bring the IR back to an acceptable level.

If the IR of a factory terminated cable tests below acceptable limits (see Section 6), the cable terminations must be removed before heating out the cable. Follow the troubleshooting guide in Section 7 before removing the terminations.



**Important: Moisture will not normally penetrate more than 12 in (300 mm) into the cable.**

If moisture is detected in the cable, use an oxy-acetylene or mapp gas torch with a large flame and “heat out” the cable beginning 12 in (300 mm) back from the end. Gradually stroke toward and past the cable end. Alloy 825 sheath cables should be heated to a dull red color. Take care not to overheat any one area of the cable sheath as this could damage the cable.

Use a short sweeping motion of the torch and heat about 2 in (50 mm) of cable at a time, repeating 4 to 5 times. Stroke the flame towards the cable end as shown in Figure 25. Do not stroke the flame in the opposite direction as this will drive the moisture into the cable. Gradually move the flame toward the end while maintaining the short sweeping motion of the torch (Figure 26). If you heat toward the cable end too quickly you may skip over the moisture and drive it further back into the cable.

Repeat the above procedure several times always beginning 12 in (300 mm) back from the cable end.

# 8

## Appendixes

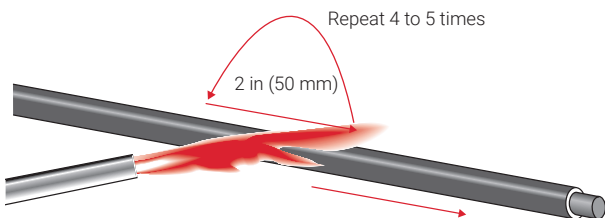

**Figure 25: Heat 2 in (50 mm) at a time**

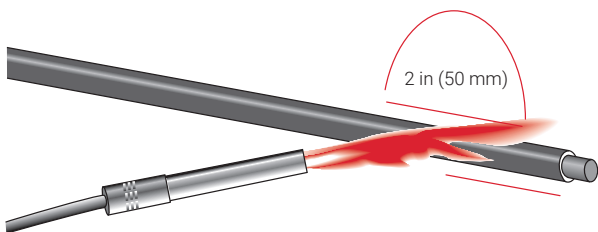

**Figure 26: Stroke flame towards end**

When first heated, the IR of the cables will decrease; however, after the flame has been removed and the cable cools, the IR will increase to an acceptable level if the moisture has been driven out. On completion, check IR with a 500 Vdc megohmmeter following the instructions in Section 6. If working with shielded twisted pair cable, also test IR between the sheath and inner shield. Reseal cable end with adhesive lined heat shrink tubing until ready to terminate cable.

# 8

## Appendixes

### 8.2 Appendix B: Cable Inspection Record

Megohmmeter manufacturer/model

Megohmmeter date of last calibration

INSULATION RESISTANCE TEST (Receipt of Cables)

Note: See Section 6 for minimum IR readings

Cable Reference No.	Tag No.	IR Conductor to Sheath	

Performed by \_\_\_\_\_ Company \_\_\_\_\_

Witnessed by \_\_\_\_\_ Company \_\_\_\_\_

#### nVent

7433 Harwin Drive

Houston, TX 77036

USA

Tel +1.800.545.6258

Fax +1.800.527.5703

thermal.info@nvent.com / **nVent.com**

# 8

## Appendixes

---

---

Voltage setting: 500 Vdc

Accuracy/full scale

---

	IR Conductor to Conductor	Date

Date

Date

---

**nVent**

250 West St.

Trenton, Ontario

Canada K8V 5S2

Tel +1.800.545.6258

Fax +1.800.527.5703

thermal.info@nvent.com / **nVent.com**

**North America**

Tel +1.800.545.6258  
Fax +1.800.527.5703  
thermal.info@nvent.com

**Europe, Middle East, Africa**

Tel +32.16.213.511  
Fax +32.16.213.604  
thermal.info@nvent.com

**Asia Pacific**

Tel +86.21.2412.1688  
Fax +86.21.5426.3167  
cn.thermal.info@nvent.com

**Latin America**

Tel +1.713.868.4800  
Fax +1.713.868.2333  
thermal.info@nvent.com



[nVent.com](http://nVent.com)

©2019 nVent. All nVent marks and logos are owned or licensed by nVent Services GmbH or its affiliates. All other trademarks are the property of their respective owners. nVent reserves the right to change specifications without notice.

Pyrotenax-IM-H57987MIndustrialwiring-EN-1901