

## FOR ENERGY EFFICIENT CONTROL OF HWAT-L/M/R HEATING CABLES



### PRODUCT OVERVIEW

The nVent RAYCHEM HWAT-T50 thermostat is designed for operation with the nVent RAYCHEM HWAT Hot Water Temperature Maintenance System.

It is compatible with:

HWAT-L  
HWAT-M  
HWAT-R

### PRODUCT FEATURES

Temperature control using a line sensor

Manual ON/OFF by 2-pole power switch

Easy-to-read display with blue backlight

Built-in timer function

5 operation modes

- Comfort
- Economical
- Manual
- Timer
- Off

Read-out of actual pipe sensor temperature

Monitor temperature of hot water pipe. In the event of a sensor failure, the heating system is switched off.

The HWAT system is controlled and monitored by a pipe (line) sensor.

## TECHNICAL DATA

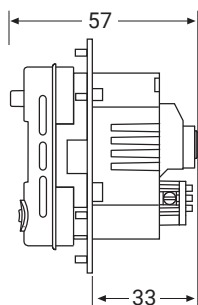
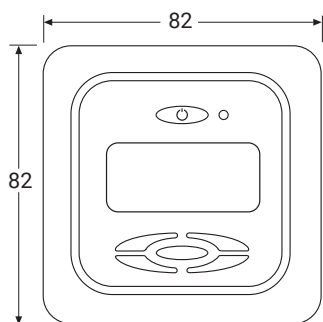

Supply voltage	180-253 VAC, 50/60 Hz
Relay output	Heating cable 230 VAC, max 16A
Temperature range line sensor	0°C to +70°C
Temperature setting range*	37-65°C <i>Default temperature 50°C</i>
Ambient temperature - operation	0°C to +40°C
Ambient temperature - transportation	-20°C to +55°C
Accuracy-line sensor	+/-1°C
Switching hysteresis	+/-2°C with line sensor
Clock function	3 pre-programmers: Eco, Comfort and Timer editable in blocks of 30 min; Daily programmable
Back-up for set values	Non-volatile memory
Back-up for time and date	7 days
Protection class	IP21
Terminals	Max. 2, 5 mm <sup>2</sup>
Line sensor	NTC, 10K / 25°C with 3 m cable
Sensor cable diameter	4 mm
Sensor tip diameter	7 mm, length 20 mm
Dimensions	H 82 x W 82 x D 57 mm
Frame	Color Polar white RAL 9010
Approvals	RCM approved
*Please consider local hygiene standard guidelines	

## SYSTEM INFORMATION

RAYCHEM HWAT-T50 thermostats may be used with HWAT-L/M/R circuits up to 50 metres.

## ORDERING INFORMATION

HWAT-T50-C (China)*	3000-4789
HWAT-T50-A (Australia)*	3000-4790
Mounting box for HWAT-T50-A	3000-4791
Adapter front plate for square box	1244-010134
*3 meter line sensor provided as a standard	

## COMPATIBILITY WITH WALL BOXES

HWAT-T50-C: will be compatible with 86 mm square box for in-wall installation together with the adapter (1244-010134). The 86 mm square mounting box not included.

## ACCESSORIES

N10K sensor, 3 m	1244-002952
------------------	-------------

**Direct, connection – e.g. single heating circuit**

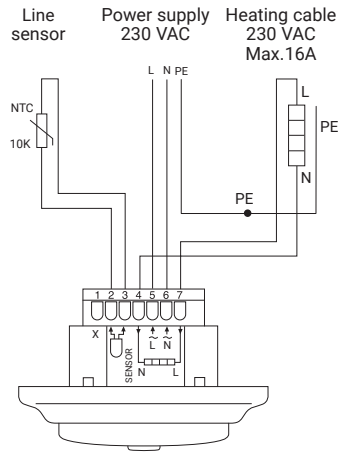

**Connection via contactor – e.g. 3 heating circuits**

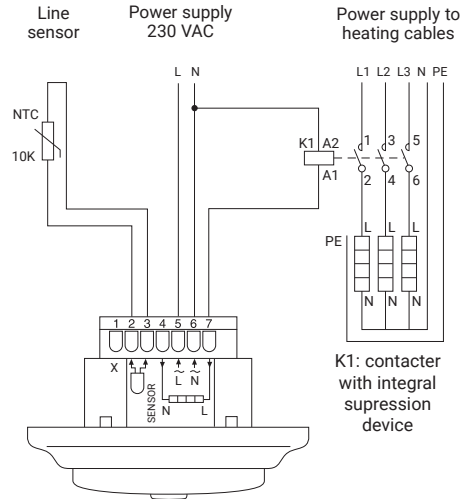

**!** Do not use contactor without suppression device.

**Asia Pacific**

Tel +86.21.2412.1688  
 Fax +86.21.5426.3167  
 cn.thermal.info@nvent.com

**Australia**

Tel +61 2 97920250  
 Fax +61 2 97745931



[nVent.com](http://nVent.com)

Our powerful portfolio of brands:

**CADDY ERICO HOFFMAN RAYCHEM SCHROFF TRACER**