

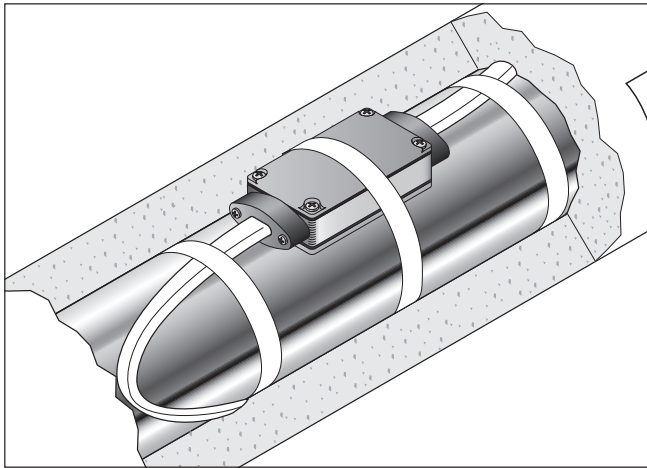

RAYCHEM

PMKG-LS

Low-Profile Splice Connection Kit Installation Instructions



DESCRIPTION

The nVent RAYCHEM PMKG-LS is a NEMA Type 4X rated splice kit designed for use with RAYCHEM BTV-CR, BTV-CT, QTVR-CT, LBTV2-CT, and KHP-CR parallel heating cables. It is designed to be placed on the pipe, under the insulation and cladding.

For additional information contact your nVent representative or call (800) 545-6258.

TOOLS REQUIRED

- Wire cutters
- Needlenose pliers
- Screwdriver
- Utility knife

ADDITIONAL MATERIALS REQUIRED

- Two grommets: ⁽¹⁾
PMK-GK-10 P/N 222724-000 (Package of ten grommets)
- Glass cloth tape
 - GT-66 Installation temperature above 40°F (4°C)
 - GS-54 Installation temperature above -40°F (-40°C)

⁽¹⁾ Required for LBTV2 (see "Identify heating cable type" on page 2)

APPROVALS

Hazardous Locations



BTV-CR, BTV-CT, QTVR-CT and LBTV2-CT heating cables only

- Class I, Div. 2, Groups A, B, C, D
- Class II, Div. 2, Groups F, G
- Class III



Nonhazardous Locations



KHP-CR heating cables only

KIT CONTENTS

Item	Qty	Description
A	1	Body
B	2	Pressure plates with captive screws
C	2	Red grommets (not for use with LBTV2)
D	2	Gaskets
E	2	Covers with captive screws
F	1	Label

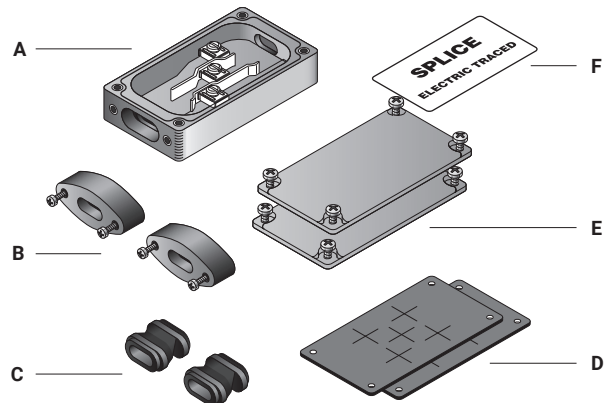

⚠ WARNING:

This component is an electrical device that must be installed correctly to ensure proper operation and to prevent shock or fire. Read these important warnings and carefully follow all of the installation instructions.

- To minimize the danger of fire from sustained electrical arcing if the heating cable is damaged or improperly installed, and to comply with the requirements of nVent, agency certifications, and National Electrical Codes, ground-fault equipment protection must be used. Arcing may not be stopped by conventional circuit breakers.

- Component approvals and performance are based on the use of nVent-specified parts only. Do not use substitute parts or vinyl electrical tape.
- The black heating cable core is conductive and can short. It must be properly insulated and kept dry.
- Damaged bus wires can overheat or short. Do not break bus wire strands when scoring the jacket or core.
- Keep components and heating cable ends dry before and during installation.

- Bus wires will short if they contact each other. Keep bus wires separated.
- Use only fire-resistant insulation materials, such as fiberglass wrap or flame-retardant foam.

IDENTIFY HEATING CABLE TYPE

- Select correct grommet from table below.

Heating Cable	Type	Grommet
BTV, QTVR	-CR or -CT	RED
LBTV2	-CT	K (Order separately)
KHP	-CR	RED

⚠ WARNING: Use of the wrong grommet can result in leaks, cracked components, shock or dielectric failure, and will invalidate approvals and certifications.

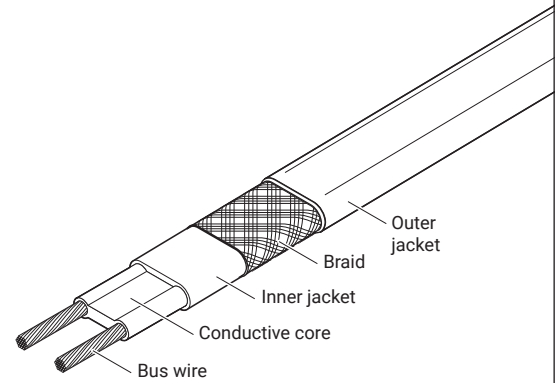

BTV-CR, BTV-CT, QTVR-CT, LBTV2-CT, KHP-CR

1

- Allow extra heating cable as shown.

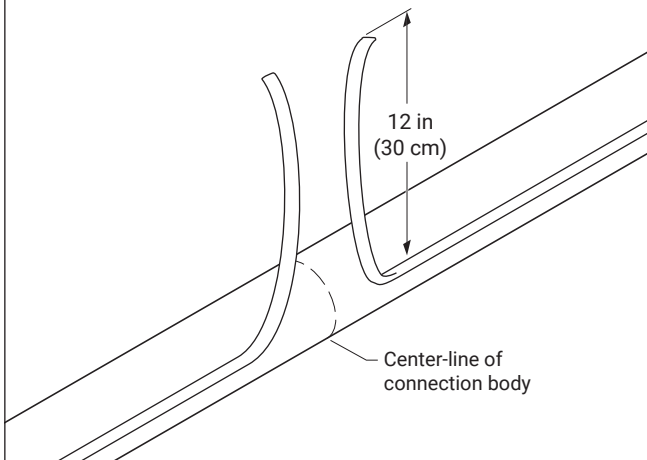

2

- Slide parts onto heating cable in order shown.

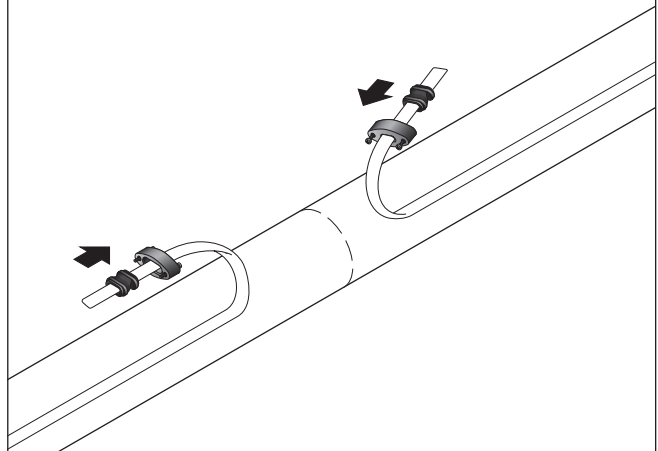

3

Do not cut braid.

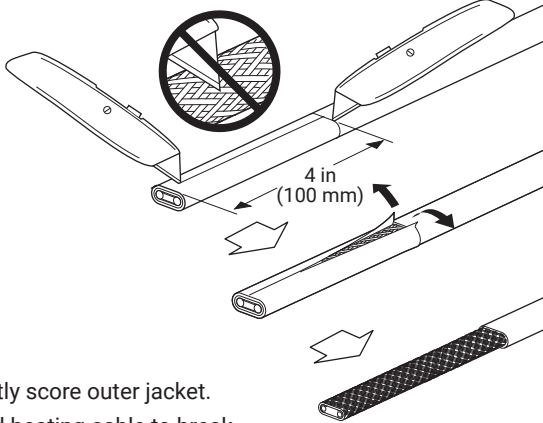

- Lightly score outer jacket.
- Bend heating cable to break jacket at score, then peel off jacket.

4

- Push braid back to create a pucker.

- At pucker use a screwdriver to open braid.

- Bend heating cable and work it through opening in braid.

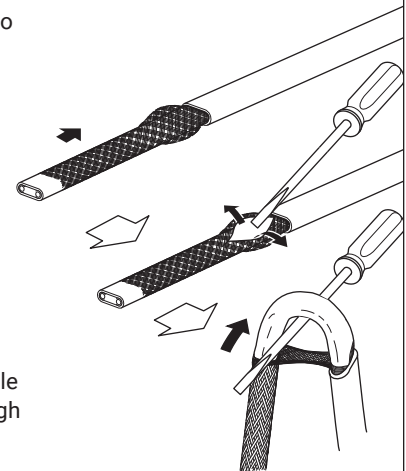

5

- Pull braid tightly to center of cable to make a pigtail.

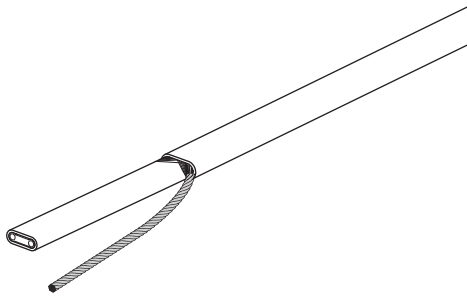

6

Do not cut bus wires

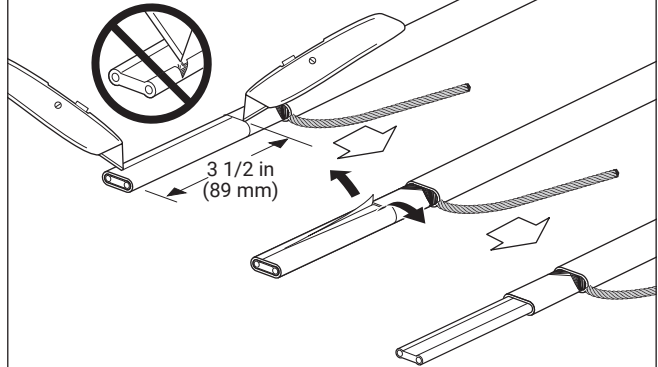

- Lightly score inner jacket.
- Peel off jacket.

7

- Notch core.

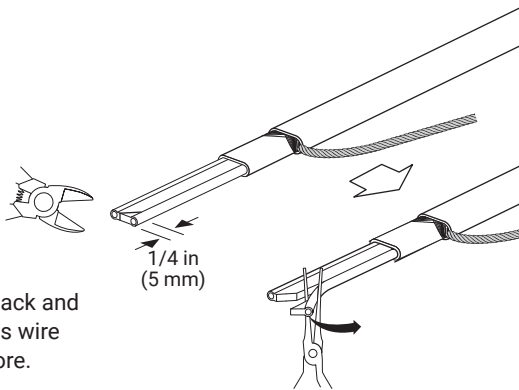

- Twist back and peel bus wire from core.

8

- Score core between bus wires and inner jacket.

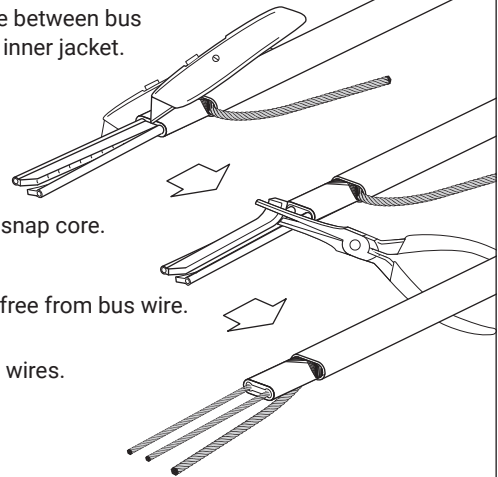

- Bend and snap core.
- Peel core free from bus wire.
- Clean bus wires.

9

- Push heating cable into the body.
- Slide grommets into cavities and seat.
- Tighten pressure plate screws to body.

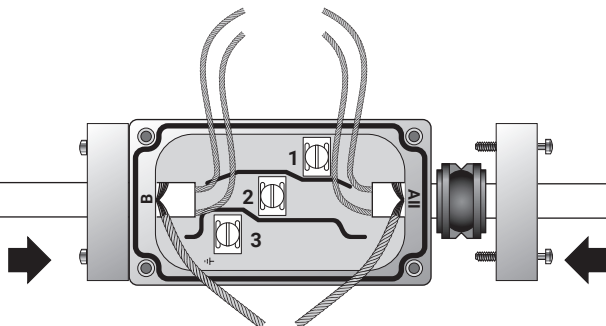

10

- Remove screws, lockwashers and clamps.
- Push braid wires away from bus wires.
- Position wires on blocks.
- Refit clamps, lockwashers, screws, and tighten.
- Trim all extra lengths of wire and remove any loose wires.

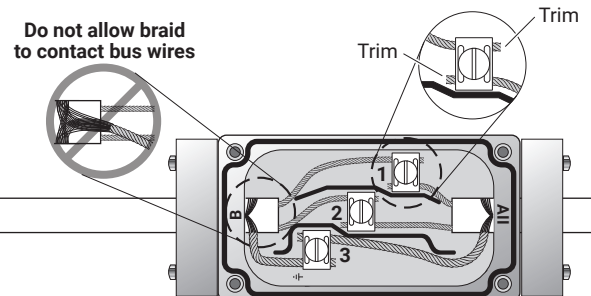

11

- Remove release liner, if present, from gasket.
- Position gaskets and covers on body.
- Tighten covers to body.

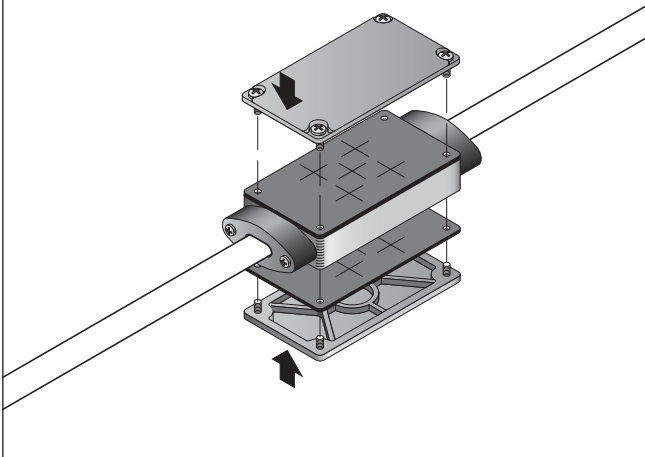

12

- Tape splice connection to pipe.
- Loop and tape extra heating cable to pipe.
- Apply insulation and cladding.
- Install label on outside of cladding.
- Leave these instructions with the end user for future reference.

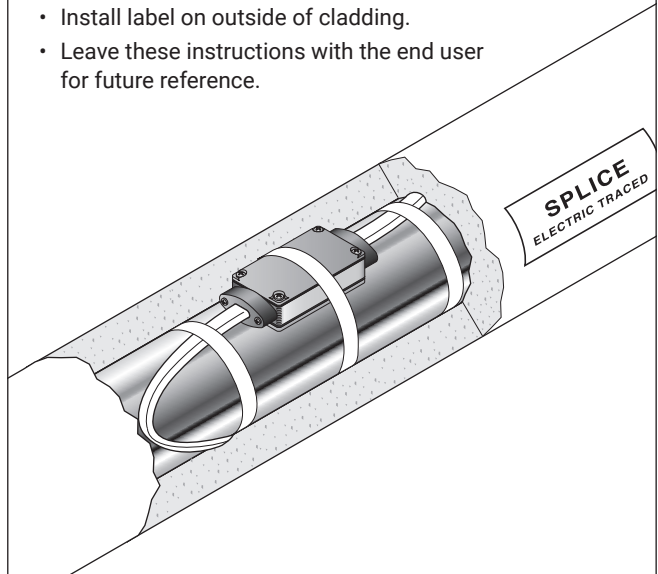

North America

Tel +1.800.545.6258
Fax +1.800.527.5703
thermal.info@nvent.com

Europe, Middle East, Africa

Tel +32.16.213.511
Fax +32.16.213.604
thermal.info@nvent.com

Asia Pacific

Tel +86.21.2412.1688
Fax +86.21.5426.3167
cn.thermal.info@nvent.com

Latin America

Tel +1.713.868.4800
Fax +1.713.868.2333
thermal.info@nvent.com



nVent.com