

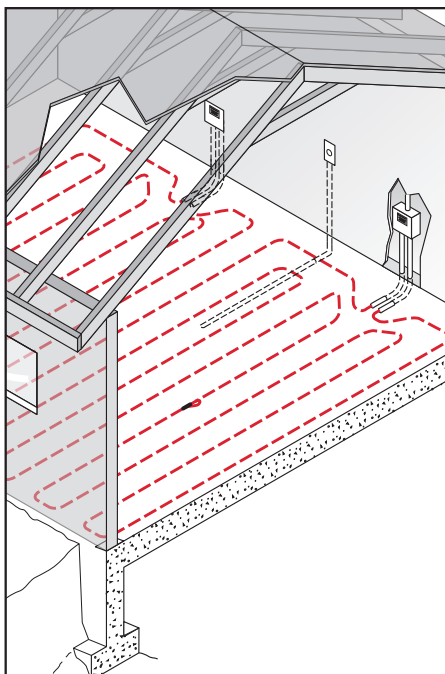

RAYCHEM

RaySol System

Installation and Operation Manual for Heat Loss Replacement and Freezer Frost Heave Prevention Systems



Important Safeguards and Warnings

WARNING: FIRE AND SHOCK HAZARD

nVent RAYCHEM heat-tracing systems must be installed correctly to ensure proper operation and to prevent shock and fire. Read these important warnings and carefully follow all the installation instructions.

- To minimize the risk of fire from sustained electrical arcing if the heating cable is damaged or improperly installed and to comply with nVent requirements, agency certifications, and national electrical codes, ground-fault equipment protection must be used on each heating cable branch circuit. Arcing may not be stopped by conventional circuit breakers.
- Approvals and performance are based on the use of nVent RAYCHEM parts only. Do not substitute parts or use vinyl electrical tape.
- Bus wires will short if they contact each other. Keep bus wires separated.
- Connection kits and heating cable ends must be kept dry before and during installation.
- The black heating cable core is conductive and can short. They must be properly insulated and kept dry.
- Damaged bus wires can overheat or short. Do not break bus wire strands when scoring the jacket or core.
- Damaged heating cable can cause electrical arcing or fire. Use only plastic cable ties to secure the heating cable to the reinforcement. Do not use metal attachments such as tie wire.
- Do not attempt to repair or energize damaged heating cable. Remove damaged sections at once and replace them with a new length using the appropriate nVent RAYCHEM splice kit. Replace damaged connection kits.
- Use only fire-resistant insulation materials such as fiberglass wrap or flame-retardant foams.

Table of Contents

1	General Information	1
	1.1 Use of the Manual	1
	1.2 RaySol Applications	2
	1.3 Installation Methods	2
	1.4 Safety Guidelines	2
	1.5 Approvals	3
	1.6 Warranty	3

2	General Installation Guidelines	4
	2.1 Heating Cable Storage	4
	2.2 Pre-Installation Checks	4

3	Attaching RaySol to the Bottom of Concrete Floors	
	3.1 Heating Cable Installation	5
	3.2 General Installation Guidelines	6
	3.3 Insulating the System	8
	3.4 Insulation Installation	8

4	Embedding RaySol in Mortar or Concrete	9
	4.1 Heating Cable Installation	9
	4.2 Heating Cable Connections	11

5	Placing RaySol in Conduit Buried in the Subfloor	14
	5.1 Heating Cable Installation	14
	5.2 Heating Cable Connections	18

6	Power Supply and Electrical Protection	20
	6.1 Voltage Rating	20
	6.2 Circuit Breaker Rating	20
	6.3 Electrical Loading	20
	6.4 Ground-Fault Protection	20
	6.5 Important Power Supply Safeguards	21

7	Control, Monitoring and Power Distribution	22
	7.1 Control Systems	22
	7.2 Power Distribution	24

8	Commissioning and Preventive Maintenance	28
	8.1 Tests	28

9	Test Procedures	29
	9.1 System Tests	29
	9.2 Fault Location Tests	33

10	Troubleshooting Guide	36
-----------	------------------------------	-----------

11	Appendix	38
-----------	-----------------	-----------

12	Installation and Inspection Records	40
-----------	--------------------------------------------	-----------

1

General Information

1.1 Use of the Manual

This manual covers the installation of nVent RAYCHEM RaySol self-regulating heating cables and connections for floor heating and freezer frost heave prevention. The manual covers general heating cable installation procedures and specific installation details and shows available connection kits for the different applications. The manual also discusses controls, testing, and periodic maintenance.

This manual assumes that the proper floor heating or freezer frost heave prevention designs have been completed according to the Heat Loss Replacement Design Guide (H58157) and the Freezer Frost Heave Prevention Design Guide (H58139). Only the applications described in Section 1.2 are approved by nVent for RaySol systems when used with approved RAYCHEM connection kits. The instructions in this manual and the installation instructions included with the connection kits, control systems, power distribution systems, and accessories must be followed for the nVent warranty to apply and to conform to agency approvals requirements. Contact your nVent representative for other applications and products.

For additional information, contact:

nVent

7433 Harwin Drive
Houston, TX 77036
USA

Tel: +1.800.545.6258

Tel: +1.650.216.1526

Fax: +1.800.527.5703

Fax: +1.650.474.7711

thermal.info@nVent.com

www.nVent.com



Important: For the nVent warranty and agency approvals to apply, the instructions that are included in this manual and with associated products must be followed.

1

General Information

1.2 RaySol Applications

RaySol heating cable systems are approved and qualified for the applications listed below:

- Heat loss replacement
- Comfort floor heating
- Radiant space heating
- Freezer frost heave prevention

For heating cable applications other than those listed above, please see your nVent representative or call us at (800) 545-6258.

1.3 Installation Methods

The RaySol system may be installed in 3 different ways:

- Attached to the bottom of the concrete floor
- Embedded in mortar or concrete
- Placed in conduit buried in concrete or the subfloor

TABLE 1: INSTALLATION SUMMARY

Applications	Installation Method
Heat loss replacement	Attached to bottom of the concrete floor
Comfort floor heating	Embedded in mortar or concrete
Radiant space heating	Embedded in mortar or concrete
Freezer frost heave prevention	Placed in conduit buried in concrete of the subfloor

1.4 Safety Guidelines



The safety and reliability of any heat-tracing system depends on the quality of the products selected and the manner in which they are installed and maintained. Incorrect design, handling, installation, or maintenance of any of the system components could damage the system and may result in electric shock, or fire. To minimize these risks and to ensure that the system performs reliably, read and carefully

1

General Information

follow the information, warnings, and instructions in this guide.

Pay special attention to the following:

- Important instructions are marked  **Important**
- Warnings are marked  **WARNING**

1.5 Approvals

RaySol systems carry agency approvals for the different applications shown in Section 1.2. For detailed information on which approvals are carried for the specific application, refer to the Heat Loss Replacement Design Guide (H58157) and the Freezer Frost Heave Prevention Design Guide (H58139).

1.6 Warranty



nVent standard limited warranty applies to all products. An extension of the limited warranty period to ten (10) years from the date of installation is available if a properly completed online warranty form is submitted within thirty (30) days from the date of installation. You can access the complete warranty on our web site at nVent.com

2

General Installation Guidelines

2.1 Heating Cable Storage

- Store the heating cable in a clean, dry location. Temperature range: 0°F (-18°C) to 140°F (60°C).
- Protect the heating cable from mechanical damage.

2.2 Pre-Installation Checks

Check Materials Received

TABLE 2: RAYSOL HEATING CABLE

Supply voltage	Catalog number
110 – 120 V	RaySol 1
208 – 277 V	RaySol 2

- Review the heating cable design and compare the list of materials to the catalog numbers of the heating cables and connection kits received to confirm that the proper materials are on site. The heating cable type is printed on its jacket.
- Ensure that the service voltage available is correct for the RaySol heating cable selection.
- Inspect the heating cable and connection kits to ensure there is no in-transit damage.
- Verify that the heating cable jackets are not damaged by conducting the insulation resistance test (refer to Section 10) on each reel of heating cable. Do not power the heating cable when it's on the reel.



Important: Site conditions and the design of floors vary widely. It is the responsibility of the installing contractor to follow all of the instructions and warnings in this manual and to use generally accepted, sound construction practices to ensure a proper installation.

3

Attaching RaySol to the Bottom of Concrete Floors

3.1 Heating Cable Installation

Positioning the Heating Cable

When positioning the cable follow these instructions:

- Arrange the heating cable in a serpentine pattern to uniformly cover the heated area.
- Do not extend the heating cable beyond the room or heated area in which it originates.
- Maintain the design heating cable spacing within 1 in (2.5 cm).
- Do not route the heating cable closer than 4 in (10.2 cm) to the end of the concrete floor, drains, anchors, or other material in the concrete.
- Do not cross expansion, crack-control, or other joints.



Important: Retain the heating cable layout for future reference.

Attaching the Heating Cable to the Bottom of the Concrete Floor

The heating cable may be installed using the insulation to hold the cable in contact with the floor (Figure 1) or in a channel attached to the floor (Figure 2).

If the floor insulation will press the heating cable firmly against the floor, the heating cable may be loosely fastened in place using eyelet-type cable ties. Attach the cable tie to the floor approximately every 2 ft (0.6 m). Tighten the cable tie by hand to hold the heating cable. Between tie points the heating cable will droop slightly. The droop will be taken out after the insulation is installed.

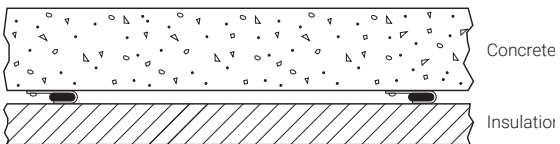

Figure 1: Heating cable held by rigid floor insulation

3

Attaching RaySol to the Bottom of Concrete Floors

When there is equipment space below the floor, insulation is supported by a drop ceiling below the equipment. The heating cable must be fastened to the bottom of the floor in such a way that it is in contact with the floor at all points. In this case, the insulation cannot be used to press the heating cable against the floor.

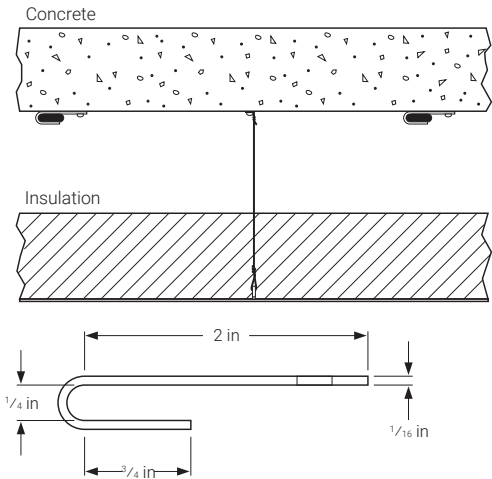

Figure 2: Heating cable held by metal channel

Figure 2 shows a metal channel that should be fabricated or purchased to hold the heating cable against the floor. For best results fabricate the channel from 20- to 24- gauge sheet stock in 48-inch lengths. Attach the channel to the bottom of the floor. After all of the channel is installed, tuck the heating cable into the J-shaped lip in the channel. Gently squeeze the channel shut every 2 ft (0.6 m) to hold the heating cable in place.

3.2 General Installation Guidelines

Installing Junction Boxes

Terminate the heating cable in a UL Listed or CSA Certified junction box suitable for the location. Where possible, arrange the heating cable layout so that the heating cable end seal is placed near

3

Attaching RaySol to the Bottom of Concrete Floors

the junction box where it is easily located and accessible if maintenance is ever needed.

Installing Power Connection and End Seal

Install the nVent RAYCHEM FTC-P power connection and end seal kit only after the following steps have been completed:

- The entire length of heating cable making up the circuit is installed.
- All splices have been installed (if any).
- The floor insulation has been installed.
- The heating cable has an insulation resistance greater than 1000 megohms when tested at 2500 Vdc.

Follow the FTC-P installation instructions when installing the power connection and end seal.

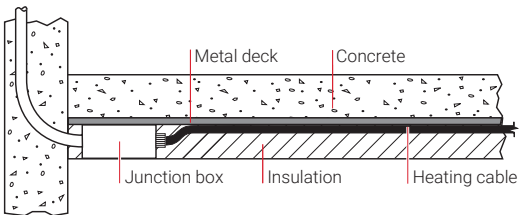

Figure 3: Typical installation for heating cable attached to the bottom of concrete floors

Splicing the Cable

If the insulation resistance of the heating cable is greater than 1000 megohms, complete the splice according to the instructions packaged with the FTC-HST splice kit. After completing the splice, repeat the insulation resistance test on the completed heating cable circuit. Mark the location of the splice on the heating cable layout drawings for future reference.

3

Attaching RaySol to the Bottom of Concrete Floors

Installing Circuit Tags and Warning Labels

- Attach the RaySol circuit tag to the cable inside the power connection junction box. Write the operating voltage and heating cable length in the blanks provided.
- Attach a tag to each branch circuit breaker with the identification and location of the floor heating circuit and affix Ground-Fault Protection Device (GFPD) labels as required by the GFPD manufacturer.
- Place a warning label on the cover of the power connection junction box.

3.3 Insulating the System

The heated area must be insulated with the correct thermal insulation (type and thickness) to maintain the desired floor temperature. Confirm that the insulation thickness agrees with the system design.

3.4 Insulation Installation

- Before installing the floor insulation, verify that the insulation is the proper type and thickness to provide the design R-value. Insufficient insulation will increase heat loss from the floor and may lead to lower floor temperatures.
- RaySol heating cables may be used in direct contact with fiberglass, most extruded polystyrene, and polyurethane insulation without exceeding the temperature rating of the insulation.
- If the insulation is being used to hold the heating cable to the floor, as in the case when the heating cable is attached to the bottom of the floor, ensure that the insulation is supported so that all points along the heating cable circuit are firmly in contact with the bottom of the floor.

4

Embedding RaySol in Mortar or Concrete

4.1 Heating Cable Installation

Precautions

- To ensure a long lasting, dependable system, the heating cable must be embedded in a structurally sound setting bed. A setting bed that crumbles, settles, or cracks can damage the heating cable. Always design the setting bed to applicable local codes, reinforce with wire mesh or rebar, and use high quality materials.
- When floor heating systems are installed in mortar or concrete, it is important to properly reinforce the setting bed.
- Heating cables must be anchored securely to maintain the correct spacing and depth. Attach heating cables with plastic cable ties. Do not use wire tie downs.
- The standard installation procedure is to attach the heating cable to the wire mesh or rebar that is attached to the subfloor. Do not staple the heating cable directly to a wooden subfloor.
- When installing RaySol in areas where a 5-mA Class A Ground-Fault Circuit Interrupter (GFCI) is required, such as a bathroom or kitchen, the circuit breaker size cannot exceed 30 A.



Important: Allow for setting bed expansion. If the floor tiles are constrained, they will crack or pop loose when the heating cable is energized. Therefore, be sure to allow a ½ in gap between the tile's edge and all room walls.

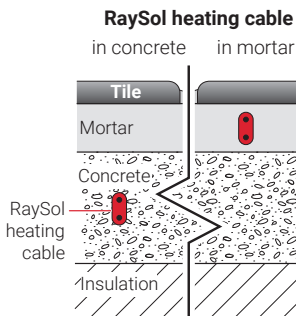



Figure 4: Typical comfort floor heating system installation

4

Embedding RaySol in Mortar or Concrete

 **Important: When installing RaySol in mortar or concrete, the heating cable must be continuously meggered during the concrete pour. The commissioning records shall contain the name and location of the installation, data of commissioning, commissioning person signature and must be retained by the end customer and nVent.**

Positioning the Heating cable

When positioning the cable follow these instructions:

- Arrange the heating cable in a serpentine pattern to uniformly cover the area to be heated.
- Do not extend the heating cable beyond the room or area in which it originates.
- Maintain the design heating cable spacing within 1 in (2.5 cm).
- Provide a setting bed at least $\frac{3}{4}$ in (1.9 cm) thick. The heating cable will stand on edge when it is bent. A deep setting bed will allow adequate cover and will also perform better thermally.
- Using plastic cable ties, attach the heating cable to reinforcing mesh approximately every 24 in (61 cm).
- Tension the cable ties by hand.
- Do not route the heating cable closer than 4 in (10 cm) to the edge of the setting bed, drains, anchors, pipes, or other material in the setting bed.
- Arrange the heating cable so that both the power connection and the end seal terminate in a UL Listed or CSA Certified junction box.
- Do not cross expansion, crack-control, or other joints.

 **Important: Retain the heating cable layout for future reference.**

Pouring the Mortar or Concrete

The following special precautions should be taken during the placement of the setting bed to protect the heating cable:

4

Embedding RaySol in Mortar or Concrete

- Do not hit the heating cable with tools, walk on the heating cable, or do anything else that may damage the heating cable jacket.
- Avoid an excessive drop height. Pour from no higher than 4 ft (1.2 m).
- Work mortar or concrete carefully during the placement to avoid dislodging or damaging the heating cable.
- Continuously monitor each heating cable circuit with a 2500 Vdc megohmmeter during the mortar setting bed placement. Watch for changes in the megohmmeter reading.

A decreasing megohmmeter reading may indicate damage to the heating cable. Make sure the ends of the heating cable are dry and megger the circuit again. If the megohmmeter reading is still low, stop the placement immediately and find the damage. Start inspecting at the area being worked and look for signs of outer jacket damage, such as cuts, punctures, or abrasion. Replace the damaged heating cable.

Allow the mortar or concrete to cure fully before energizing the heating cable.

4.2 Heating Cable Connections

Installing Junction Boxes

- Use UL Listed or CSA Certified electrical conduit that meets local electrical codes. The self-regulating RaySol heating cable automatically adjusts its output to prevent overheating, even when installed in plastic conduit.
- Protect both ends of the heating cable from where it leaves the mortar or concrete to the power connection junction box by installing the heating cable in electrical conduit. Extend the protective conduit at least 6 in (15 cm) into mortar. Each end of the heating cable may be pulled through minimum $\frac{3}{4}$ in (1.9 cm) conduit. Protect the heating cable by installing bushings on both ends of the conduit.

4

Embedding RaySol in Mortar or Concrete

- Bring both ends of the conduit into UL Listed or CSA Certified junction boxes suitable for the location.
- Do not connect the heating cable to the branch circuit conductors or install the end seal until after the mortar or concrete has been poured or the setting bed has been placed and all floor work is complete.
- Do not embed the end seal in mortar or concrete.

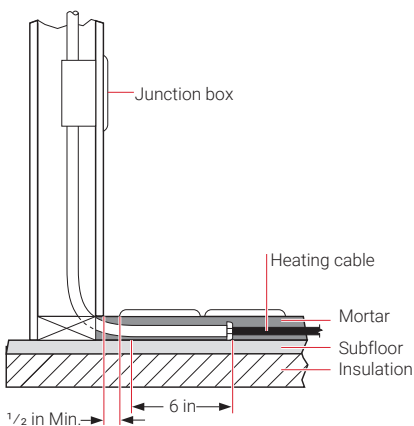

Figure 5: Protective conduit detail for heating cable in mortar or concrete

Installing the Power Connection and End Seal

Install the FTC-XC power connection and end seal after all floor work is complete. Follow the FTC-XC installation instructions when installing the power connection and end seal.

4

Embedding RaySol in Mortar or Concrete

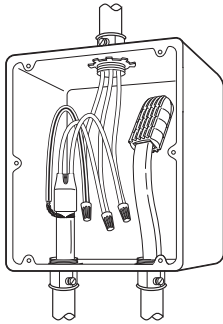

Figure 6: Junction box detail showing power connection and end seal

Installing Circuit Tags and Warning Labels

- Attach the RaySol circuit tag to the cable inside the power connection junction box. Write the operating voltage and heating cable length in the blanks provided.
- Attach a tag to each branch circuit breaker with the identification and location of the floor heating circuit and affix GFPD labels as required by the GFPD manufacturer.
- Place a warning label on the cover of the power connection junction box.

5

Placing RaySol in Conduit Buried in the Subfloor

5.1 Heating Cable Installation

Precautions

Note that heating cable splices cannot be pulled through conduit. Use only continuous lengths of heating cable. If splices are required, arrange intermediate pull boxes where splices can be made and be accessible.

Positioning and Installing the Conduit

When positioning the conduit follow these instructions:

- Arrange the conduit to uniformly cover the area to be heated.
- Do not extend the heating cable beyond the room or area in which it originates.
- Maintain the design conduit spacing within 1 in (2.5 cm).
- Use only UL Listed or CSA Certified $\frac{3}{4}$ in (1.9 cm) or 1 in (2.5 cm) rigid galvanized steel, rigid aluminum, or rigid PVC electrical conduit. Consult your local electrical code for any other specific requirements.
- Do not route the conduit closer than 4 in (10 cm) to the edge of the pavement, drains, anchors, or other material in the concrete.
- Arrange the conduit so that both the power connection and the end seal terminate in junction boxes.
- Position the conduit so that there is only one run of heating cable per conduit.
- Do not cross expansion, crack-control, or other joints.



Important: Retain the heating cable layout for future reference.

5

Placing RaySol in Conduit Buried in the Subfloor

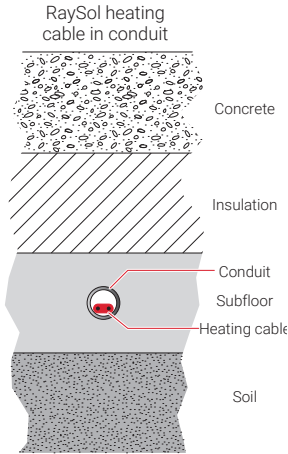

Figure 7: Typical freezer frost heave installation

Laying Down the Conduit

Install the conduit as indicated in the design drawings, observing good trade practices and national electric codes for electrical conduit.

Make all conduit bends with as large a radius as practical. Where the design calls for closer spacing than can be accomplished with the minimum bend radius, interleave adjacent runs of conduit or provide pulling fittings at the end of straight conduit runs. Seal all conduit ends and joints to prevent concrete entry during placement of the floor.

The design should comply with the following guidelines:

- The maximum length of RaySol heating cable that can be pulled through conduit is 500 ft (152.4 m).
- The maximum total degrees of conduit turns per run is 360 degrees.

5

Placing RaySol in Conduit Buried in the Subfloor

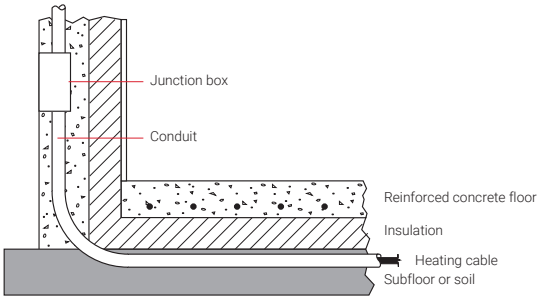

Figure 8: Typical conduit installation

Preparing the Cable for Pulling

The heating cable may be pulled through the conduit any time after the conduit and junction box are installed. However, it is best to wait until the concrete floor has been poured to minimize the chance of damage to the heating cable. Note that heating cable splices cannot be pulled through the conduit. Use only continuous lengths of heating cable or arrange intermediate pull boxes where splices can be made.

To prepare the heating cable for pulling (see Figure 9):

- Strip the outer black jacket back approximately 12 in (30 cm) to expose the braid.
- Push back and twist the braid to expose the blue inner jacket.
- Cut approximately 11½ in (29 cm) off the heating cable (blue jacket and black core) without cutting the braid.
- Trim the end of the heating cable, forming a point, by cutting along a 45 degree diagonal on both sides of the inner jacket and core. That will eliminate the sharp shoulder where the braid crosses the end of the heating cable.
- Make a loop with the braid.

5

Placing RaySol in Conduit Buried in the Subfloor

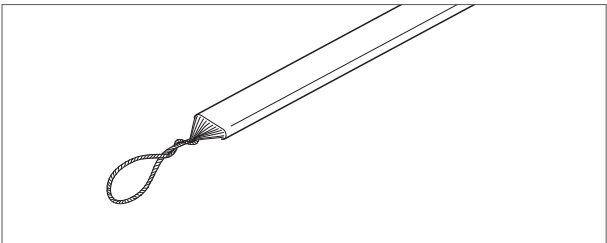
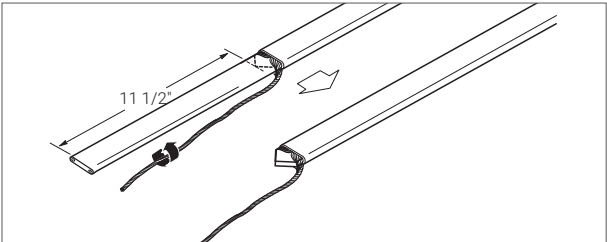
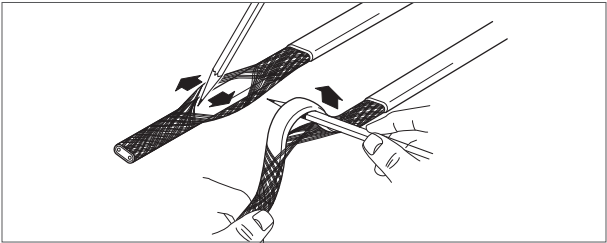
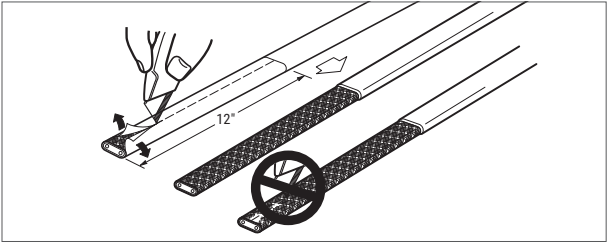

Figure 9: Preparing the heating cable for pulling through conduit

5

Placing RaySol in Conduit Buried in the Subfloor

Pulling the Cable

- Fasten the braid to a pulling eye or directly to the pulling cable.
- To prevent damage to the heating cable do not exceed a static pulling tension of 125 pounds (57 kg).
- If the maximum recommended pulling tension is exceeded, the braid will break just above the shoulder without damaging the heat-generating parts of the cable.
- Pull the heating cable through the conduit by its braid. Do not pull on the heating cable bus wires or on the white inner jacket and core. This would result in low heating cable power output.
- Do not use pulling compound when pulling RaySol heating cable through conduit. The use of pulling compound is not necessary and may reduce the power output of the cable.

5.2 Heating Cable Connections

Installing Junction Boxes

Terminate both ends of the conduit in UL Listed or CSA Certified junction boxes suitable for the location. Do not dead-end the conduit in the floor or else the end seal will be inaccessible.

Installing the Power Connection and End Seal

Install the FTC-XC power connection and end seal only after the following steps have been completed.

- All of the conduit has been installed.
- The junction box or boxes for the power connection and end seal have been installed.
- The heating cable has been pulled into the conduit.
- The heating cable has been tested for insulation resistance.

Follow the FTC-XC installation instructions when installing the power connection and end seal. See Figure 6.

5

Placing RaySol in Conduit Buried in the Subfloor

Installing Circuit Tags and Warning Labels

- Attach the RaySol circuit tag to the cable inside the power connection junction box. Write the operating voltage and heating cable length in the blanks provided.
- Attach a tag to each branch circuit breaker with the identification and location of the floor heating circuit and affix GFPD labels as required by the GFPD manufacturer.
- Place a warning label on the cover of the power connection junction box.

6

Power Supply and Electrical Protection

6.1 Voltage Rating

Verify that the supply voltage is either 120 or 208-277 V as specified by the RaySol system design and printed on the jacket of the heating cable.

6.2 Circuit Breaker Rating

Circuit breakers must be sized using the heating cable lengths shown in Section 12 Appendix Table A1. Do not exceed the maximum circuit length shown for each breaker size. Use circuit breakers that incorporate 30-mA ground-fault circuit protection, or provide equivalent levels of ground-fault protection.



Important: For areas where a Class A 5-mA ground-fault circuit interrupter (GFCI) is required (i.e. bathrooms), the circuit breaker size cannot exceed 30 A.

6.3 Electrical Loading

The maximum current draw for RaySol heating cable is shown in Section 12 Appendix Table A2. To size the transformer, multiply the total heating cable length (ft/m) by the appropriate current draw.

6.4 Ground-Fault Protection

If the heating cable is improperly installed or physically damaged to the point that water contacts the bus wires, sustained arcing or fire could result. If arcing does occur, the fault current may be too low to trip conventional circuit breakers. nVent, agency certifications and national electrical codes require both ground-fault protection of equipment and a grounded metallic covering on all heating cables. Ground-fault protection must be provided by the installer.



WARNING: To minimize the danger of fire from sustained electrical arcing if the heating cable is damaged or improperly installed, and to comply with nVent requirements, agency certifications, and national electrical codes, ground-fault equipment protection must be used on each heating cable branch circuit. Arcing may not be stopped by conventional circuit breakers.

6

Power Supply and Electrical Protection

⚠ WARNING: Shock Hazard. Disconnect all power before making connections to the heating cable.

6.5

Important Power Supply Safeguards

- Make sure that the heating cable load you are connecting is within the rating of the control system selected. Check the design drawings for the heating cable load.
- The electrical conduit that feeds wiring to the control device must have a low-point drain so condensation will not enter the thermostat enclosure
- Make sure that the line voltage you are connecting to the control system is correct. For proper wiring, follow the installation instructions enclosed with the control device.

7



Control, Monitoring and Power Distribution

7.1 Control Systems

There are various types of controls that may be used with RaySol.

Floor temperature sensing control must be used for heat loss replacement, comfort floor heating and freezer frost heave prevention applications. An ambient temperature control with an overlimit sensor must be used for radiant space heating applications. Where temperature control and temperature monitoring is desired, a nVent RAYCHEM ACS-30 or C910-485 controller is recommended.

TABLE 3: CONTROL SYSTEMS

Description	
Electronic thermostats and accessories	
	The nVent RAYCHEM ECW-GF is an ambient or slab-sensing electronic controller with 30-mA ground-fault protection. The controller can be programmed to maintain temperatures up to 200°F (93°C) at voltages from 100 to 277 V and can switch current up to 30 Amperes. The ECW-GF is complete with a 25-ft (7.6-m) temperature sensor and is housed in a NEMA 4X rated enclosure. The controller features an AC/DC dry alarm contact relay.
ECW-GF	
	An optional ground-fault display panel (ECW-GF-DP) can be added to provide ground-fault or alarm indication in applications where the controller is mounted in inaccessible locations.
ECW-GF-DP	

7

Control, Monitoring and Power Distribution

TABLE 3: CONTROL SYSTEMS

Description

Electronic controllers and sensors

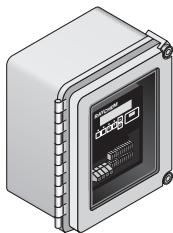

C910-485

The nVent RAYCHEM C910-485 is a compact, full featured, microprocessor-based, single-point commercial heating cable controller. The C910-485 provides control and monitoring of electrical heating cable circuits for commercial heating applications, with built-in 30 mA ground-fault protection. The C910-485 can be set to monitor and alarm for high and low temperature, high and low current, ground-fault level, and voltage. Communications modules are available for remote control and configuration.

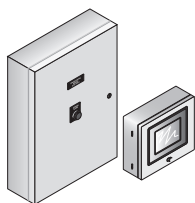

ACS-30
ACS-PCM2-5

The nVent RAYCHEM ACS-30 Advanced Commercial Control System is a multipoint electronic control and monitoring system for heat-tracing used in commercial freeze protection and flow maintenance applications.

The nVent RAYCHEM ACS-30 system can control up to 260 circuits with multiple networked nVent RAYCHEM ACS-PCM2-5 panels. The ACS-PCM2-5 panel can directly control up to 5 individual heat-tracing circuits using electromechanical relays rated at 30 A up to 277 V.

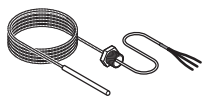

RTDs

Stainless steel jacketed three-wire nVent RAYCHEM RTD (Resistance Temperature Detector) used with nVent RAYCHEM C910-485 and ACS-30 controllers.

RTD-200: 3-in (76 mm) temperature sensor with a 6-ft (1.8 m) lead wire and 1/2-in NPT bushing

RTD10CS: temperature sensor with a 10-ft (3 m) flexible armor, 18-in (457 mm) lead wire and 1/2-inch NPT bushing

RTD50CS: temperature sensor with a 50-ft (3 m) flexible armor, 18-in (457 mm) lead wire and 1/2-in NPT bushing

7

Control, Monitoring and Power Distribution

7.2 Power Distribution

Power to the heating cables can be provided in several ways:

- Directly through the temperature controller
- Through external contactors activated by a temperature controller
- Through a nVent RAYCHEM HTPG power distribution panel

RaySol heating cable circuits that do not exceed the current rating of the selected control can be switched directly (Figure 10). When the total electrical load exceeds the rating of the controller, an external contactor is required. For group control, a single temperature controller may be used to control two or more circuits. Multiple RaySol heating cable circuits may be controlled by a single temperature controller, through a contactor, as shown in Figure 10.

7

Control, Monitoring and Power Distribution

Single circuit control

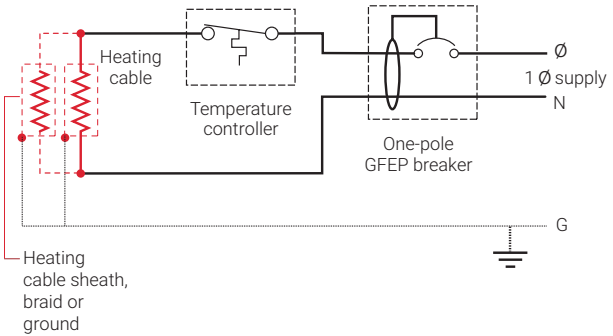

Group control

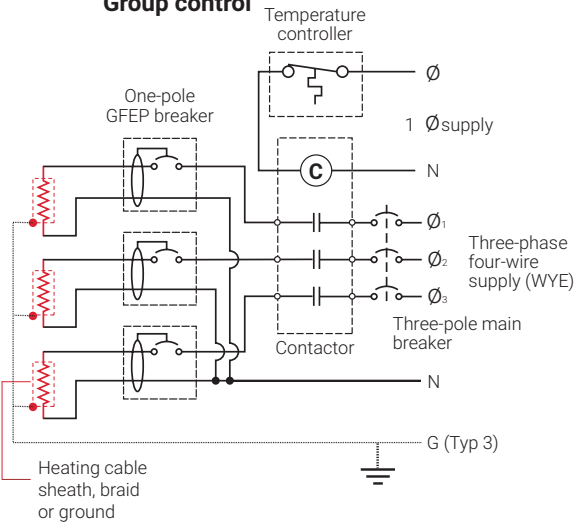

Figure 10: Single circuit and group control

7

Control, Monitoring and Power Distribution

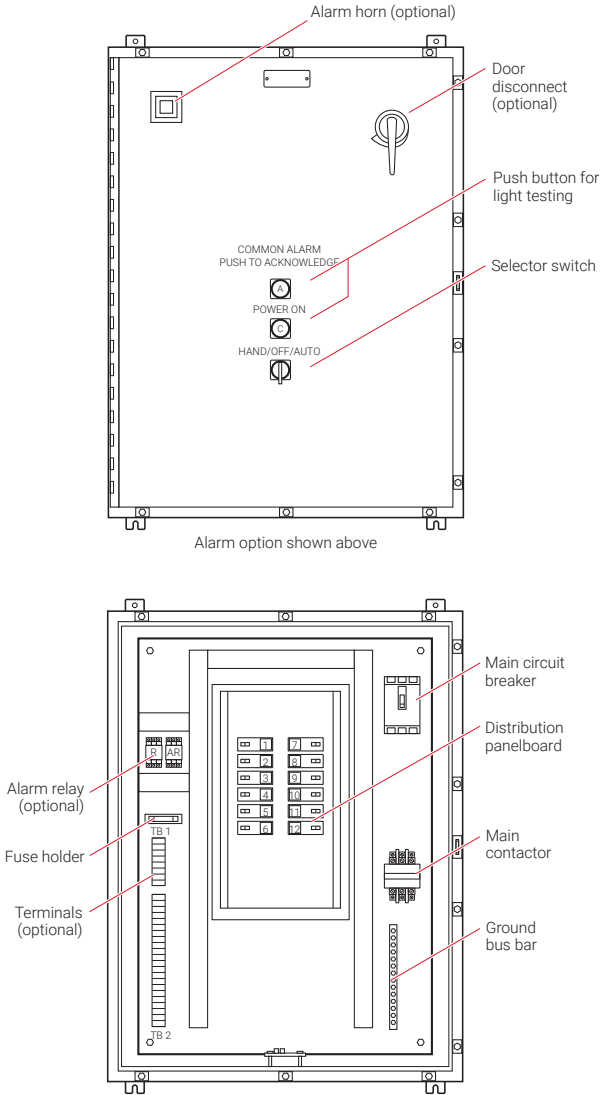

Figure 11: HTPG power distribution panel

7

Control, Monitoring and Power Distribution

Three-phase, four-wire supply (Wye)

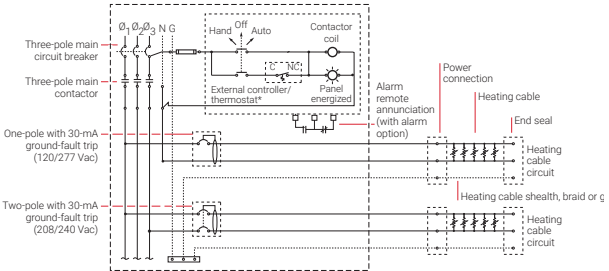
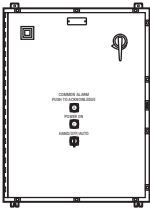

Figure 12: HTPG power schematic

TABLE 4: POWER DISTRIBUTION

Description

Power distribution and control panels



Heat-tracing power distribution panel with ground-fault and monitoring for group control.

HTPG

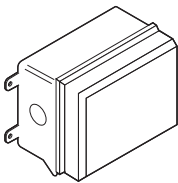

E104

Three-pole, 100 A per pole, 600 V maximum contactor housed in UL Listed, CSA Certified, NEMA 4X enclosure with two 1-inch conduit entries. When ordering, select coil voltage (110-120, 208-240, 277 V).

Enclosure dimensions: 13-1/2 in x 9-1/5 in x 6-11/16 in (343 mm x 234 mm x 170 mm).

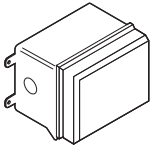

E304

Three-pole, 40 A per pole, 600 V maximum contactor housed in UL Listed, CSA Certified NEMA 4X enclosure with two 1-inch conduit entries. When ordering, select coil voltage (110-120, 208-240, 277 V).

Enclosure dimensions: 9-1/2 in x 7-1/5 in x 6-11/16 in (241 mm x 183 mm x 170 mm).

8

Commissioning and Preventive Maintenance

nVent requires a series of commissioning tests be performed on the RaySol system. These tests are also recommended at regular intervals for preventive maintenance. Results must be recorded and maintained for the life of the system, utilizing the “Installation and Inspection Record” (refer to Section 13). Submit this manual with initial commissioning test results to the owner.

8.1 Tests

A brief description of each test is found below. Detailed test procedures are found in Section 10.

Visual Inspection Test

Visually inspect the floor, conduit, insulation, and connections to the heating cable for physical damage. Check that no moisture is present, electrical connections are tight and grounded, insulation is dry and sealed, and control and monitoring systems are operational and properly set. Damaged heating cable must be replaced.

Insulation Resistance Test

Insulation Resistance (IR) testing is used to verify the integrity of the heating cable inner and outer jackets. IR testing is analogous to pressure testing a pipe and detects if a hole exists in the jacket.

Ground-Fault Test

Test all ground-fault breakers per manufacturer’s instructions.

Circuit Length Verification (Capacitance Test)

The installed circuit length is verified through a capacitance measurement of the RaySol heating cable. Compare the calculated installed length against the system design. If the calculated length is shorter than the system design, confirm all connections are secure and the grounding braid is continuous.

9

Test Procedures

9.1

System Tests

The following tests must be done after installing the connection kits:

1. Visual inspection
2. Insulation resistance test
3. Circuit length verification (Capacitance test)
4. Power test

If the cables are directly embedded in mortar or concrete, the heating cable must be continuously meggered during the concrete pour.



Important: Allow for setting-bed expansion. If the floor tiles are constrained, they will crack or pop loose when the heating cable is energized. Therefore, be sure to allow a ½ in (1.3 cm) gap between the tile's edge and all room walls.



Important: When installing RaySol in mortar or concrete, the heating cable must be continuously meggered during the concrete pour. The commissioning records shall contain the name and location of the installation, data of commissioning, commissioning person signature and must be retained by the end customer and nVent.

Visual Inspection Test

- Check all power connections and splice kits for proper installation, overheating, corrosion, moisture, or loose connections.
- Check the electrical connections to ensure that ground and bus wires are insulated over their full length.
- Check the controller for proper setpoint and operation. Refer to its installation and operation manual for details.

9

Test Procedures

Insulation Resistance Test

FREQUENCY

Insulation resistance testing is required during the installation process and as part of regularly scheduled maintenance, as follows:

- Upon receipt of heating cable
- Prior to installation
- After splice kits, terminations or end seals are installed
- Continuously during concrete pour (if directly embedding cable)
- After concrete pour is complete (if directly embedding cable)
- After any structural work or maintenance is performed on concrete in application area
- As part of scheduled maintenance

PROCEDURE

Insulation resistance testing (using a megohmmeter) should be conducted at three voltages: 500, 1000, and 2500 Vdc. Potential problems may not be detected if testing is done only at 500 and 1000 V. Measure the resistance between the heating cable bus wires and the braid. Do not allow test leads to touch junction box, which can cause inaccurate readings.



Important: System tests and regular maintenance procedures require that insulation resistance testing be performed. Test directly from the controller or the junction box closest to the power connection.

INSULATION RESISTANCE CRITERIA

A clean, dry, properly installed circuit should measure thousands of megohms, regardless of the heating cable length or measuring voltage (500–2500 Vdc).

All insulation resistance values should be greater than 1000 megohms. If the reading is lower, consult Section 11, Troubleshooting Guide.

9

Test Procedures

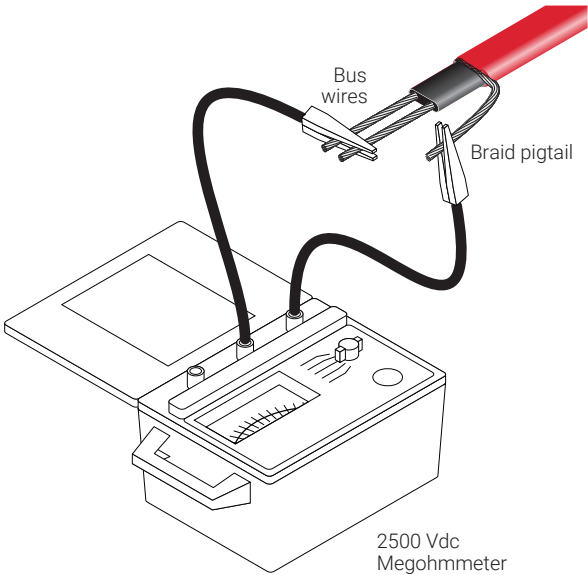

Figure 13: Insulation resistance test

⚠ WARNING: Shock Hazard. The heating cable can store a large electrical charge after the insulation resistance test is performed. To prevent personal injury from electrical shock, fully discharge the cable prior to disconnecting the megohmmeter. The megohmmeter may discharge automatically. However, it may be necessary to short the cable leads. Contact your supervisor or the instrument manufacturer to verify the safest practice.

INSULATION RESISTANCE TEST PROCEDURE

1. De-energize the circuit.
2. Disconnect the controller if installed.
3. Disconnect bus wires from terminal block.
4. Set test voltage at 0 Vdc.
5. Connect the negative (-) lead to the heating cable metallic braid.

9

Test Procedures

6. Connect the positive (+) lead to both heating cable bus wires.
7. Turn on the megohmmeter and set the voltage to 500 Vdc; apply the voltage for one minute. Meter needle should stop moving. Rapid deflection indicates a short. Record the insulation resistance value in the Inspection Record.
8. Repeat Steps 4–7 at 1000 and 2500 Vdc.
9. Turn off the megohmmeter.
10. If the megohmmeter does not self-discharge, discharge phase connection to ground with a suitable grounding rod. Disconnect the megohmmeter.
11. Reconnect bus wires to terminal block.
12. Reconnect the controller.

Circuit Length Verification (Capacitance Test)

Connect the capacitance meter negative lead to both bus wires and the positive lead to the braid wire. Set the meter to the 200 nF range. Multiply this reading by the capacitance factor for the correct heating cable shown below to determine the total circuit length.

$$\text{Length (ft or m)} = \frac{\text{Capacitance (nF)}}{\text{Capacitance factor (ft/nF or m/nF)}}$$

TABLE 5: CAPACITANCE FACTORS

Heating cable	Capacitance factor	
	ft/nF	(m/nF)
RaySol	5.0	(1.6)

Compare the calculated circuit length to the design drawings and circuit breaker sizing tables.



Figure 14: Capacitance test

9

Test Procedures

In Conduit

If physical damage is found, the complete circuit should be removed and replaced with new RaySol heating cable. Do not attempt to repair damaged heating cable.

9.2 Fault Location Tests

There are three methods used for finding a fault within a section of heating cable.

1. Ratio method
2. Conductance method
3. Capacitance method

Ratio Method

The ratio method uses resistance measurements taken at each end of the heating cable to approximate the location of a bus wire short. A shorted heating cable could result in a tripped circuit breaker. If the resistance can be read on a standard ohm meter this method can also be used to find a fault from a bus wire to the ground braid. This type of short would trip a GFPD and show a failed insulation resistance reading. Measure the bus-to-bus heating cable resistance at each end (measurement A and measurement B) of the suspected section.

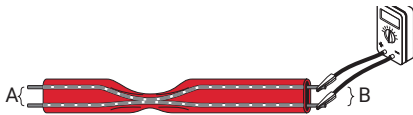

Figure 15: Heating cable resistance measurement test

The approximate location of the fault, expressed as a percentage of the heating cable length from the front end, is:

$$\text{Fault location: } D = \frac{A}{(A + B)} \times 100$$

Example: A = 1.2 ohms
B = 1.8 ohms

$$\text{Fault location: } D = \frac{1.2}{(1.2 + 1.8)} \times 100 = 40\%$$

9

Test Procedures

To locate a low resistance ground fault, measure between bus and braid.



Figure 16: Low resistance ground-fault test

The approximate location of the fault, expressed as a percentage of the heating cable length from the front end, is:

$$\text{Fault location: } D = \frac{A}{(A + B)} \times 100$$

Example: A = 1.2 ohms
 B = 1.8 ohms

$$\begin{aligned} \text{Fault location: } D &= 1.2 / (1.2 + 1.8) \times 100 \\ &= 40\% \end{aligned}$$

The fault is located 40% into the circuit as measured from the front end.

Conductance Method

The conductance method uses the core resistance of the heating cable to approximate the location of a fault when the heating cable has been severed and the bus wires have not been shorted together. A severed heating cable may not trip the circuit breaker. Measure the bus-to-bus heating cable resistance at each end (measurement A and measurement B) of the suspect section. Since self-regulating heating cables are a parallel resistance, the ratio calculations must be made using the conductance of the heating cable.



Figure 17: Heating cable resistance measurement

9

Test Procedures

The approximate location of the fault, expressed as a percentage of the heating cable length from the front end, is:

$$\text{Fault location: } D = \frac{1/A}{(1/A + 1/B)} \times 100$$

Example: A = 100 ohms
 B = 25 ohms

$$\begin{aligned} \text{Fault location: } D &= (1/100) / (1/100 + 1/25) \times 100 \\ &= 20\% \end{aligned}$$

The fault is located 20% from the front end of the circuit.

Capacitance Method

This method uses capacitance measurement (nF) as described on page 31, to approximate the location of a fault where the heating cable has been severed or a connection kit has not been connected.

Record the capacitance reading from one end of the heating cable. The capacitance reading should be measured between both bus wires twisted together (positive lead) and the braid (negative lead). Multiply the measured capacitance with the heating cable's capacitance factor as listed in the following example:

Example: RaySol = 16.2 nF

Capacitance factor = 5.0 ft/nF

Fault location = 16.2 nF x 5.0 ft/nF = 81 ft (24.7 m)

The ratio of one capacitance value taken from one end (A) divided by the sum of both A and B (A + B) and then multiplied by 100 yields the distance from the first end, expressed as a percentage of the total heating cable circuit length. See Table 5 on page 32, for capacitance factors.

$$\text{Fault location: } C = \frac{A}{(A + B)} \times 100$$

10

Troubleshooting Guide

 **WARNING: Fire Hazard.** A ground-fault alarm may mean the heating cable has been damaged or improperly installed and must not be ignored. Sustained electrical arcing or fire can result. To minimize the risk of fire if the alarm is triggered, shut off the power and repair the system immediately.

Symptom	Probable Causes
Circuit breaker trips	<p>Circuit breaker is undersized</p> <p>Connections and/or splices are shorting out.</p> <p>Physical damage to heating cable is causing a direct short.</p> <p>Bus wires are shorted at the end.</p> <p>Circuit lengths too long.</p> <p>Nick or cut exists in heating cable or power feed wire with moisture present or moisture in connections.</p> <p>GFPD is undersized (5 mA used instead of 30 mA) or miswired.</p>
Low or inconsistent insulation resistance	<p>Nicks or cuts in the heating cable.</p> <p>Short between the braid and heating cable core.</p> <p>Arcing due to damaged heating cable insulation.</p> <p>Moisture present in the connection kits.</p> <p>Test leads touching the junction box.</p>

10

Troubleshooting Guide

 **WARNING:** Damaged heating cable or components can cause electrical shock, arcing and fire. Do not attempt to repair or energize damaged cable. Remove damaged sections at once and replace them with a new length using the appropriate RaySol splice kit. Replace damaged components.

Corrective Action

Recheck the design for startup temperature and current loads. Do not exceed the maximum circuit length for heating cable used. Replace the circuit breaker if defective or improperly sized.

Visually inspect the connection kits. Replace if necessary.

Check for damage around the valves and any area where there may have been maintenance work. Replace damaged sections of heating cable.

Check the end seal to ensure that bus wires are not shorted. If a dead short is found, the heating cable may have been permanently damaged by excessive current and may need to be replaced.

Separate the circuit into multiple circuits that do not exceed maximum circuit lengths.

Replace the heating cable, as necessary. Dry out and reseal the connection and splices. Using a megohmmeter, retest insulation resistance.

Replace undersized GFPD with 30-mA GFPD. Check the GFPD wiring instructions

If heating cable is not yet insulated, visually inspect the entire length for damage.

Replace damaged heating cable sections.

If moisture is present, dry out the connections and retest. Be sure all conduit entries are sealed, and that condensate in conduit cannot enter power connection boxes. If heating cable core or bus wires are exposed to large quantities of water, replace the heating cable. (Drying the heating cable is not sufficient, as the power output of the heating cable can be significantly reduced.)

Clear the test leads from junction box and restart.

11

Appendix

**TABLE A1 RAYSOL MAXIMUM CIRCUIT LENGTHS
(AT 40°F START-UP TEMPERATURE)**

Maximum circuit length in feet (m)			
	Circuit breaker rating (A)	Cable operating voltage	
		120 V	
Installed in conduit	15	180	(54.9)
	20	240	(73.2)
	30	240	(73.2)
	40	240	(73.2)
Surface mounted	15	120	(36.6)
	20	160	(48.8)
	30	240	(73.2)
	40	240	(73.2)
Embedded in concrete or mortar	15	80	(24.4)
	20	105	(32.0)
	30	160	(48.8)
	40	170	(51.8)

**TABLE A2 RAYSOL MAXIMUM CURRENT DRAW
(AT 40°F START-UP TEMPERATURE)**

	120 V		208 V	
	A/ft	A/m	A/ft	A/m
Installed in conduit	0.067	0.219	0.039	0.128
Surface mounted	0.100	0.328	0.058	0.191
Embedded in concrete or mortar	0.152	0.500	0.086	0.284

11

Appendix

208 V		240 V		277 V	
305	(93.0)	335	(102.1)	375	(114.3)
410	(125.0)	450	(137.2)	500	(152.4)
410	(125.0)	450	(137.2)	500	(152.4)
410	(125.0)	450	(137.2)	500	(152.4)
205	(62.5)	210	(64.0)	215	(65.5)
275	(83.8)	285	(86.9)	290	(88.4)
410	(125.0)	425	(129.5)	430	(131.1)
410	(125.0)	425	(129.5)	430	(131.1)
135	(41.1)	140	(42.7)	145	(44.2)
185	(56.4)	185	(56.4)	195	(59.4)
275	(85.3)	280	(85.3)	290	(88.4)
280	(97.5)	320	(97.5)	360	(109.7)

240 V		277 V	
A/ft	A/m	A/ft	A/m
0.036	0.117	0.032	0.105
0.056	0.184	0.055	0.181
0.086	0.284	0.082	0.269

12

Installation and Inspection Records

INSTALLATION AND INSPECTION RECORD: RAYSOL HEAT LOSS REPLACEMENT AND FREEZER FROST HEAVE PREVENTION

Facility _____
Test Date: _____
Circuit number: _____
Heating cable type: _____
Installation method (circle one): Attached to the bottom of floor
Controllers: _____
Temperature setting: _____
Circuit length: _____

Commission

Inspection date:

Visual inspection

Confirm 30-mA ground-fault device (proper rating/function)*

Visual inspection inside connection boxes for overheating, corrosion, moisture, and other problems.

Proper electrical connection, ground, and bus wires insulated over full length

Damaged or missing thermal insulation; damaged, missing, cracked lagging or weatherproofing.

Covered end seals, splices, and tees properly labeled on insulation.

Check controllers for moisture, corrosion, setpoint, switch operation.

Circuit labels attached and located in junction box.

Insulation resistance test

Bus to braid

Upon receipt of cable

After cable is laid out

After all terminations are made

Continuously measured during concrete pour (if directly embedding cable)

After concrete pour is complete (if directly embedding cable)

Circuit length verification (Capacitance factor = 5.0 ft/nF)

Capacitance test: Circuit length (ft) = Capacitance (nF) x Capacitance factor (x 3.28 = m)

* or 5-mA ground-fault device where required by code

12

Installation and Inspection Records

Embedded in mortar or concrete

In conduit

M-Ohms

500 Vdc

1000 Vdc

2500 Vdc

North America

Tel +1.800.545.6258

Fax +1.800.527.5703

thermal.info@nvent.com



nVent.com

©2018 nVent. All nVent marks and logos are owned or licensed by nVent Services GmbH or its affiliates. All other trademarks are the property of their respective owners. nVent reserves the right to change specifications without notice.

Raychem-IM-H58138-RaySolHeatLossFreezerFrostHeave-EN-1805