

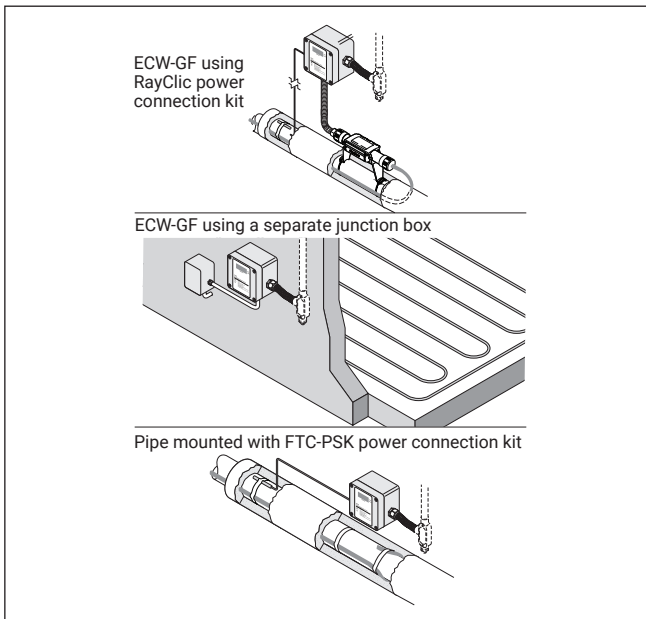

RAYCHEM

ECW-GF

Digital Electronic Controller with Ground Fault Installation Instructions



DESCRIPTION

The nVent RAYCHEM ECW-GF is an electronic ambient, pipe, or slab sensing controller with 30-mA ground-fault protection. It is ideal for pipe freeze protection, flow maintenance, freezer frost heave and snow melting applications. The controller can be programmed to maintain temperatures up to 200°F (93°C) at voltages from 100 to 277 V and can switch current up to 30 Amperes. The ECW-GF is complete with a 25-ft (7.6-m) temperature sensor and is housed in a NEMA 4X rated enclosure. The controller features an AC/DC dry alarm contact relay for monitoring critical applications such as fire protection piping. The controller may be wall mounted or pipe mounted with the optional FTC-PSK kit.

An optional ground-fault display panel (ECW-GF-DP) can be added to provide ground-fault or alarm indication in applications where the controller is mounted in inaccessible locations.

For technical support call nVent at 800-545-6258.

TOOLS REQUIRED

- Large slotted screwdriver
- Needle nose pliers
- Small slotted screwdriver
- Wire strippers

ADDITIONAL MATERIALS REQUIRED

(NOT PROVIDED IN THIS KIT)

- Optional remote ground-fault and heating operation display panel (Catalog No. ECW-GF-DP)
- Appropriate mounting fasteners or optional pipe mount kit (Catalog No. FTC-PSK)

APPROVALS

Nonhazardous Locations



KIT CONTENTS

Item	Qty	Description
A	1	Lid
B	1	Wire cover
C	1	Box with electronics
D	1	25 ft thermistor
E	1	1/2 inch compression gland
F	1	Battery connector

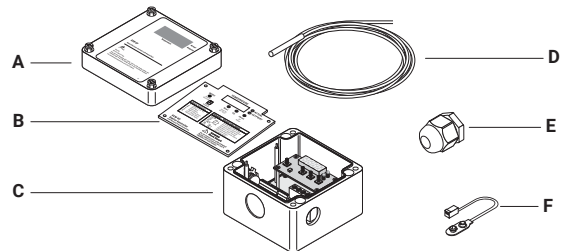

⚠ WARNING:

This component is an electrical device that must be installed correctly to ensure proper operation and to prevent shock or fire. Read these important warnings and carefully follow all the installation instructions.

- To minimize the danger of fire from sustained electrical arcing if the heating cable is damaged or improperly installed, and to comply with the requirements of nVent, agency certifications, and national electrical codes, ground-fault equipment protection must be used. Arcing may

not be stopped by conventional circuit breakers. The ECW-GF provides the required ground-fault equipment protection.

- The ECW-GF must be effectively grounded to ensure proper operation. Do not rely on the conduit system to provide a ground path. Use the grounding terminals/screws to connect to system ground leads.
- Component approvals and performance are based on the use of nVent-specified parts only. Do not use substitute parts or vinyl electrical tape.

- The black heating cable core is conductive and can short. They must be properly insulated and kept dry.
- Damaged bus wires can overheat or short. Do not break bus wire strands when scoring the jacket or core.
- Keep components and heating cable ends dry before and during installation.
- Use only fire resistant insulation materials, such as fiberglass wrap or flame-retardant foam.

Wall mounting the ECW-GF controller

1

- Attach box to wall using the appropriate mounting fasteners.

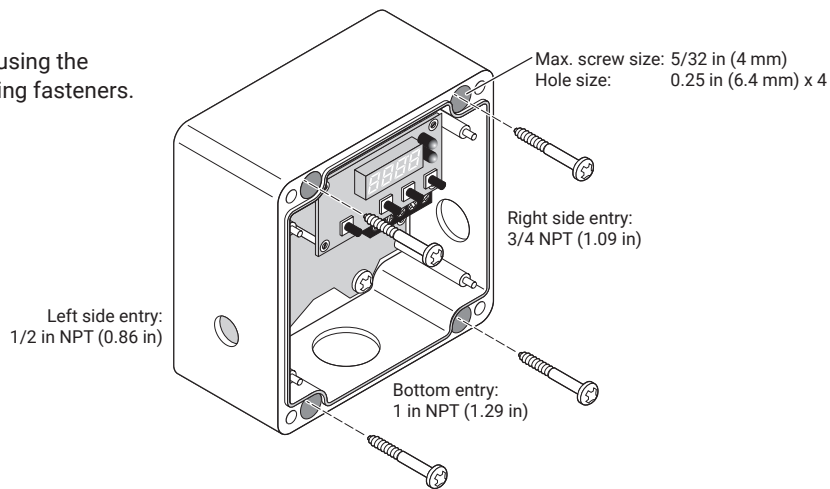

2A

Heating cable directly connected to the ECW-GF controller

- Insert the two heating cable power wires from the heating cable's junction box into the terminal block marked "To Heating Cable" and the ground (braid) marked "Earth" and tighten terminals. Confirm connection by pulling on the wires.
- For directly connected MI cable, you must use a 1 to 1/2 inch reducing bushing with grounding hub.

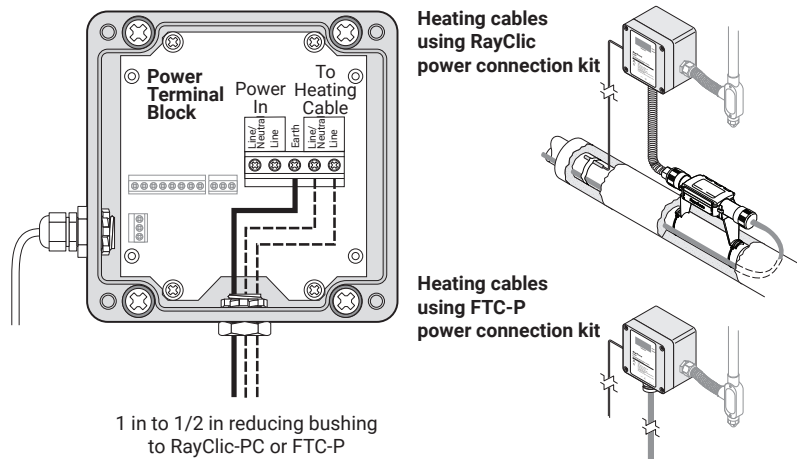

2B

Connecting heating cable using a separate junction box

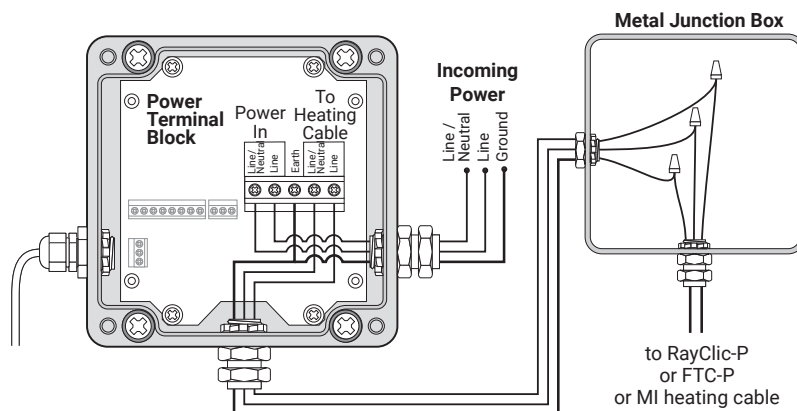

Mounting the RAYCHEM ECW-GF controller directly on the pipe using the optional FTC-PSK pipe stand kit

1

Note: Prepare the heating cable in the stand following the instructions included in the nVent RAYCHEM FTC-PSK kit.

- Fasten stand to pipe with label facing desired direction of box opening. Do not pinch heating cable.
- Loop and tape extra heating cable to pipe.

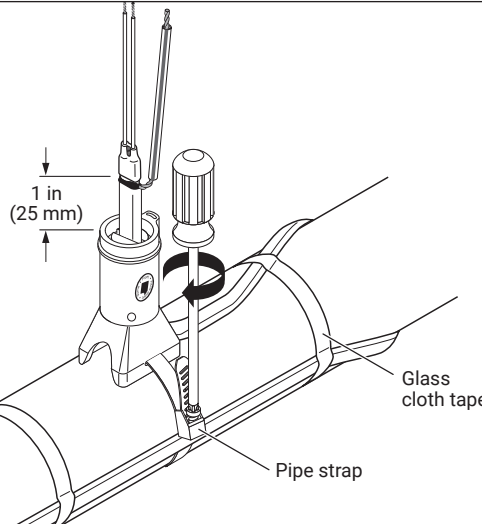

Note: For 1 in (25 mm) and smaller pipes use adapter (purchased separately) and install between stand and pipe.

JBS-SPA adapter for small pipes

Position adapter this side up.

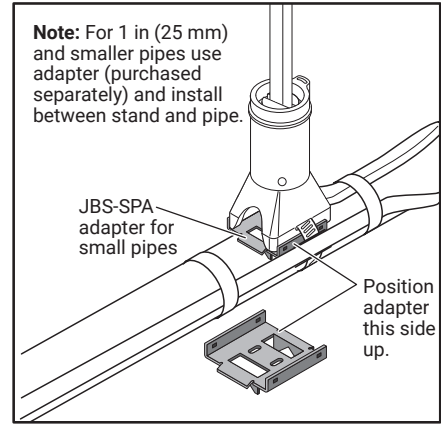

2

- Screw transition onto stand until it stops. Tighten until slots on transition and stand align. Do not damage threads on transition.

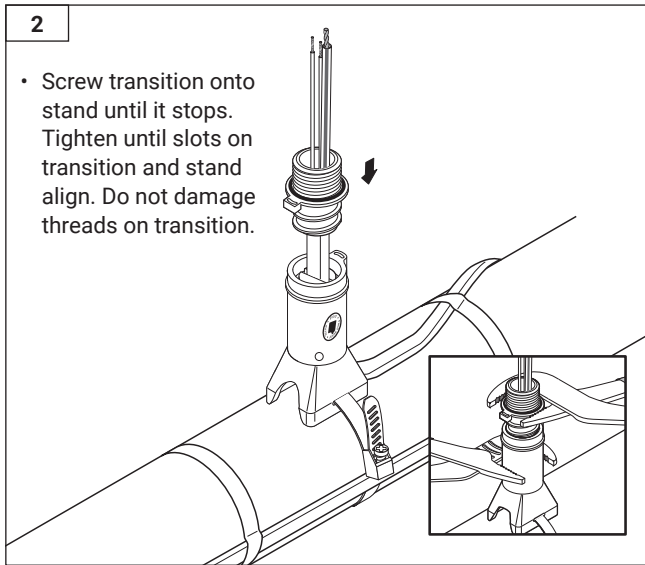

3

- Insert cable tie through slots on stand and transition and tighten firmly to prevent transition rotation.
- Trim off extra cable tie.

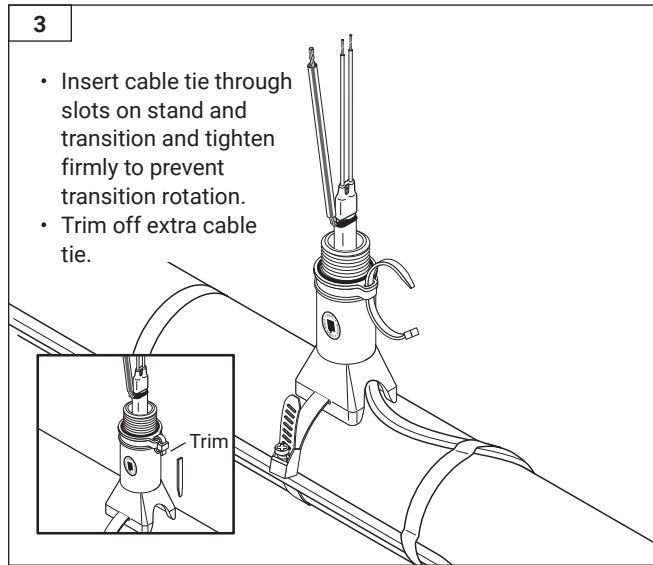

4

- Make sure o-ring is seated in groove on transition.
- Place box onto transition and install locknut.
- Tighten locknut.

O-ring

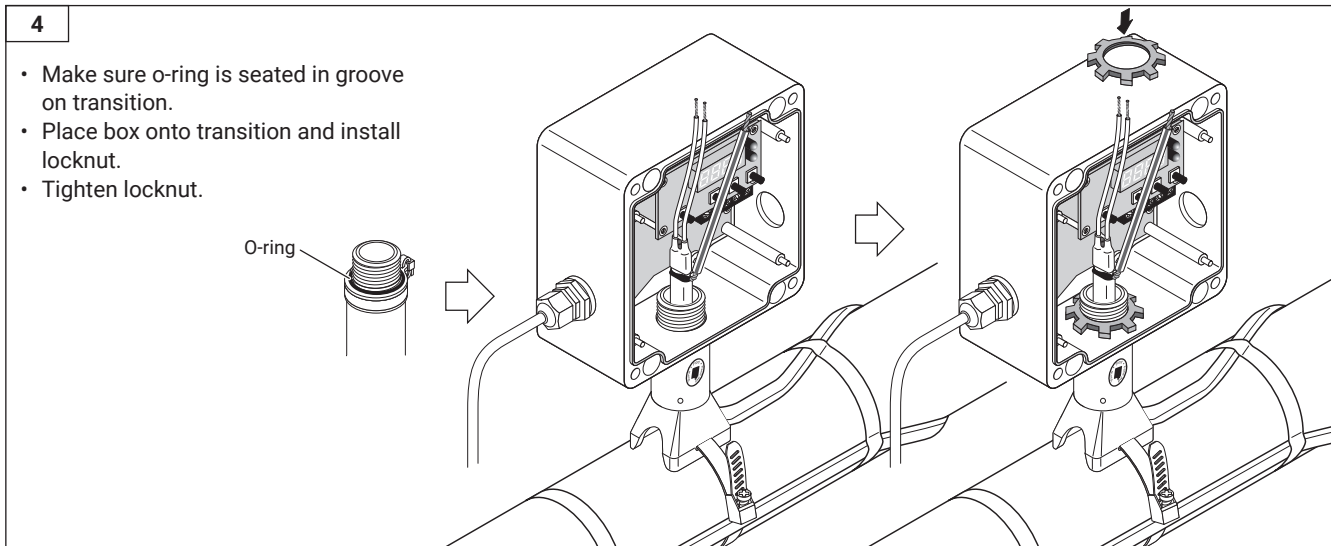

Connecting Power, Temp Sensor, Alarm and Remote Display Panel

1

Connecting Incoming Power

- Install conduit and fittings as shown. To minimize loosening due to pipe vibration, use flexible conduit.
- Pull in power and ground wires, strip off 1/2 in (13 mm) of insulation and terminate.
- Confirm by pulling on the wires.

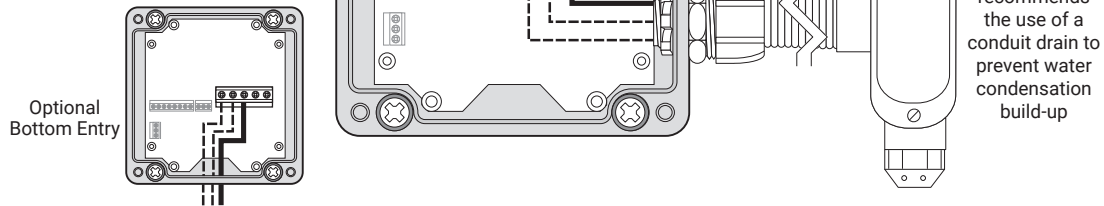

2

Connecting Temperature Sensor

- Adjust the length of the temperature sensor to meet the application needs and strip the sensor wires leaving 3 in to make the connections. Strip 1/2 in if insulation from the wires to insert into the terminal blocks.
- Insert the three temperature sensor wires into the terminal block marked "J5." Place the white wire into T1, the black wire into T2 and the shield wire into SH, and tighten terminals. Confirm connection by pulling on the wires.

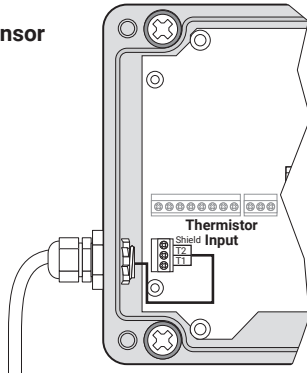

3

Connecting Alarm

- The controller has a form C contact for remote enunciation of temperature sensor failure and low/high temperature alarms. If an external alarm is required, then alarm wiring can exit the enclosure via the 3/4 in power conduit hole as long as the insulation rating of the alarm wire is equal to the power wire.

Normally energized; changes state upon an alarm.

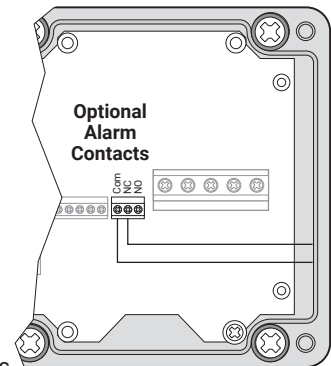

4

- Screw transition onto stand until it stops. Tighten until slots on transition and stand align. Do not damage threads on transition.

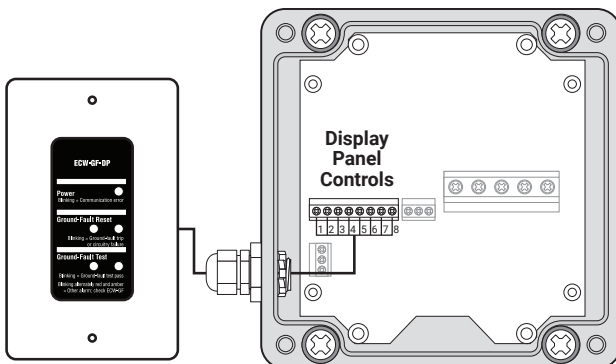

5

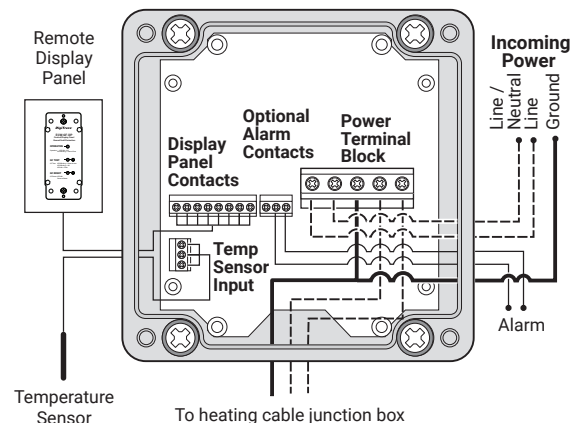

6

- Install wire cover by attaching it to plastic stand-offs.
- Program the controller. (See the section “Programming the Controller” that follows.)
- Install lid.
- Leave these instructions with the end user for future reference.

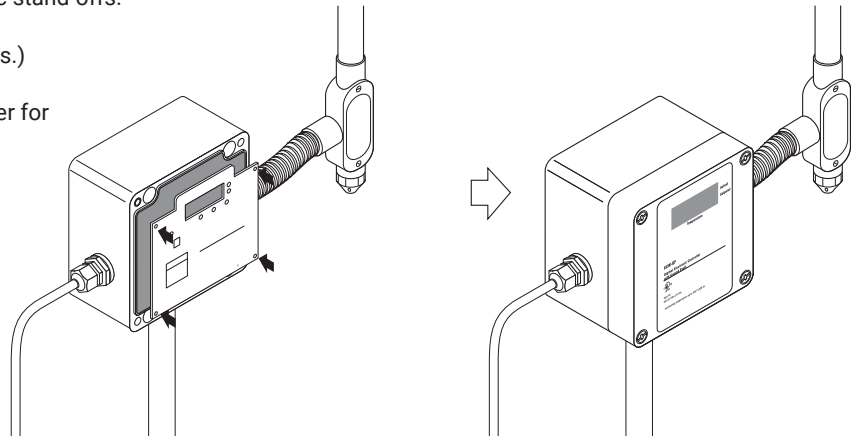

Programming the Controller To program the controller, supply voltage to the controller in either of the following ways.

1A

Powering Controller via Battery

(This option allows programming the controller prior to powering the heating cable and controller circuit.)

- Connect 9 Vdc battery (not provided) to the supplied battery connector.
- Plug the battery connector onto the two pins on the controller marked “Battery Connector.”

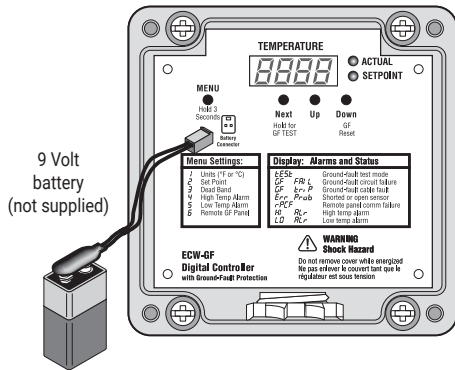

1B

Powering Controller via Line Power

⚠ WARNING: Shock Hazard. Secure the wire cover in place with the four screws before energizing circuit.

- Turn on branch circuit breaker that supplies power to the controller and heating cable.

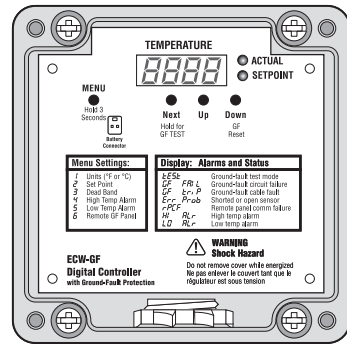

2

Activating and Navigating the Menu in Set-up Mode

- To activate set-up mode, press **Menu** button for approximately 3 seconds.
- The display will change to the default mode for units.
- Use the **Up** and **Down** buttons to change values.
- Use the **Next** button to change to next display code/parameter.
- When completed, secure the enclosure cover.

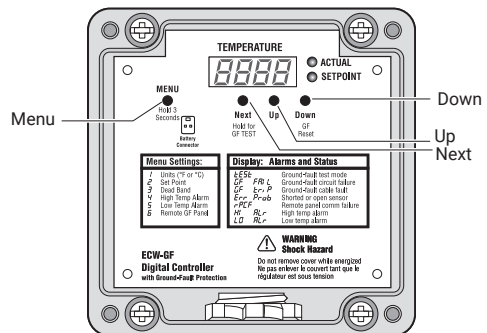

Menu Settings

The first parameter displayed during set-up mode is units (°F or °C). Other parameters, their default values, and minimum and maximum values are shown in the following table.

Menu Items	Parameter	Default	Min.	Max.
1	Units (°F or °C)	°F	-	-
2	Maintain set point	40°F (4°C)	32°F (0°C)	200°F (93°C)
3	Deadband	5°F (3°C)	2°F (2°C)	10°F (6°C)
4	High Alarm	Off	Set point plus deadband +5°F (3°C)	230°F (110°C)
5	Low Alarm	Off	20°F (-7°C)	Set point minus deadband
6	Remote G-F panel Enable (On or Off)	Off	-	-

Display and Operation

In operation the display will alternate between temperature setpoint and true time measured temperature.

Alarm Relay
Form C: 2 A at 277 Vac, 2 A at 48 Vdc
Normally energized; changes state upon an alarm or loss of incoming power.

Display and Error Codes	LED Status	Fault
<i>Err Prob</i>	Blinking alternately red and amber LEDs	Shorted or open temperature sensor
<i>Hi ALR</i>	Blinking alternately red and amber LEDs	High Temperature Alarm
<i>Lo ALR</i>	Blinking alternately red and amber LEDs	Low Temperature Alarm
<i>GF Trip</i>	Blinking red LED	Ground-fault trip
<i>GF FAIL</i>	Blinking red LED	Ground-fault circuit fail
<i>rPCF</i>	Blinking alternately red and amber LEDs	Remote ground-fault panel communication failure

NORTH AMERICA

Tel +1.800.545.6258
Fax +1.800.527.5703
thermal.info@nvent.com

EUROPE, MIDDLE EAST, AFRICA

Tel +32.16.213.511
Fax +32.16.213.604
thermal.info@nvent.com

ASIA PACIFIC

Tel +86.21.2412.1688
Fax +86.21.5426.3167
cn.thermal.info@nvent.com

LATIN AMERICA

Tel +1.713.868.4800
Fax +1.713.868.2333
thermal.info@nvent.com



nVent.com