

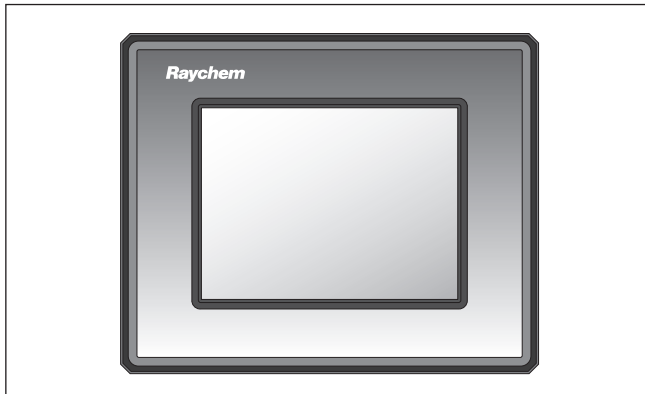

RAYCHEM

NGC-UIT-ORD to NGC-UIT2-ORD

Conversion Instructions



KIT CONTENTS

Qty	Description	Manufacturer	Part Number
2	9 Pin D-Sub to 10 pin terminal block	Phoenix Contact	2315162
1	12 Vdc Power Supply	Lambda	DSP60-12
2	Serial Communication cables, 10 ft.	L-Com	CSMN9MF-10
3	Alarm Relays – 12 V, 12 A, SPDT	TE Connectivity	RTB14012F
3	Alarm Relay Sockets	TE Connectivity	RT78724
1	NGC-UIT2-ORD and mounting hardware (12 Kep nuts, 6/32 in)	nVent	10332-013
1	DIN35 Rail, 10 inches	N/A	
1	Template for replacing UIT1 with UIT2	nVent	
3	Ground Terminal Blocks	Phoenix Contact	3031238
4	End Clamps	Phoenix Contact	0800886
Optional – To be purchased separately – UIT2 Window Kit P/N T1011164			

DESCRIPTION

These instructions will guide the installer on how to convert from nVent RAYCHEM NGC-UIT-ORD to nVent RAYCHEM NGC-UIT2-ORD and are intended only for personnel experienced in panel constructions. This kit can also replace a NGC-UIT-OUT if installed in a nonhazardous area. If installed outdoors in nonhazardous area, then a protective cover is required.

TOOLS REQUIRED

- Masking tape
- #16 (3/16) drill bit
- 3/8 drill bit
- Metal file
- In-line torque wrench with 8mm (5/16 in) socket
- Jig saw (recommend using carbon steel blade with 24TPI)

SPECIFICATIONS

General

Area of Use	Nonhazardous, indoors or outdoors (IP65, Type 4)
Supply Voltage	9 – 30 Vdc, 3.6 – 1.2 A
Operating Temperature	–30°C to 60°C (–22°F to 140°F)
Storage Temperature	–30°C to 80°C (–22°F to 176°F)
Dimensions	279 mm W X 229 mm H X 70 mm D (11 in. W X 9 in. H X 2.75 in. D)

Alarm Outputs

Transistor open collector outputs	Three open collector outputs, with a range of 5 – 30 Vdc with a max. sink current of 500 mA
Use to drive external relays	Relays may be assigned for alarm outputs.

LCD Display

Display	LCD is a 8.4 in. XGA, color TFT transfective device with integral LED backlight
Touch Screen	5-wire resistive touch screen interface for user entry

Network Connection

Local/Remote Port	RS-232/RS-485 ports may be used to communicate with host computers (nVent RAYCHEM Supervisor Software) or DCS
Local RS-232	A non-isolated, 9 pin D sub male
Remote RS-485 #2	2-wire isolated, 9 pin D sub male
Data Rate	9600 to 57600 baud.
Maximum cable length	For RS-485 not to exceed 1200 m (4000 ft). Cable to be shielded twisted pair.
Field Port	RS-485, 2-wire isolated. Used to communicate with external devices, such as NGC-30-CRM and RMM2. Maximum cable length not to exceed 1200 m (4000 ft). Cable to be shielded twisted pair.
Field RS-485 #1	2-wire isolated, 9 pin D sub male
Data Rate	To 9600 baud
LAN	10/100 Base-T Ethernet port with Link and Activity
Status LEDs	USB Ports USB 2.0 Host port Type A receptacle (X2)

⚠ WARNING:

FIRE Hazard: The NGC-UIT2-ORD must not be used in hazardous locations. Electrical components within the unit could ignite flammable gases. Do not install the unit where it may be exposed to flammable gases.

⚠ IMPORTANT:

The NGC-UIT2-ORD is an electronic unit. During installation, take the following precautions to avoid damage to its electronic components.

- Handle with care to avoid mechanical damage.
- Keep electronics dry.
- Avoid exposure to static electricity.

- Avoid contamination with metal filings, liquids, or other foreign matter.
- Take care to protect the user interface board on the enclosure door.
- Use agency-approved conduit bushings, adapters, and cable glands to keep the enclosure protected from dust and fluids.

1 Removing the Existing NGC-UIT-ORD

⚠ CAUTION – Power to the Electrical panel that is housing the NGC-UIT-ORD must be turned OFF before proceeding.

1. Disconnect the cables from the NGC-UIT-ORD by loosening the retaining screws that secure the Phoenix connectors to the mating terminals on the NGC-UIT-ORD. This includes the serial communications (RS-485), Relay outputs and AC Input.

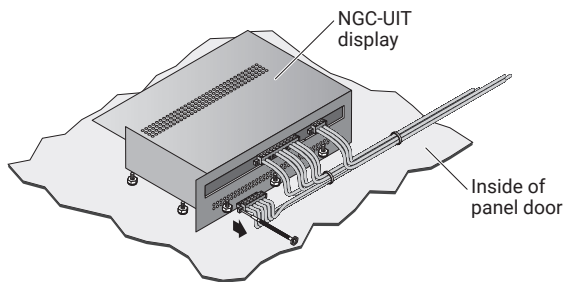

2 Removing the Existing NGC-UIT-ORD

1. Loosen and remove all 10 screws and remove the NGC-UIT-ORD from the panel door.

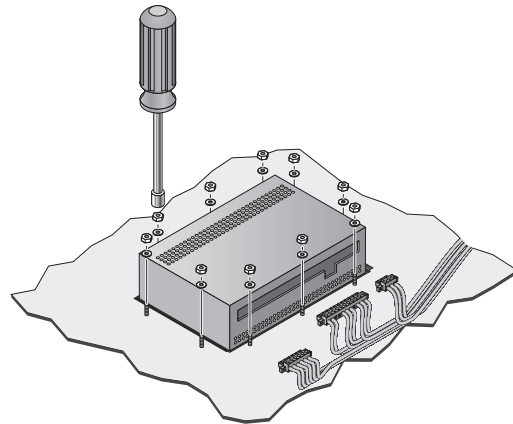

3 Removing the Existing NGC-UIT-ORD

1. Disconnect the wires from the Phoenix connectors. Undo all the cable ties for the wiring bundle to the NGC-UIT-ORD. These wires will be used for the NGC-UIT2-ORD once it is installed.

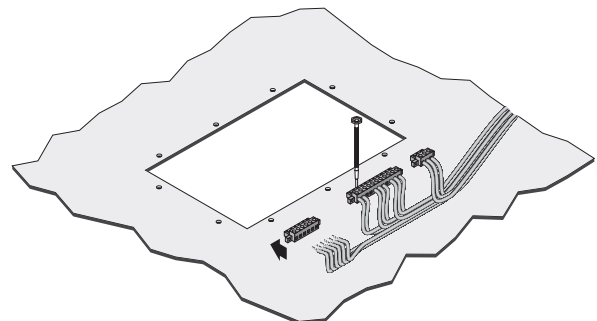
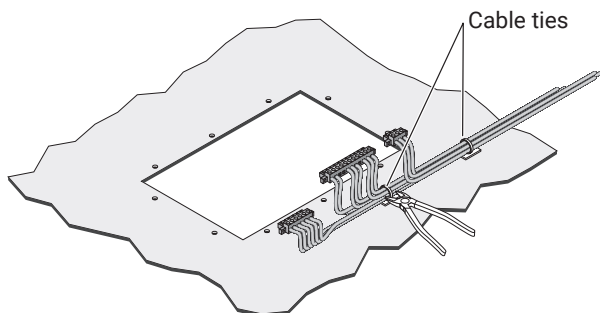

Enlarging the NGC-UIT opening

Use the foldout template as the guide for enlarging the cutout.

Template is actual size (see attached at back of booklet)

Instructions

1. Line up the upper left hand corner of the template with the existing cutout. Use masking tape to secure the template to the panel door. The dashed lines indicate the areas that must be removed.
2. Using a center punch, mark the 12 mounting holes, M1–M12.
3. Using a center punch, mark the 3 holes used to insert a cutting blade, H1–H3.
4. After making the marks using the center punch, remove the template.
5. Using a straight edge and marking pen, draw a line starting from the upper left hand corner to the center of hole H1. Repeat the line from the center of hole H1 to H2 and H3.
6. Use a 3/16 drill bit and drill all 12 mounting holes, M1–M12.
7. Use a 3/8 drill bit and drill the 3 holes used to insert the cutting blade, H1–H3.
8. Using a jigsaw start the cut from the bottom left corner of the existing cutout and follow the marked line to the center of hole H1. Continue the cut to hole H2 and H3. End the cut at the upper right hand corner of the existing cutout.
9. Debur all cut edges before installing the new UIT2.

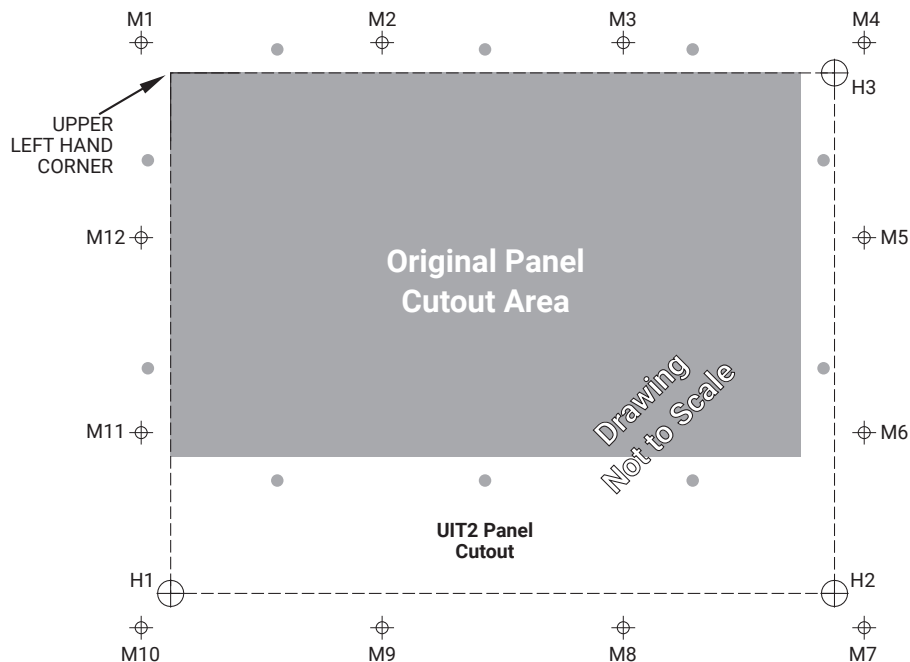
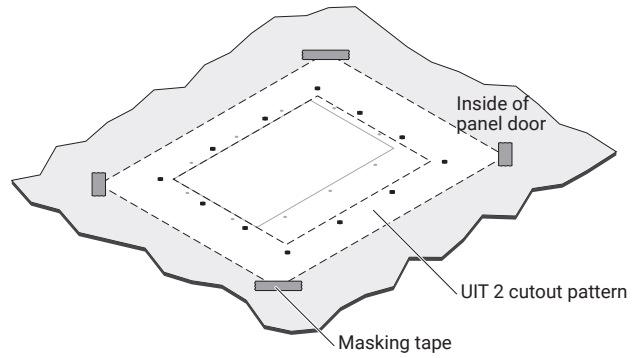

Installing the NGC-UIT2-ORD

1. Insert the NGC-UIT2-ORD into the panel door opening. Verify that the gasket that came with the NGC-UIT2-ORD is properly installed. Secure the UIT2 using the twelve 8-32 nuts and hardware.
2. After the display is properly positioned, tighten the nuts to 0.9 newton-meters (8-inch-pounds) of torque using a 8mm (5/16 in) wrench. Tighten Kep nuts in the sequence shown for proper sealing.

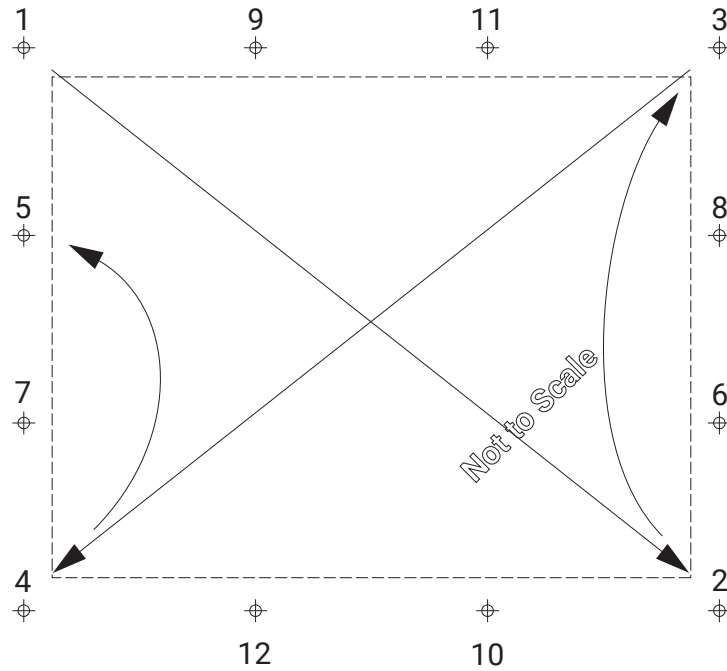

Installing the DIN Rail components

1. Locate an area in the panel where the components mounted on the DIN rail can be installed. If there is DIN rail space available then mount these on components on the available space.

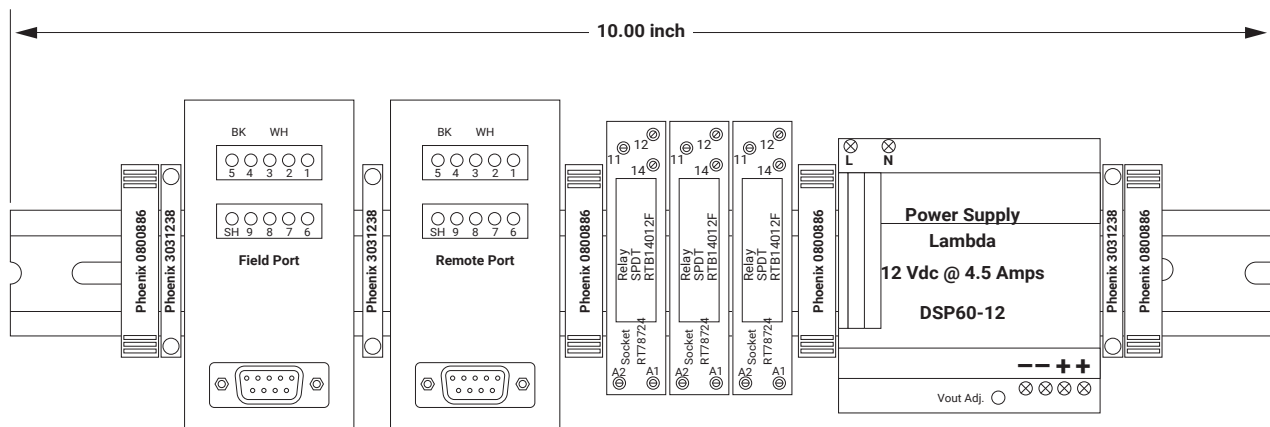

Connect Power

1. Connect the AC voltage wires that were removed from the NGC-UIT to the AC input on the 12V power supply. Refer to wiring diagram below. The illustration below shows the wires from the UIT1 (dashed lines) going to the power supply AC input.
2. Connect the DC side of the power supply to the UIT2 DC input, one side of the alarm relays and DC input to the alarm relay driver outputs.

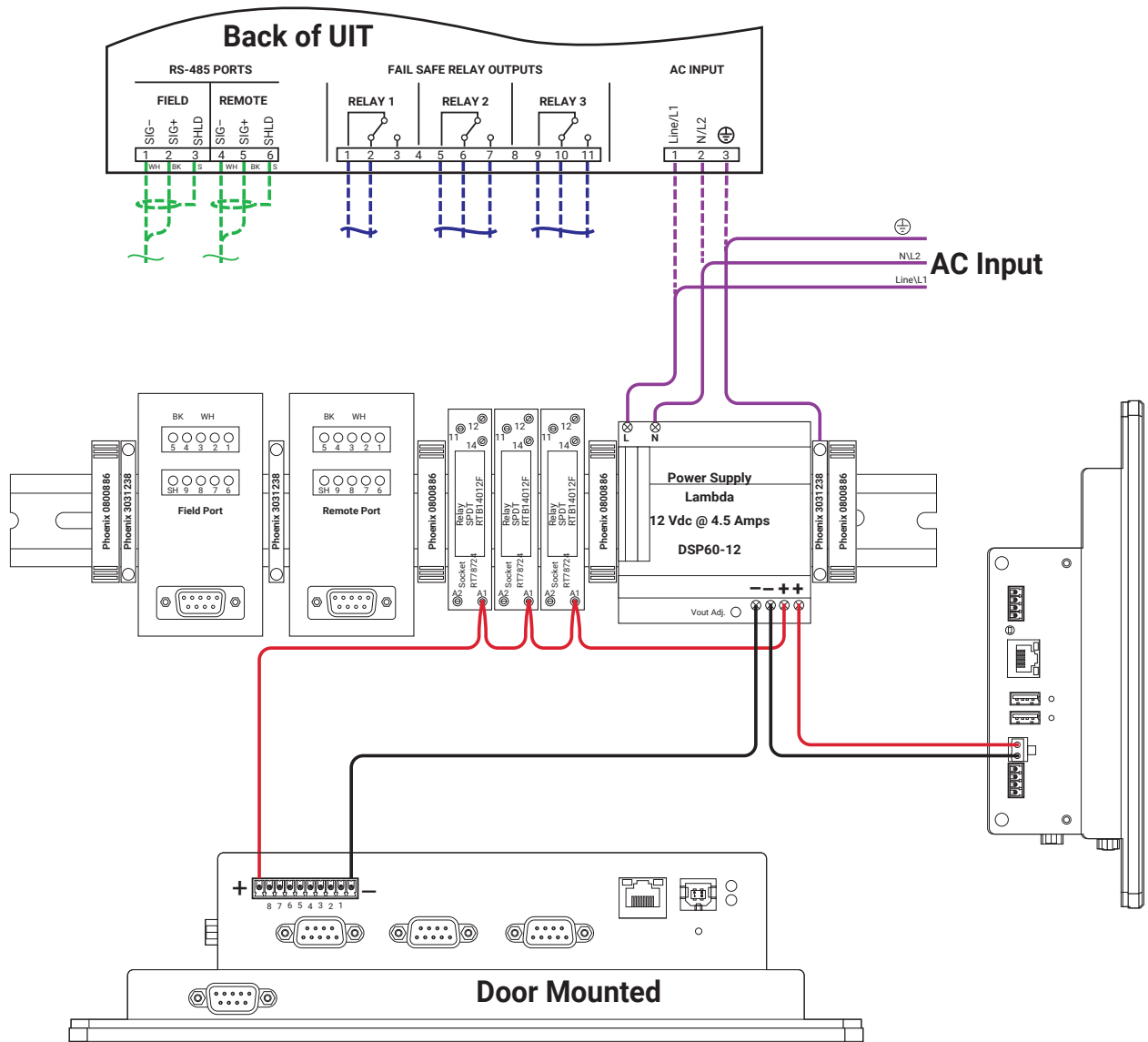

Connecting the Alarm Relays

1. The illustration below shows the wiring for the alarm relays from UIT1 (dashed lines) to UIT2. TB-X's are the field terminals. Refer to the panel wiring for location of the field terminals.
2. Connect the Relay Driver Output signals to the relays shown in the illustration below.

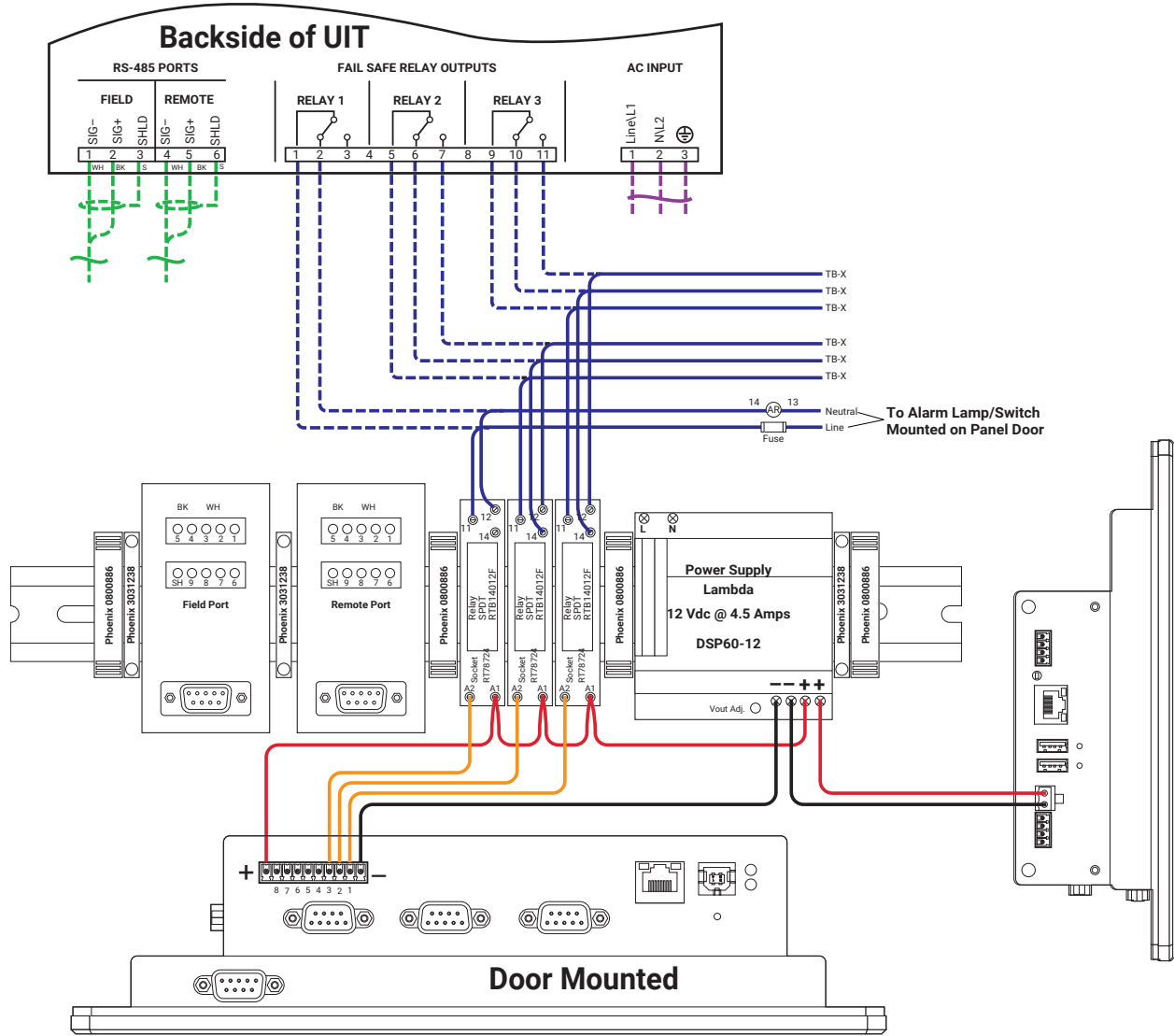

Communications

1. The illustration below shows the wiring for RS-485 ports from UIT1 (dashed lines) to UIT2. Refer to the panel wiring for location of the field terminals.
2. Connect the RS-485 serial cables to the appropriate comm port on the UIT2 as shown in the illustration.

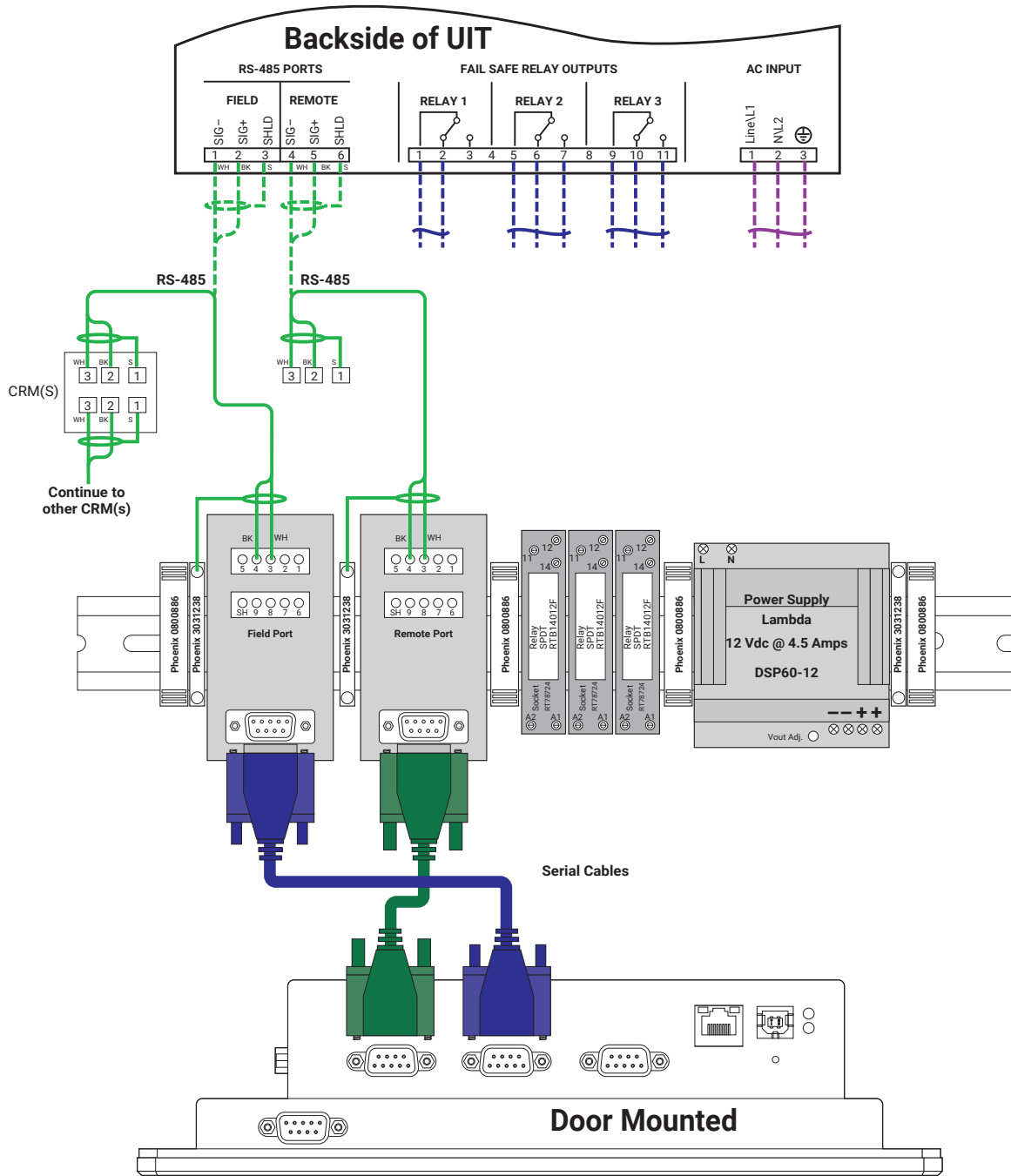

NGC-UIT2-HAZ Cut Out Dimensions

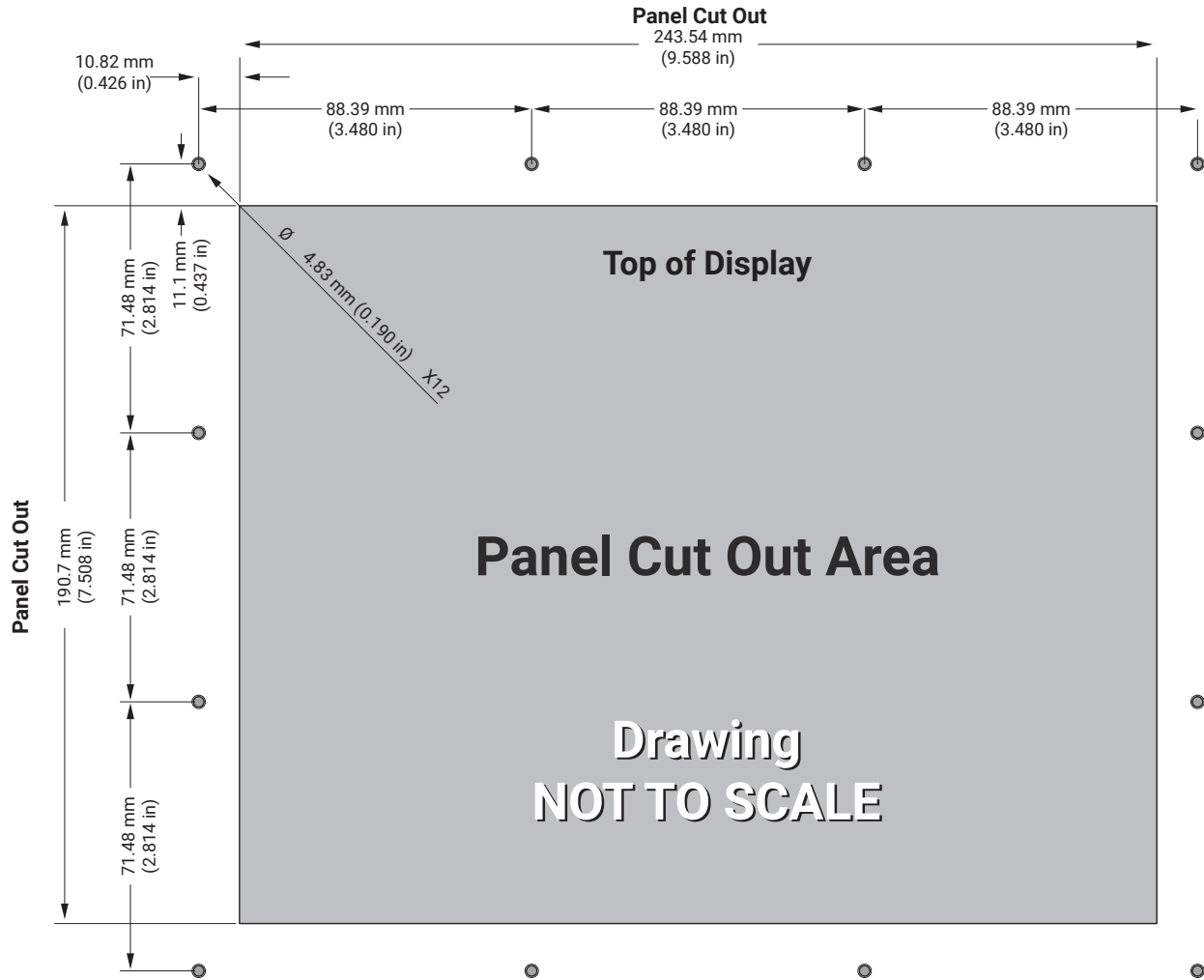

North America

Tel +1.800.545.6258
 Fax +1.800.527.5703
 thermal.info@nvent.com

Europe, Middle East, Africa

Tel +32.16.213.511
 Fax +32.16.213.604
 thermal.info@nvent.com

Asia Pacific

Tel +86.21.2412.1688
 Fax +86.21.5426.3167
 cn.thermal.info@nvent.com

Latin America

Tel +1.713.868.4800
 Fax +1.713.868.2333
 thermal.info@nvent.com



nVent.com