

TT-FLAT PROBE

CONNECT AND PROTECT

Water leak detection probe

PRODUCT OVERVIEW

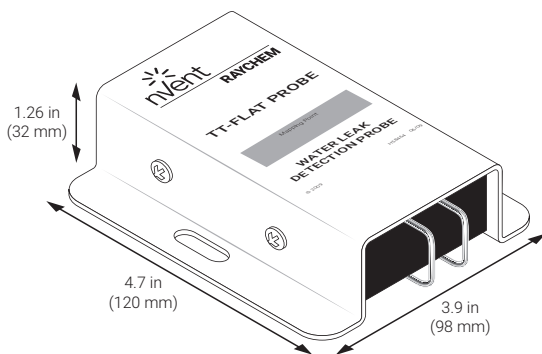

The nVent RAYCHEM TraceTek TT-FLAT PROBE is a special purpose probe designed to detect water leaks in specific locations. It is intended to be floor or tray mounted, using either screw or adhesive attachment. The unit has an orange color to promote visibility in the installed location.

The TT-FLAT PROBE can detect water leaks in low spots, drip trays or sumps, where nVent RAYCHEM TraceTek sensing cables are inappropriate. The TT-FLAT PROBE is designed to be integrated as a part of a larger nVent RAYCHEM TraceTek leak detection system.

The TT-FLAT PROBE can be interconnected with jumper cable to other TT-FLAT PROBE or nVent RAYCHEM TraceTek sensing cable segments, and be monitored by a nVent RAYCHEM TraceTek TT-TS12 panel, TTDM-128 or TT-SIM module.

Simple and easy to use

The TT-FLAT PROBE is compatible with all nVent RAYCHEM TraceTek TT1000 system components.

The leak detection system design is very flexible with the TT-FLAT PROBE and leak detection cable.

The illustration below shows several possible leak detection circuits constructed from the TT-FLAT PROBE and nVent RAYCHEM TraceTek leak detection cable being monitored by a nVent RAYCHEM TraceTek TTDM-128 and TT-SIM modules.

POTENTIAL CONFIGURATION EXAMPLE

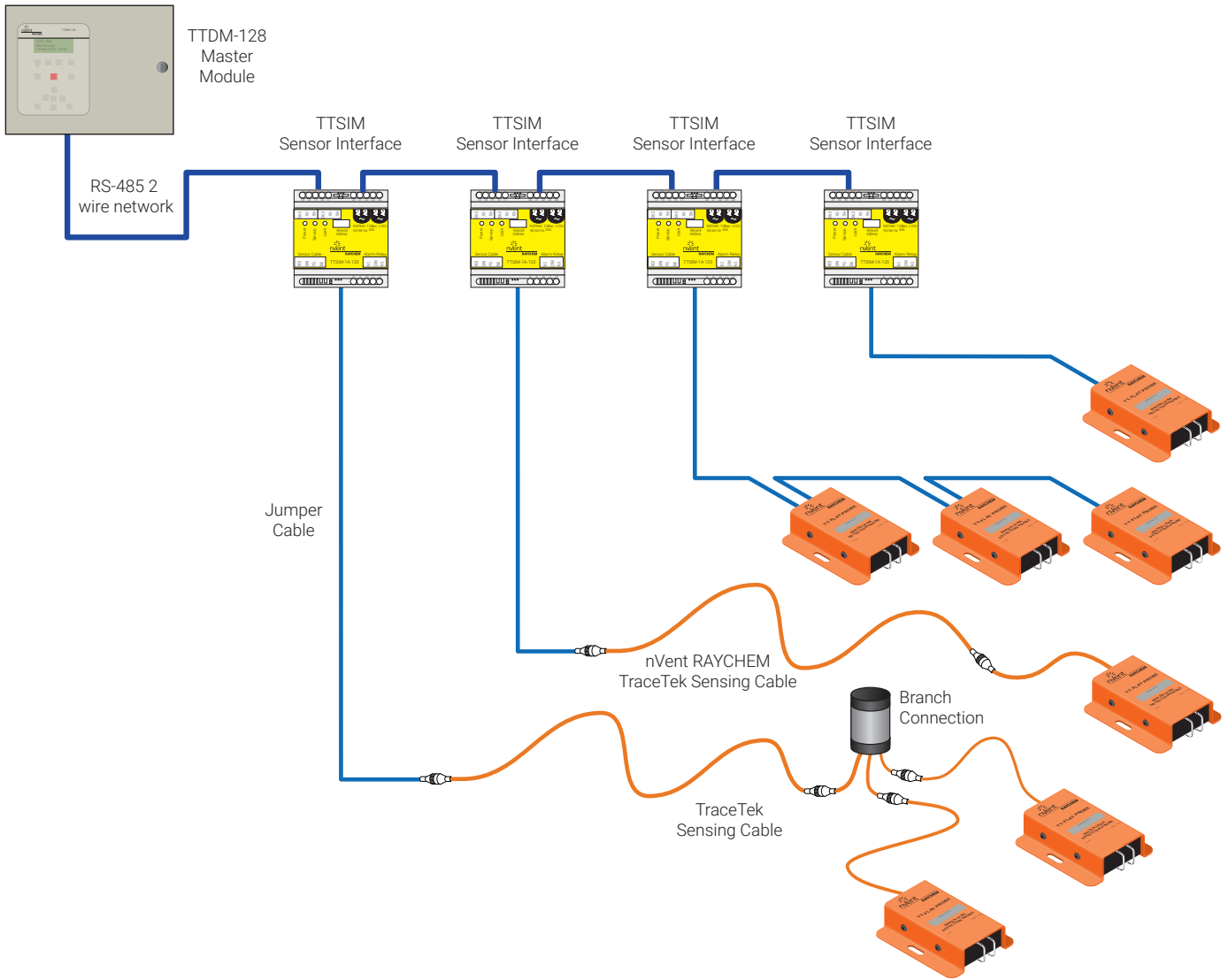

ORDERING INFORMATION

Catalog number	P/N	Description
TT-FLAT PROBE	P000001074	Water leak detection probe

PRODUCT CHARACTERISTICS

Dimensions nominal	4.7 in L x 3.8 in W x 1.3 in H (120 mm L x 98 mm W x 32 mm H)
Weight	0.4 lb nominal
Shroud	Epoxy coated aluminum, orange
Probes	363 Stainless steel
Probe height above mounting surface	Fixed @ 0.04–0.08 in (1–2 mm) when placed flat. Can be wall mounted to any depth required.
Housing	Black ABS plastic, UL 94 HB flammability rating
Maximum ambient temperature	122°F (50°C)
Minimum ambient temperature	32°F (0°C)
Connections	4-wire TraceTek jumper cable to terminal strip

APPROVALS AND CERTIFICATIONS

TT-FLAT PROBE is approved for installation in ordinary and hazardous areas when used in conjunction with approved nVent RAYCHEM TraceTek monitoring equipment and zener safety barriers when appropriate.

The TT-FLAT PROBE is designated as "simple apparatus" and included in the approval certification for nVent RAYCHEM TraceTek monitoring instruments.

Consult the specific data sheets and approval certificates for the nVent RAYCHEM TraceTek TT-TS12, TTDM-128, TTSIM-1, TTSIM-1A, TTSIM-2, TTC-1 and TT-FLASHER-BE for application limitations and specific area approvals and certifications.



The TT-FLAT-PROBE is FM approved for use in the TraceTek Water Leak Detection System when installed with an FM Approved TraceTek Alarm and Locator Module to detect and locate water.

North America

Tel +1.800.545.6258
Fax +1.800.527.5703
thermal.info@nVent.com

Europe, Middle East, Africa

Tel +32.16.213.511
Fax +32.16.213.604
thermal.info@nVent.com

Asia Pacific

Tel +86.21.2412.1688
Fax +86.21.5426.3167
cn.thermal.info@nVent.com

Latin America

Tel +1.713.868.4800
Fax +1.713.868.2333
thermal.info@nVent.com



Our powerful portfolio of brands:

CADDY ERICO HOFFMAN RAYCHEM SCHROFF TRACER