

## Gland Plate



1. Make cut-out in box as shown. Cutout may be positioned on any side of box.
2. To install gland plate, slip supports under back side of cutout, push gland plate down over cutout, and slide bracket under front edge of cutout. Finally, tighten wing nuts.
3. Dimensions in brackets [ ] are metric equivalent of decimal dimensions. One inch equals 25.4 mm.

This accessory maintains UL/CSA Type 12 when installed per these instructions.

This accessory is covered by UL file E61997 and CSA file LR42186.

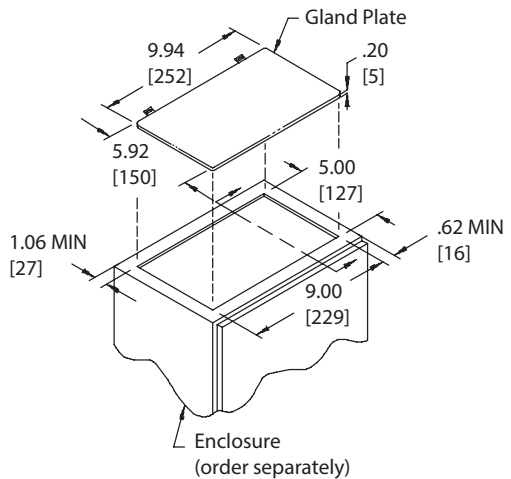
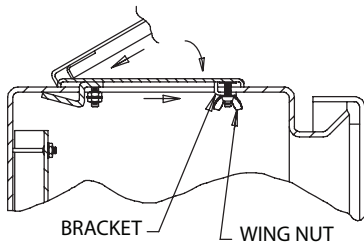

### **WARNING**

To avoid electric shock, do not energize any circuits before all internal and external electrical and mechanical clearances are checked to assure that all assembled equipment functions safely and properly.