

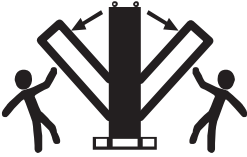

Enclosure Stabilizer
Einschließung Ausgleicher
Stabilisateur De Clôture
Estabilizador Del Recinto

nVent
HOFFMAN

⚠ WARNING



Enclosure is TOP-HEAVY

- Enclosure stabilizers alone are not to be used for permanent installation.
- Enclosure stabilizers are for temporary use only.
- Enclosure must be secured at the top in conjunction with the use of enclosure stabilizers.
- Follow guidelines in "Large Enclosure Handling Manual".

• To get additional copies of the "Large Enclosure Handling Manual", call 1-800-355-3560.

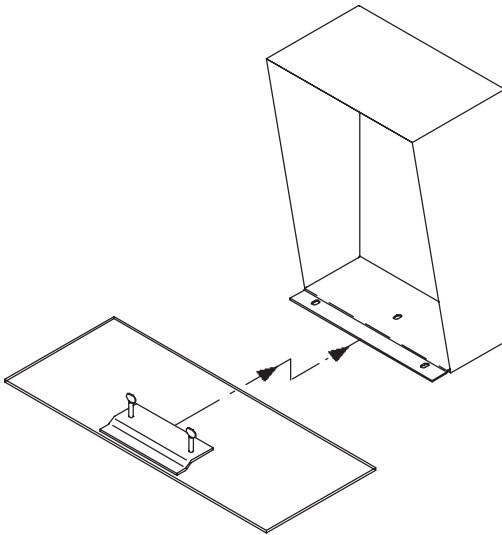

Step 1: Assemble stabilizer to mounting foot.

Schritt 1: Bauen Sie Ausgleicher zum Montagefuß zusammen.

Étape 1: Assemblez le stabilisateur au pied de support.

Paso 1: Monte el estabilizador al pie del montaje.

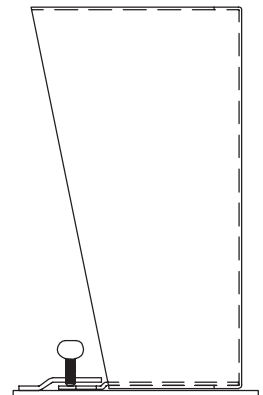

Step 2: Tighten stabilizer screws to mounting foot.

Schritt 2: Ziehen Sie Ausgleicherschrauben zum Montagefuß fest.

Étape 2: Serrez les vis de stabilisateur au pied de support.

Paso 2: Apriete los tornillos del estabilizador al pie del montaje.