

**PROLINE®**  
 Grounding Bar  
 Erdung Des Stabes  
 Fondre La Barre  
 Poner a tierra La Barra

**⚠ WARNING ⚠ WARNUNG ⚠ AVERTISSEMENT ⚠ PRECAUCION**





To avoid electric shock and equipment damage, disconnect power to enclosure before starting installation. Before installing ground system, read these instructions carefully. Failure to follow instructions could damage the product or cause a hazardous condition.

Um elektrischen Schlag und Ausrüstung Beschädigung, zu vermeiden trennen Sie Energie zur Einschließung bevor Sie Installation beginnen. Bevor Sie Grundsystem anbringen, lesen Sie diese Anweisungen sorgfältig. Störung, Anweisungen zu befolgen konnte das Produkt beschädigen oder einen gefährlichen Zustand verursachen.

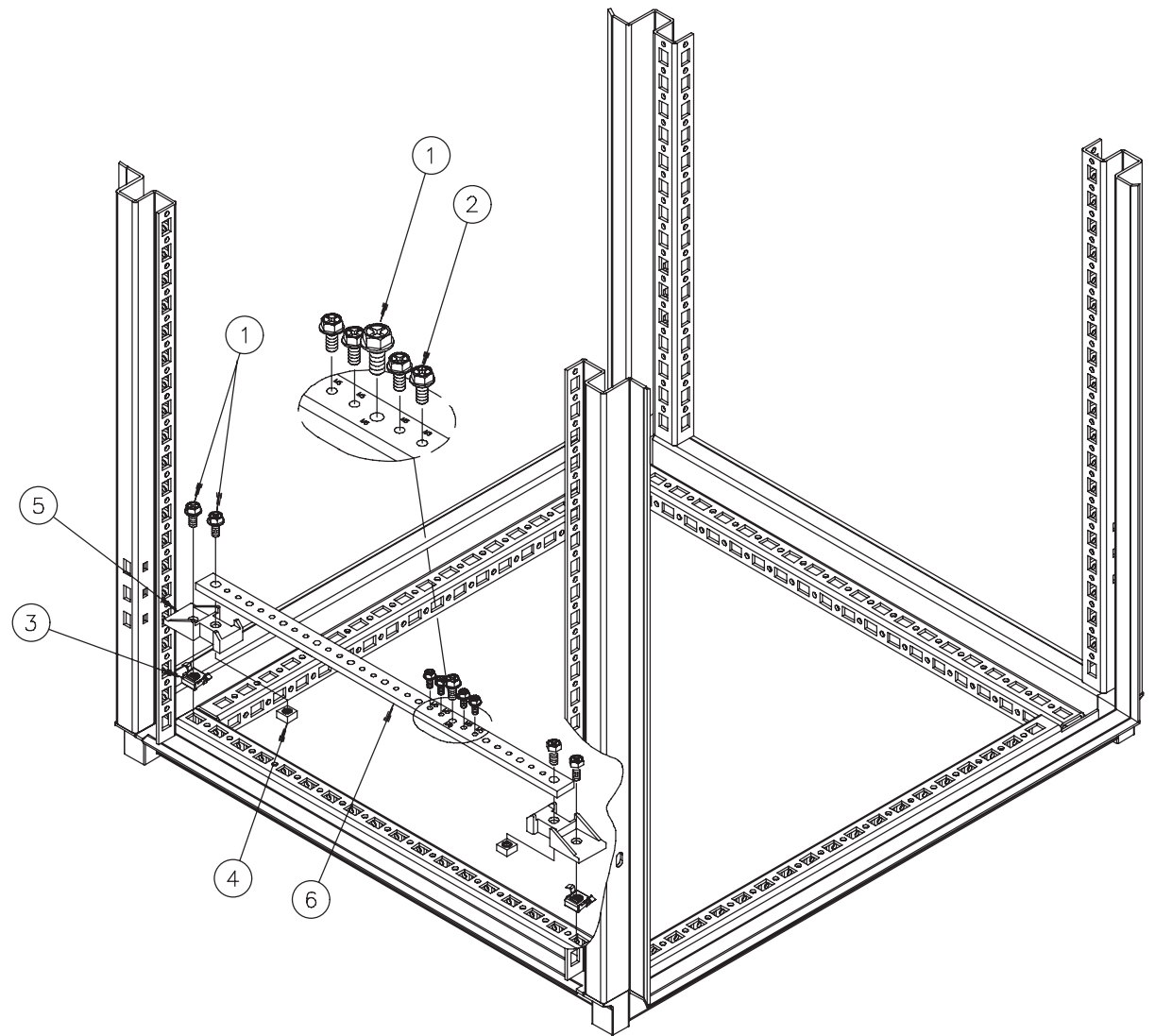
Pour éviter la décharge électrique et les dommages aux équipements, débranchez la puissance à la clôture avant de commencer l'installation. Avant d'installer le système au sol, lisez ces instructions soigneusement. Le manque de suivre des instructions a pu endommager le produit ou causer un état dangereux.

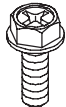
Para evitar descarga eléctrica y daño de equipo, desconecte la energía al recinto antes de comenzar la instalación. Antes de instalar el sistema de tierra, lea estas instrucciones cuidadosamente. La falta de seguir instrucciones podía dañar el producto o causar una condición peligrosa.

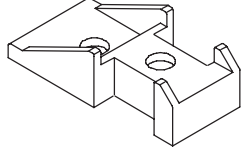
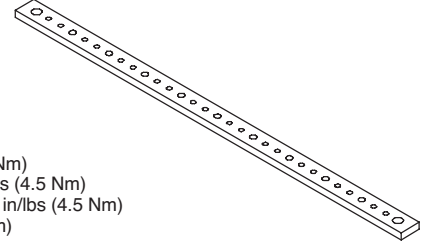

<p>1</p>  <p style="text-align: right;">(5x) (11x) (17x)</p>	<p>2</p>  <p style="text-align: right;">(10x) (20x) (31x)</p>	<p>3</p>  <p style="text-align: right;">(2x)</p>	
<p>4</p>  <p style="text-align: right;">(2x)</p>	<p>5</p>  <p style="text-align: right;">(2x)</p>		
<p>6</p>  <p style="text-align: right;">(1x)</p> <p style="font-size: small;">           Maximum Torque: 40 in/lbs (4.5 Nm)            Maximales Drehmoment: 40 in/lbs (4.5 Nm)            Couple de serrage maximum: 40 in/lbs (4.5 Nm)            Torque máximo: 40 in/lbs (4.5 Nm)         </p>			

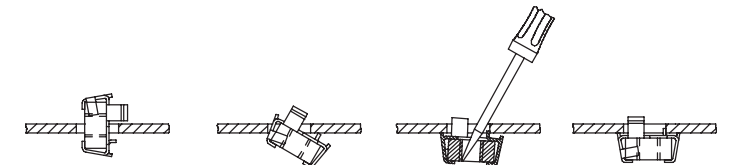
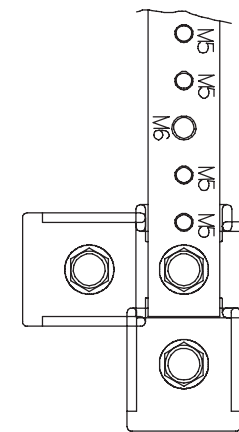

**Optional Mounting of End Brackets**  
**Wahlweise freigestellte Montage der Ende Haltewinkel**  
**Support facultatif des parenthèses d'extrémité**  
**Montaje opcional de los soportes del extremo**