





Top-Mount Filter Fans and Grilles

HR16 Models

INSTRUCTION MANUAL

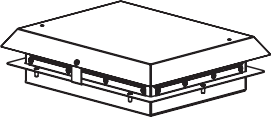
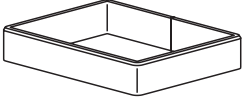
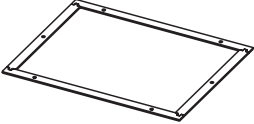
TABLE OF CONTENTS

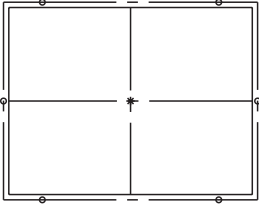
Installation Instructions.....	3
Assembly	4
Clearances	5
Wire Diagram	5
How to Read Model Numbers.....	6
Grille Filter Cleaning / Replacement	6
Replacement Parts	7
Warranty	7

<p>1</p> <p>HR16</p>  <p>(1x)</p>	<p>2</p>  <p>(1x)</p>
<p>3</p>  <p>(1x)</p>	<p>4</p> <p>M6x1</p>  <p>35 in/lbs (4 Nm)</p> <p>(6x)</p>
<p>5</p>  <p>(1x)</p>	<p>6</p> <p>HG13</p>  <p>Purchase Separately</p> <p>1x 2x</p>



CAUTION

Before cutting holes in the enclosure, verify all internal components are clear of the cutting tool to avoid damaging installed components.

INSTALLATION INSTRUCTIONS

1. Apply cutout template item 5 to the top of the enclosure located as desired. See Figure 1.
2. Cutout hole in enclosure.
3. Deburr the cutting edge.
4. Remove cowl top from top-mount filter fan, item 1.
5. Apply gasket, item 3 to enclosure.
6. Insert top-mount filter fan over gasket and into cutout hole and fasten with M6 hex nuts, item 4. Torque to 35 in/lbs (4 Nm).
7. Install filter item 2 around filter fan.
8. Re-install the filter fan cowl top.
9. Install one or two grilles using the grille cutout templates supplied with the grilles. Use the appropriate cutout size for the model grille purchased. Grilles are sold separately.
10. Verify the location of the enclosure with installed top-mount filter fan and grilles has a minimum clearance of 7.00 (178 mm). See Figure 3 on page 5
11. Wire the filter fan following the Wire Diagram as shown in Figure 4 on page 5.

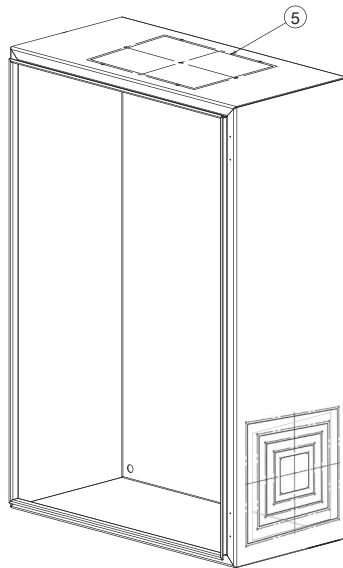

Figure 1

ASSEMBLY

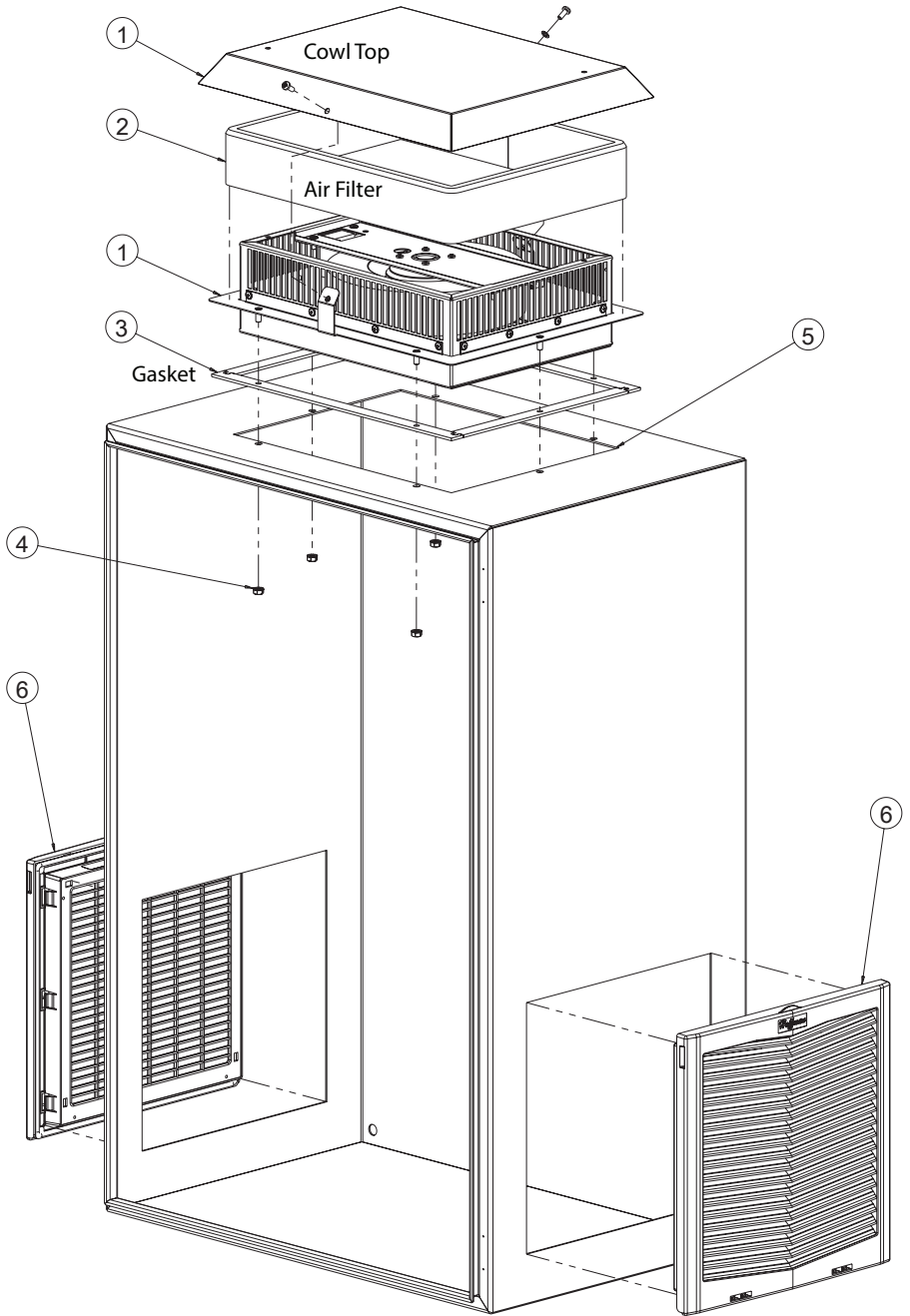

Figure 2

CLEARANCES

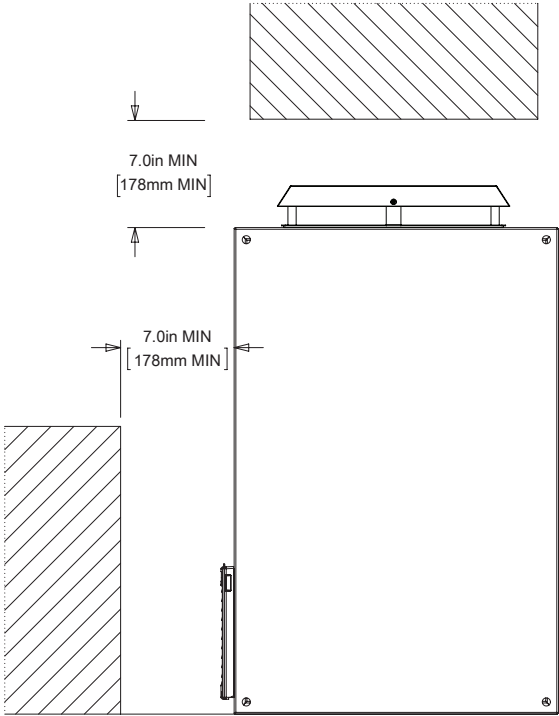

Figure 3

WIRE DIAGRAM

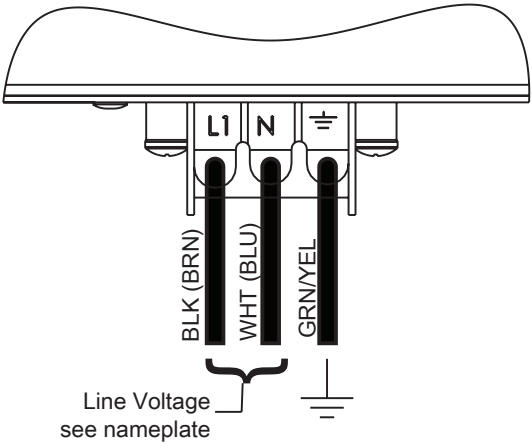

Figure 4

HOW TO READ MODEL NUMBERS

HR	16	16	4	1	4
1	2	3	4	5	6

1. Top-Mount Filter fan
2. Size
3. Voltage: 16 = AC 115/50/60/1
26 = AC 230/50/60/1
4. Rating: 4 = Type 12
5. Version 1 = 266 CFM
2 = 348 CFM
6. Color: 4 = RAL = RAL7035 Light Gray

GRILLE FILTER CLEANING / REPLACEMENT

Replacement Grille Filter Part Numbers	
Grille Models	Type 12 (\approx .50 [14 mm] thick)
HG10	89134426R
HG13	89134427R*

***Note:** HG grille replacement filters are only approved Type 12.

1. Open louvered grille.
2. Wash filter in warm water. Use mild detergent if necessary.
3. For greasy matter, wash in warm water containing a grease solvent.
4. Do not wring the filter.

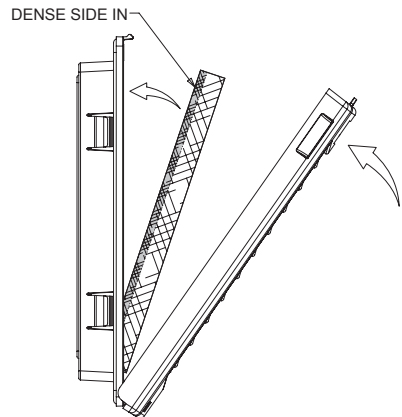
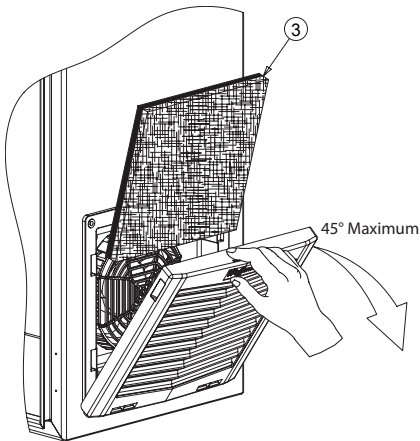

REPLACEMENT PARTS

Description	Part Number
Cowl Top	89133096SP
Air Filter	89139592R
Gasket	89140831SP

WARRANTY

Please register your product and reference the Hoffman Cooling Product Warranty located here:

<https://hoffman.nvent.com/en/hoffman/warranty-information>



nVent
2100 Hoffman Way
Anoka, MN 55303 USA
☎ +1.763.422.2211
📠 +1.763.576.3200

nVent.com