

Sequestr

High Amp External Disconnect Enclosure
For Cable Operated Devices



Table of Contents

Sequestr Hardware.....	3
Preparing for Installation of Sequestr High Amp Cable Operated Devices	4
Powering Down the System.....	4
Removing Old Hardware	4
Preparing the Control Enclosure.....	4
Sequestr Enclosure Mounting Instructions	5
Installing the Circuit Breaker/Disconnect Switch and Associated Hardware.....	6
Cable Operated Device Operating Handle Installation	6
Interlock Installation.....	7
Labeling.....	8
Powering Up the System.....	8
Accessing the Enclosure.....	8
Opening the Control Enclosure Door with Power “ON”	8
Opening the Sequestr Enclosure Door with Power “OFF”	8
Sequestr Enclosure Grounding	9
Sequestr Panel Installation / Grounding	9
Hardware Kits	10
Repainting Instructions	10
Drill Patterns for 54-Inch Tall Sequestr Models.....	11
Cutout Template Dimensions for 54-Inch Tall Sequestr Models.....	15

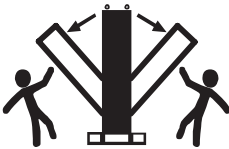

Note: These instructions are for assembling the following Sequestr external disconnect enclosure accessory to an existing disconnect enclosure.

 WARNING	
<p>The functions, fits, and clearances of the installation described herein are calculated from information supplied by the manufacturers of the equipment to be installed. Be certain to check the function, fits, and clearances of all equipment both before and after installation to assure that it operates properly and safely and meets all applicable codes, standards, and regulations.</p> <p>In the event the completed installation does not function properly or fails to meet any such codes, standards, or regulations, do not attempt to make alterations or operate the equipment. Report such facts immediately to:</p> <p style="text-align: center;">nVent HOFFMAN Customer Service 2100 Hoffman Way Anoka, MN 55303 763 422 2211 http://hoffman.nvent.com/contact-us</p>	
<p>To avoid personal injury and/or product damage, DO NOT attempt the installation alone. The installation of the Sequestr enclosure to the control enclosure requires two people.</p>	
	<p>Control Enclosure is TOP-HEAVY</p> <ul style="list-style-type: none"> Stabilize the control enclosure before mounting the Sequestr external disconnect enclosure to it. Follow guidelines in “Large Enclosure Handling Manual” supplied with the control enclosure. <p>To get additional copies of the “Large Enclosure Handling Manual”, call 1-800-355-3560.</p>

Notice:

To maintain the environmental rating of this enclosure, install in any opening, only listed or recognized disconnect devices, hole seals, and/or conduit hubs that have the same environmental rating as the enclosure. Install in compliance with the installation instructions of the device.

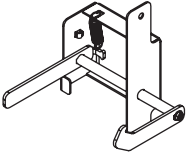
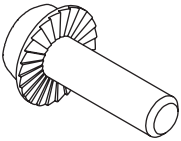
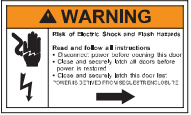
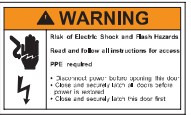
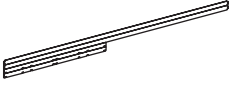
Sequestr Hardware

<p>1</p>  <p>(1x)</p>	<p>2</p> <p>M6X20</p>  <p>TORQUE: 50 LBF/IN</p> <p>(15x)</p>
<p>3</p>  <p>(2x)</p>	<p>4</p>  <p>(2x)</p>
<p>5</p>  <p>(1x)</p>	<p>6</p>  <p>(1x)</p>

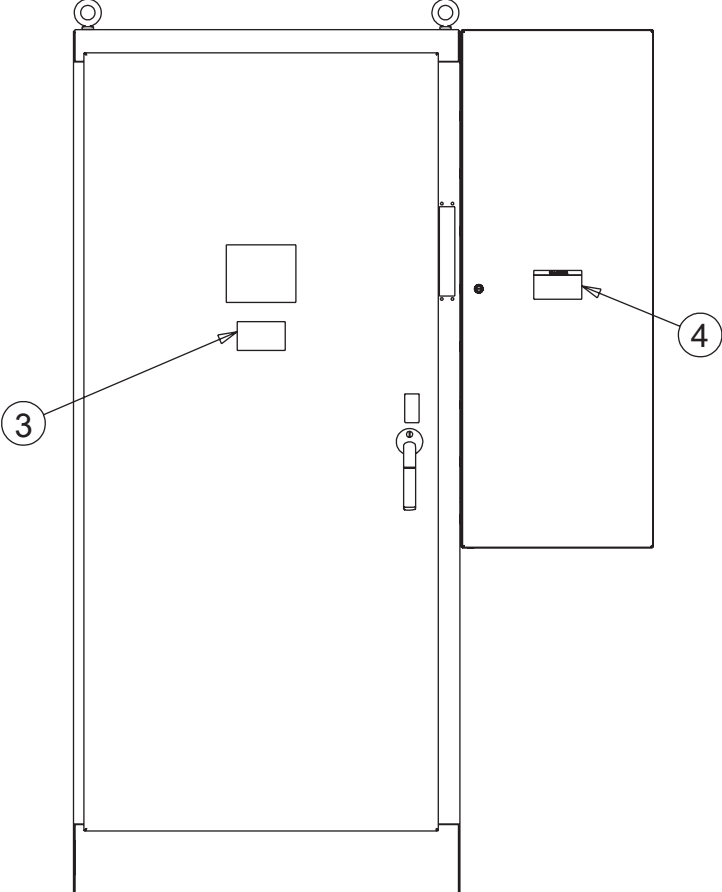

Preparing for Installation of Sequestr High Amp Cable Operated Devices

NOTE: The instructions on this page are for preparing to mount a Sequestr enclosure to an existing disconnect control enclosure.

Powering Down the System

1. Turn off the local disconnect installed in the control enclosure using the appropriate right or left hand rule.
2. Turn off all power to the enclosure. It could possibly be the disconnect on the bus bar.
3. Put on the correct level of Personal Protective Equipment (PPE).
4. Open the control enclosure.
5. Test for power on the incoming side of the disconnect using a volt meter.

Removing Old Hardware

1. Remove the existing disconnect/breaker from the control enclosure.
2. Remove the incoming power feed and seal the existing hole using a Hoffman hole seal (order separately).
3. Cover and protect all components installed in the control enclosure.

Preparing the Control Enclosure

1. Referring to the Drill Patterns for 54-Inch Tall Sequestr Models section on pages 11-14 of these instructions, mark the Sequestr mounting hole locations on the control enclosure from the appropriate layout pattern for the enclosure bulletin and size.

* 1:1 scale downloadable templates are available at nVent/Hoffman.com.

If using the downloadable template, or making one from the dimensions given, it is suggested that the holes be resized to allow drill bushings to be installed.

2. Drill, cut and deburr the holes in the side of the control enclosure.

Sequestr Enclosure Mounting Instructions

1. Remove the subpanel from the Sequestr enclosure for installation of the disconnect switch or circuit breaker. **Save the hex nuts for reinstallation.**
2. Locate, drill and deburr a hole for the power line entrance into the Sequestr enclosure.
3. Install the gasket per Figure 1A, engaging the dove tail joints, and trim off any excess, Refer to Figure 1B for the correct enclosure depth configuration.
4. Referring to Figure 1C, raise and support the Sequestr enclosure to the side of the control enclosure. Alignment can be aided by inserting alignment guide pins through one or two holes from the inside of the control enclosure.
5. Install thirteen (13) M6x20mm washer head cap screws (Item 2) from inside the control enclosure at the locations shown and tighten.
6. Ground washer (Item 6) may be installed on any of the mounting screws.

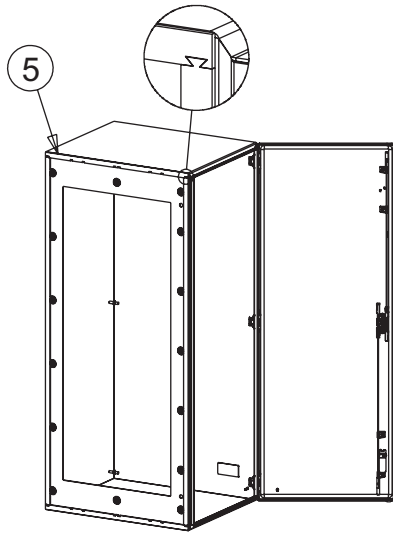

Figure 1A

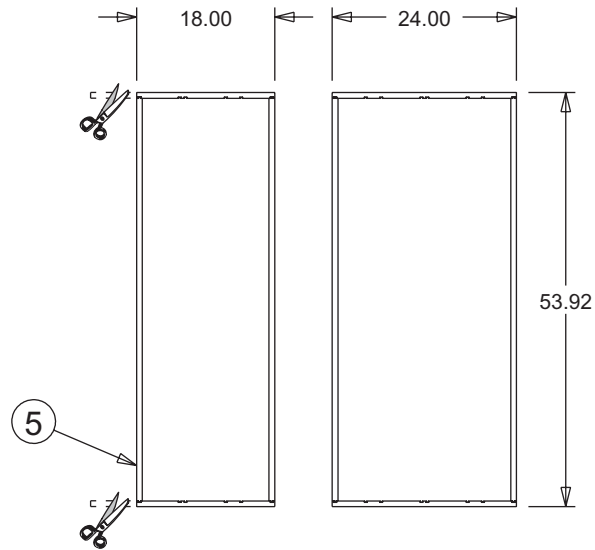

Figure 1B

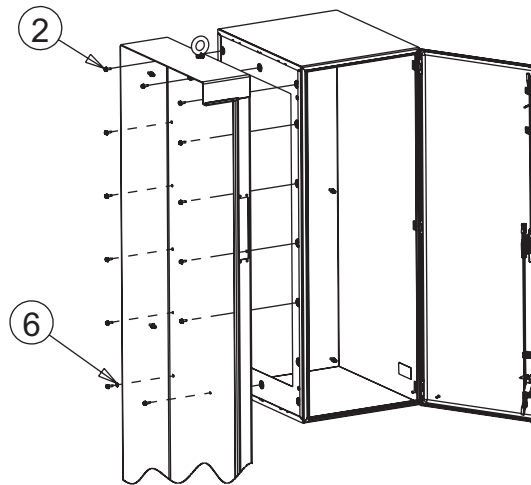

Figure 1C

Installing the Circuit Breaker/Disconnect Switch and Associated Hardware

1. Drill mounting holes in the panel for the specific cable operated disconnect switch/circuit breaker being installed. Additional holes may be required when using fused switches. See the device manufacturer's instructions.
2. Install the cable operated circuit breaker mechanism or disconnect switch, trailer fuse block, and fuses onto the panel per the device manufacturer's instructions.
3. Install the populated panel into the Sequestr enclosure. Secure with the six previously saved hex nuts.
4. Punch, drill or cut holes in the side of the control enclosure to allow wires to pass through using approved gland(s). Add wiring from the load side of the trailer fuse block/circuit breaker to the existing wiring or the incoming power side of components in the control enclosure. Seal around the wires to maintain a Type 1 rating. Terminal blocks (ordered separately) are also available to aid in the effort.
5. Install conduit and wires to the line side of the circuit breaker/disconnect switch in the Sequestr enclosure.

Cable Operated Device Operating Handle Installation

1. Install the operating handle and associated hardware (adapter kit, door hook, etc.) in the control enclosure per the device manufacturer's instructions.
2. Based on the length of the operating cable, determine if the loop in the cable will be in the control enclosure or in the Sequestr enclosure. Mark, cut, and deburr a hole in the wall of the control enclosure for the cable to pass through that maintains the manufacturer's recommended bend radius without kinking or binding. A slot that will allow the cable to freely pass through at a reduced angle to the wall may be preferred. (See figure 2.) Note: If the cable cannot be disconnected from the switch or breaker operating mechanism it may be necessary to make a cutout large enough for the device operating mechanism to pass through.
3. Pass the cable through the enclosure side wall and connect to the switch/breaker per manufacturer's instructions. If a larger hole/cutout was required, the installer may need to make and install a cover plate that has a slot for cable passage and maintains a Type 1 rating.

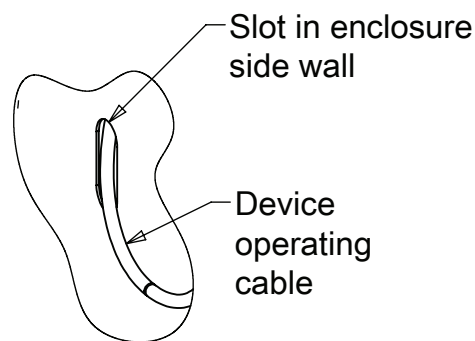

Figure 2

Interlock Installation

1. Referring to Figure 3, with the interlock arm removed, install the control enclosure interlock (Item 1) with the shaft passing through the hole in the control enclosure and into the Sequestr enclosure. Secure the interlock with the two remaining M6x20mm washer head cap screws (Item 2)
2. Install the interlock arm onto the shaft so it protrudes out of the Sequestr enclosure door opening. It should be installed with the hook facing up and parallel with the arm on the opposite end of the shaft. Secure the arm with the screw provided. Apply Loctite 262 as indicated.

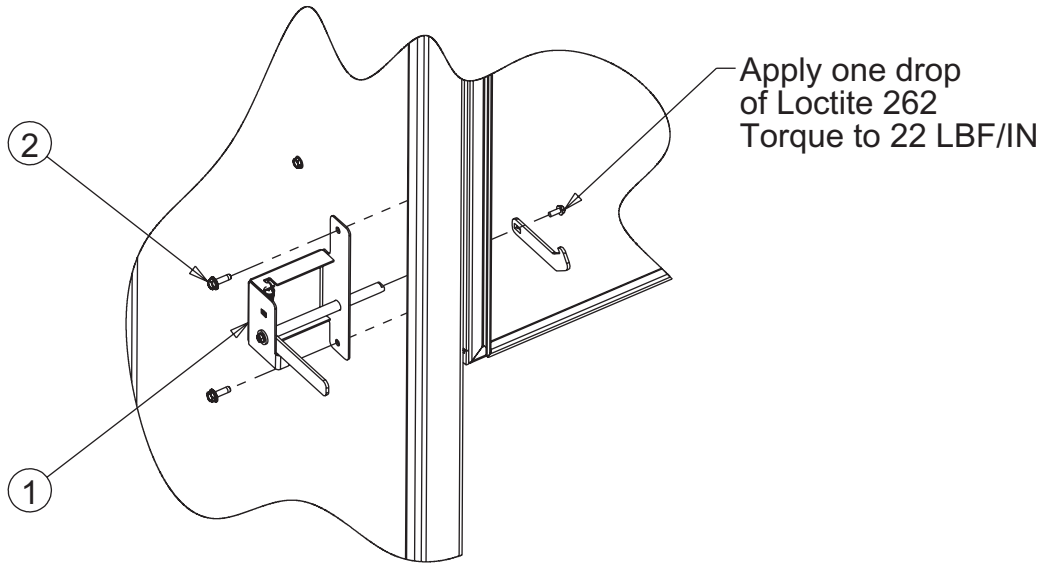

Figure 3

Labeling

Add the derived power label (Item 3) to the control enclosure below the tipping warning label as shown on page 3 of this instruction. The arrow on the label should be pointing toward the Sequestr enclosure.

NOTE: Extra warning labels (Items 3 and 4) are included for the purpose of and should be applied after the enclosure is painted or the original label is destroyed. Customers should contact nVent for any additional warning labels in the event they cannot find the extra labels or need more.

Powering Up the System

1. Remove any component protective covering that may have been installed per step 3 of “Removing Old Hardware and Preparing the Control Enclosure” on page 4.
2. Verify the operator handle is in the “OFF” position.
3. Close the Sequestr enclosure door and latch securely. The control enclosure door stop arm should rotate upward.
4. Close the control enclosure door and latch securely. The control enclosure door will now hold the interlock in the position and prevent the Sequestr door from being opened.
5. Restore power to the enclosure (possibly the disconnect on the bus bar).
6. Flip the operator handle on the Sequestr enclosure to the “ON” position using the appropriate right or left hand rule.
7. Verify that the machine / system operates with the new electrical connection.

Accessing the Enclosure

Opening the Control Enclosure Door with Power “ON”



1. Defeat the operator handle per the device manufacturer’s instructions.
2. Open the control enclosure door
3. Sequestr door can be opened after control enclosure door is opened.

Opening the Sequestr Enclosure Door with Power “OFF”

1. Open the master door on the control enclosure. The interlock stop arm will be free to rotate down and release the Sequestr door latch.
2. Open the Sequestr enclosure door.

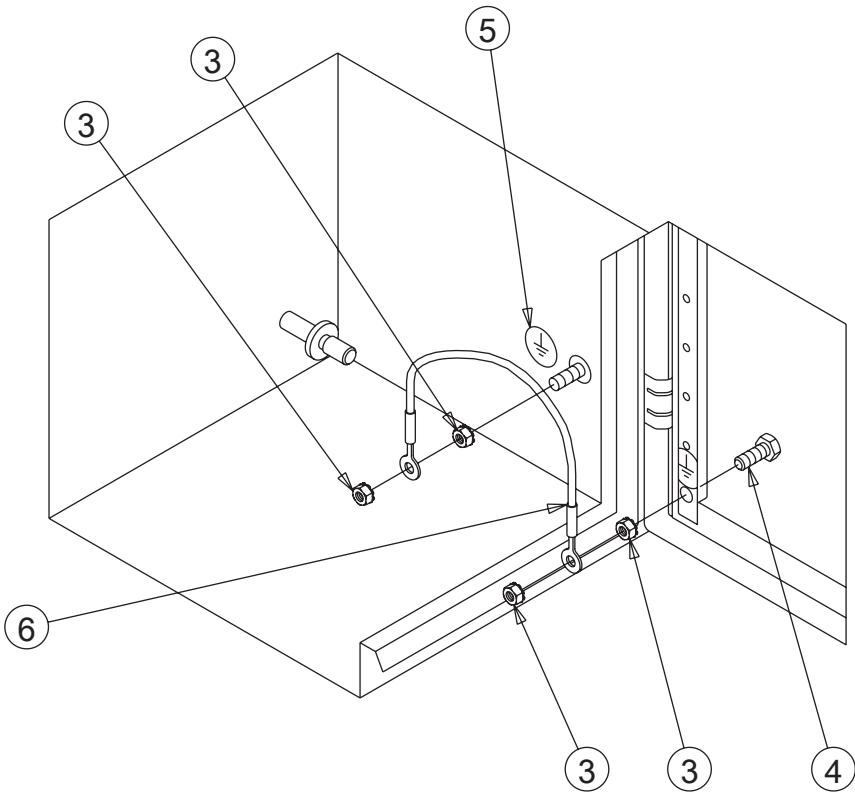
Sequestr Enclosure Grounding

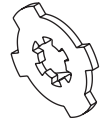
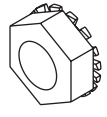
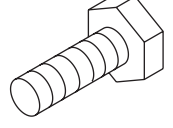

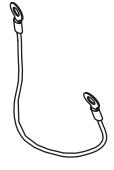
<p>1</p>  <p>(Panel mounting nut in enclosure)</p>	<p>2</p>  <p>(1x)</p>
<p>3</p>  <p>(6x)</p>	<p>4</p>  <p>(2x)</p>
<p>5</p>  <p>(2X)</p>	<p>6</p>  <p>Supplied by customer (0X)</p>

Sequestr Panel Installation / Grounding

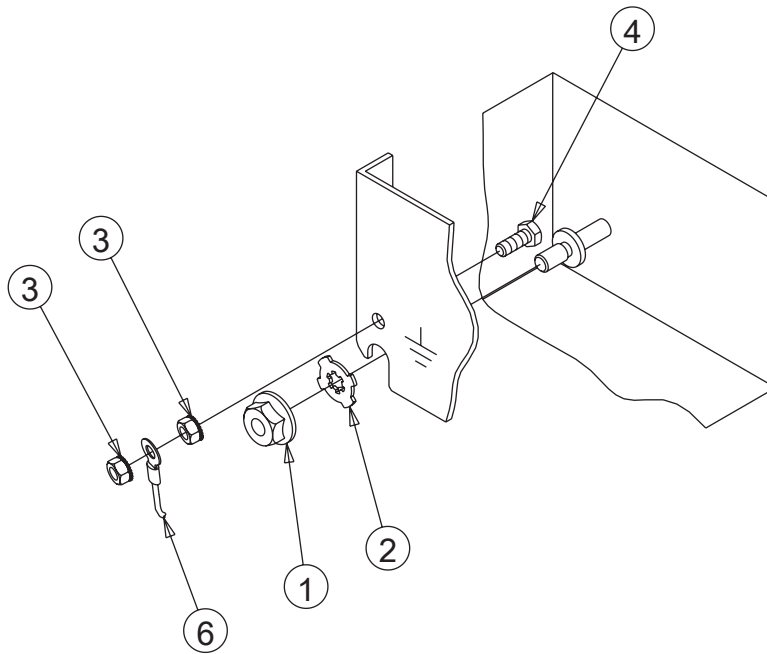

Hardware Kits

Shown are the proper installation procedures for grounding the doors, covers, and optional panels and mounting the optional side and back panels.

Ground wires (Item 6) are available from nVent HOFFMAN at nvent.com/hoffman.

Repainting Instructions

Suggested Paints: The following paints typically provide superior adhesion qualities:

- Two Component Epoxies
- Two Component Polyurethanes
- Lacquers
- Acrylics
- Alkyd Baking Enamels
- Industrial Enamel

Surface Preparation: Wet wipe all surfaces to be painted with xylene solvent. Allow surfaces to flash dry three to five minutes. If a delay of greater than two hours occurs before painting, wet wipe again.

Painting: Apply top coat per paint manufacturer's instructions. Allow adequate cure time between coats.

Allow top coat to cure completely prior to testing paint adhesion. Consult with the paint manufacturer for proper cure time.

Drill Patterns for 54-Inch Tall Sequestr Models

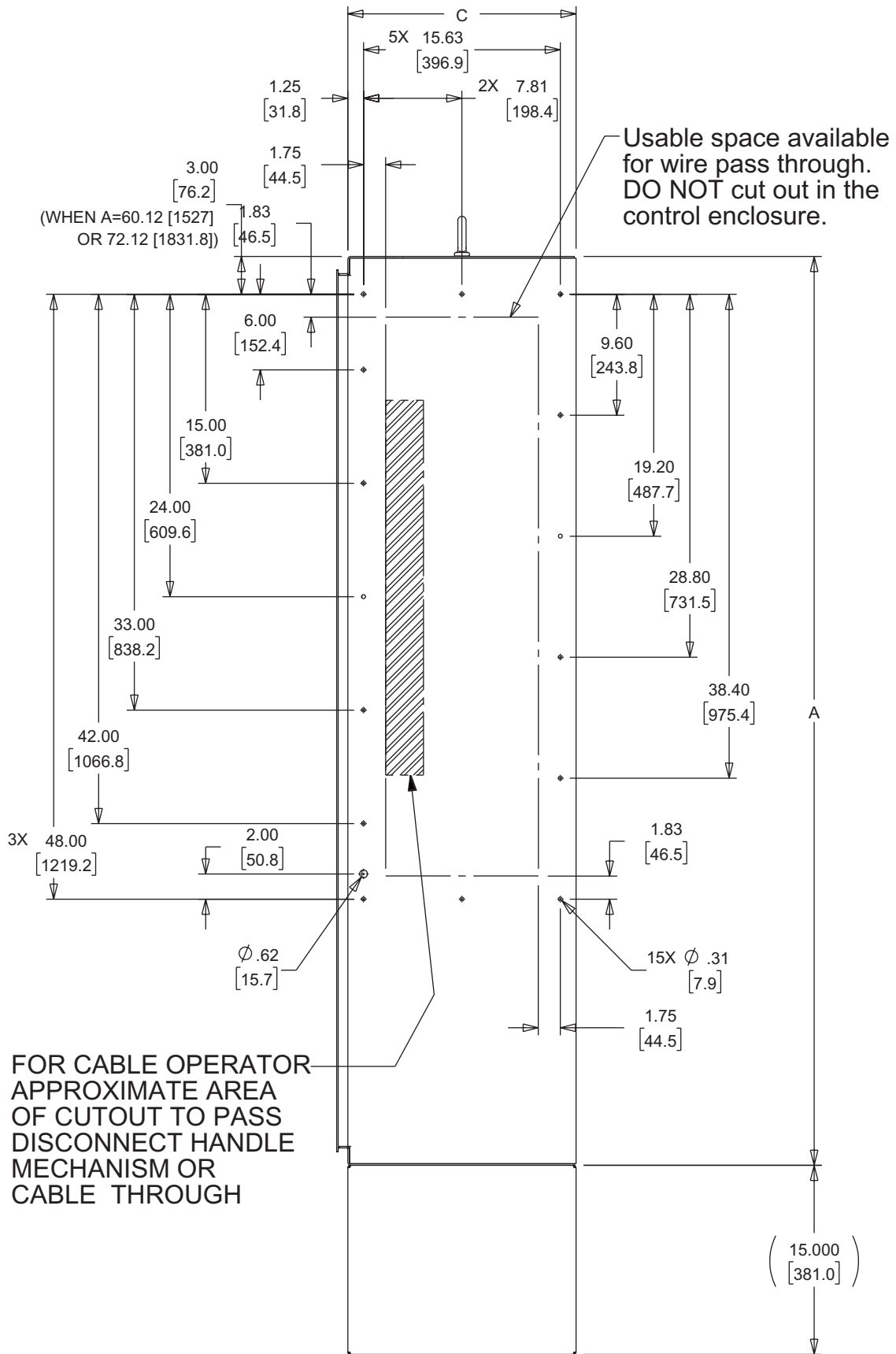

54 INCH SEQUESTR
 C = 18.12 [460.2]
 BUL- A21, A21S4

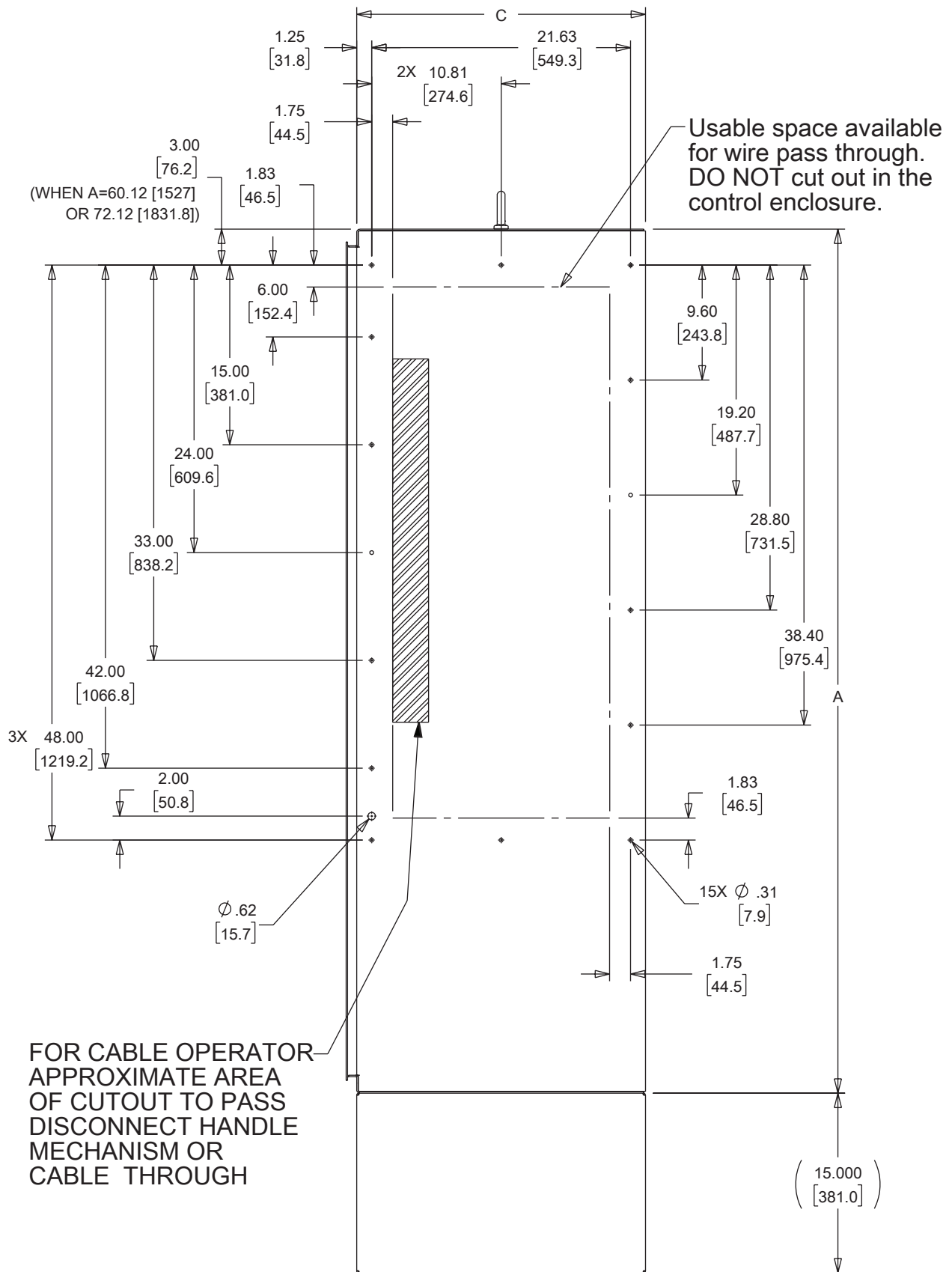

54 INCH SEQUESTER
 C = 24.12 [612.6]
 BUL- A21, A21S4

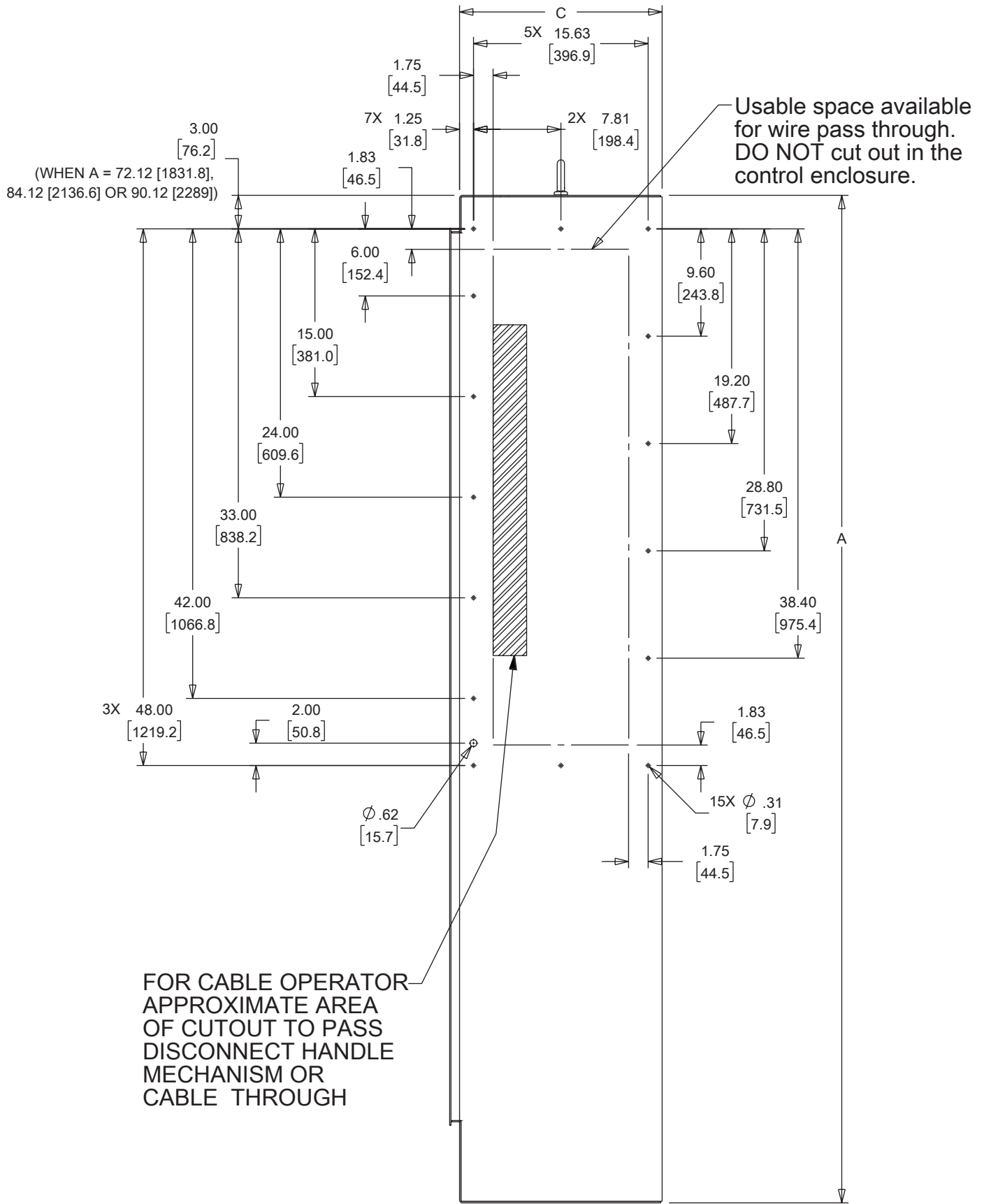

54 INCH SEQUESTER
 C = 18.12 [460.4]
 BUL - A28, A34, A4L3D, A28S4

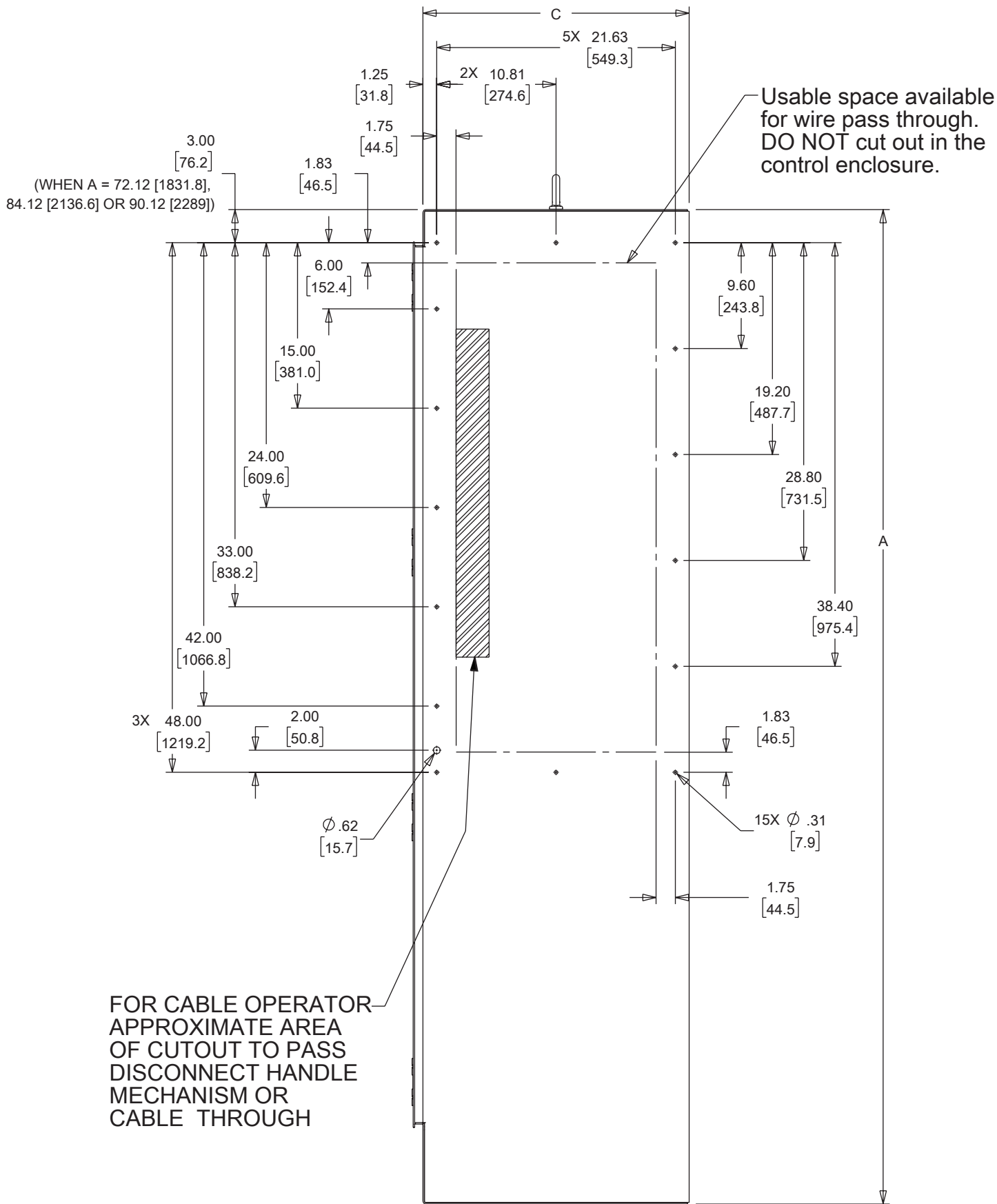

Cutout Template Dimensions for 54-Inch Tall Sequestr Models

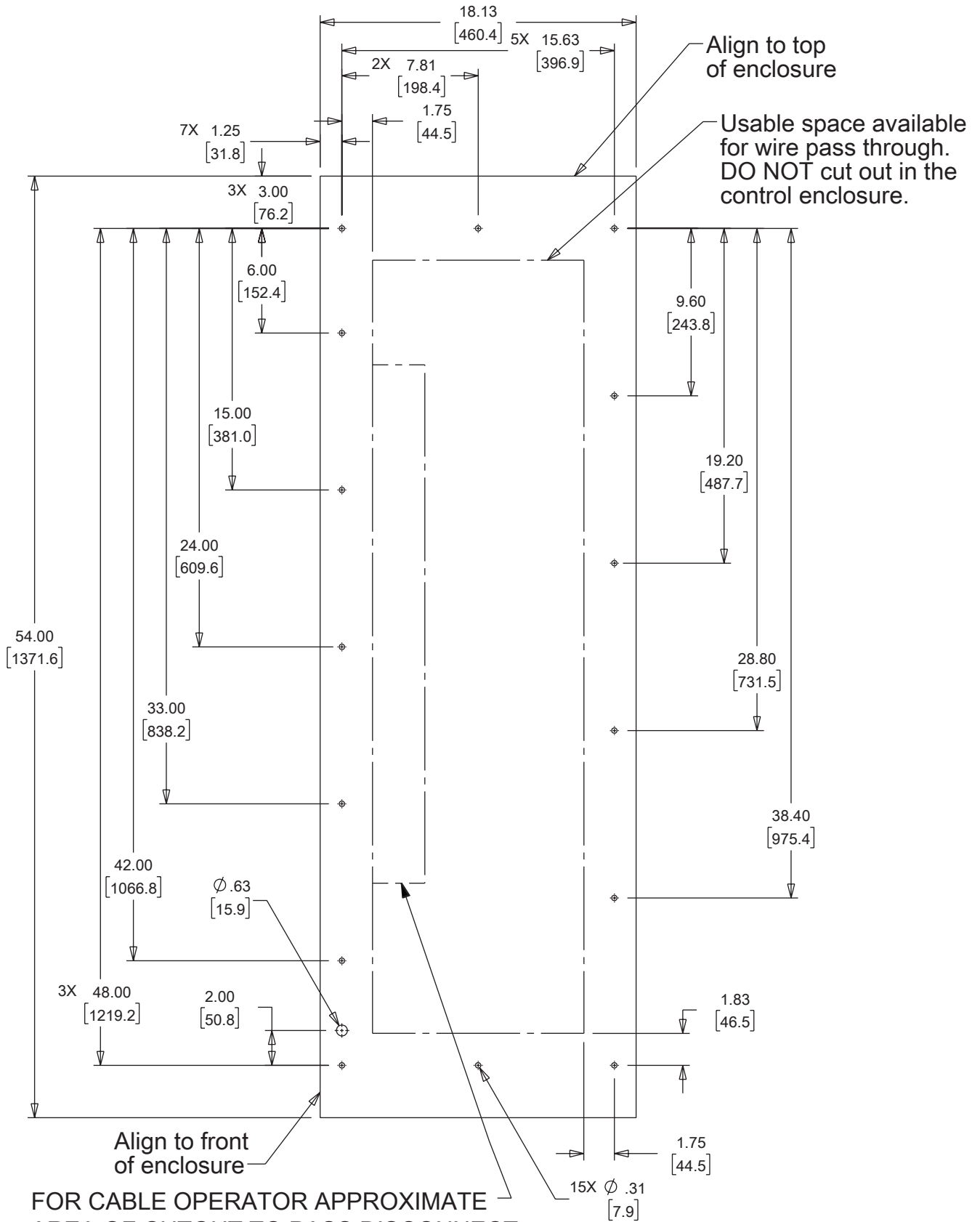

FOR CABLE OPERATOR APPROXIMATE AREA OF CUTOUT TO PASS DISCONNECT HANDLE MECHANISM OR CABLE THROUGH

TEMPLATE FOR 54 X 18 SEQUESTR
(1:1 scale downloadable template is available at nVent/hoffman.com)

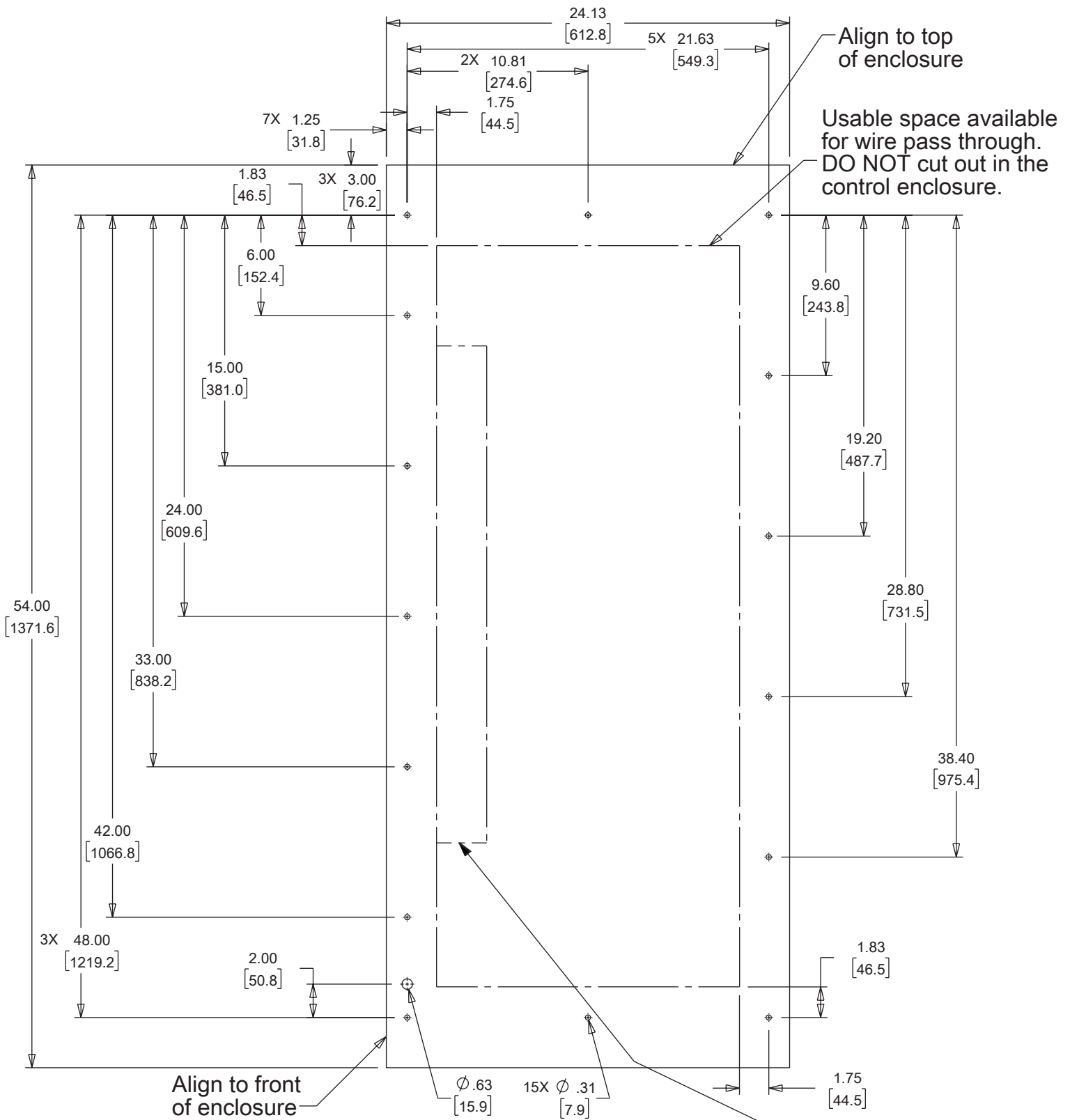

FOR CABLE OPERATOR APPROXIMATE AREA OF CUTOUT TO PASS DISCONNECT HANDLE MECHANISM OR CABLE THROUGH

TEMPLATE FOR
54 X 24 SEQUESTR
(1:1 scale downloadable template is available at nVent/hoffman.com)