

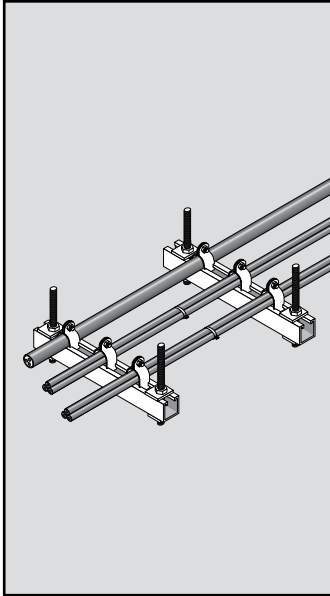

PYROTENAX

Commercial MI Wiring Cable

Installation Manual for System 1850,
System 1850-SE, System 1850Z and
System 1850 for Space Savings Wiring



Important Safeguards and Warnings

WARNING: FIRE AND SHOCK HAZARD.

nVent PYROTENAX mineral insulated (MI) power cables must be installed in accordance with these manufacturer's installation instructions and the requirements of national and local codes. In addition, fire-rated cables must be installed in accordance with all requirements of the UL Electrical Circuit Integrity System Listing. Read these important safeguards and carefully follow the installation instructions.

- Ensure the cable has been stored properly and is in good condition prior to commencing installation.
- Take all appropriate precautions when installing cables, including following OSHA and other applicable regulations.
- Store pull ropes in a clean, dry area, out of direct sunlight, and away from extreme heat.
- Store cables and accessories indoors in a clean, dry area.
- During the time that the cables are exposed and during cable pulling activities, protect cables from nearby or overhead work to prevent damage to the cable sheath.
- When installing fire-rated cables, use only steel or copper in the support system; no other materials are acceptable.
- Do not pull cables around corners that have sharp edges, such as corners in cable trays, or other obstructions.
- Prevent damage to cable by removing any abrasions or sharp edges from surface of support system.
- Support fire-rated cable in the manner described in the Electrical Circuit Integrity System Listing.

Table of Contents

1	General Information	1
	1.1 Use of the Manual	1
	1.2 Safety Guidelines	2
	1.3 Approvals	2
	1.4 Warranty	3
	1.5 General Assistance	4
	1.6 Markings	4

2	Introduction	5
	2.1 General	5
	2.2 Typical MI Cable Applications	6

3	Storage and Handling	11
	3.1 Storage	11
	3.2 Handling	13

4	Pre-Installation	17
	4.1 Minimum Installation Temperature	17
	4.2 Precautions	17
	4.3 Installation Equipment	18
	4.4 Set-up	19
	4.5 Cable Attachment Methods	21

5	Installation	22
	5.1 General Installation Guidelines	22
	5.2 Installing System 1850 and System 1850Z 2-Hour Fire-Rated Cable	33
	5.3 Installing System 1850 for Space Saving Non-Fire-Rated Cable	61
	5.4 Installing System 1850-SE Service Entrance Cable System	63
	5.5 Installation Photos	71

6	Testing	71
	6.1 Insulation Resistance (IR) Testing	71
	6.2 Improving Insulation Resistance	74
	6.3 Mineral Insulated Wiring Installation Record	77

7	Appendix	85
	Appendix A: Expansion and Vibration	85

1

General Information

1.1 Use of the Manual

This manual covers storage and installation of nVent PYROTENAX System 1850 and System 1850Z 2-hour fire-rated, and System 1850-SE service entrance mineral insulated (MI) cables. It is assumed that the cables have been properly sized and the installation properly designed. Installers must be properly trained and familiar with relevant codes and generally accepted good practice for handling and installing power cables. For installations or situations that are not covered in this guide, please contact uVent for guidance.

This manual gives general instructions that apply to all two systems listed above. Where applicable, instructions that apply only to a specific system, or to the USA or Canada, are clearly identified.

In addition to this manual, the supporting materials below are available on our website and on our YouTube channel. Click the links below to access the materials.

Title	Doc No.	Video No.
Quickterm Termination Procedure for Single Conductor MI Power Cables	H58290	H59063
PyroPak Termination Procedure for Multi-conductor MI Power Cables	H58872	H59064
PyroPak Termination Procedure for Twisted, Shielded Pair MI Communication Cable	H59074	H59065
Continuity Testing Procedure for MI Power & Communication Cables	H58872 , Appendix A	H59066
Megger Testing Procedure for MI Power & Communication Cables	Appendix 6.1	H59067
Field Installed Fire-Rated Splice Kit Assembly Procedure	H59479	N/A
Fire-Rated Three-Way Splice Assembly Procedure	H60149	N/A
Pyropak Termination Procedure for Fire-Rated Three-Way Splice MI Cables	H60235	N/A



1

General Information

1.2 Safety Guidelines

The safety and reliability of an MI cable system, and fire-rated systems in particular, depend on the proper design and installation of the system, and use of the proper materials for support, as well as the cable selected. Incorrect design or installation or use of inappropriate support materials can result in a system that may not perform properly, and in the case of a fire-rated system, it may not perform under fire conditions.

The guidelines and instructions contained in this booklet are important. Follow them carefully to ensure that the MI cable system will perform reliably. For fire-rated systems, pay special attention to installation details so that the system will perform reliably if subjected to a fire.

- Important instructions are marked  **Important**
- Warnings are marked  **WARNING**

1.3 Approvals

MI power cable and terminations are manufactured and approved to US and Canadian standards.

Approved Voltage Ratings for MI Cables, by application:

- Type MI: 600V Electrical rating - 600V Fire rated
- Type LWMI: 300V Electrical rating - 120V Fire rated

System 1850 MI cables are:

- UL Listed and CSA Certified
- 2-hour fire-rated per UL 2196 and ULC-S139 (1850°F with a water hose stream)
- A Classified Electrical Circuit Integrity System (FHIT), System No. 1850, in the UL Fire Resistance Directory
- A Listed Electrical Circuit Integrity System (FHIT7), System No. 1850, in the ULC Fire Resistance Directory

Factory Splices (FRJ) are:

- A Classified Electrical Circuit integrity System (FHIT), System No. 1850, in the UL Fire Resistance Directory when used with System No. 1850 cable (tested with hose stream)

1

General Information

- A Listed Electrical Circuit Integrity System (FHIT7), System No. 1850, in the ULC Fire Resistance Directory when used with System No. 1850 cable (tested with hose stream)

Field Installed Fire-Rated Splices (FIFRS):

- Splice is part of the Electrical Circuit Integrity System (FHIT) System No. 1850 in the UL Fire Resistance Directory when used with UL Classified System No. 1850 cable (tested with hose stream)
- Splice is part of the Electrical Circuit Integrity System (FHIT7) System No. 1850 in the ULC Fire Resistance Directory when used with ULC Listed System No. 1850 cable (tested with hose stream)

Fire-Rated Three-Way Splice (1-Hour Fire-Rated)

- Splice is part of the Electrical Circuit Integrity System (FHIT) System No. 1850 in the UL Fire Resistance Directory when used with UL Classified System No. 1850 Cable (tested with hose stream)
- Splice is part of the Electrical Circuit Integrity System Certified for Canada (FHIT7) System No. 1850 in the ULC Fire Resistance Directory when used with ULC Classified System No. 1850 Cable (tested with hose stream)



Important certification notice. At the time of publication, the following elements are not listed or certified for use in 2-hour fire-rated applications. Refer to UL Product iQ online directory for latest updates or contact nVent.

- **Galvanized / zinc coated cable tray**
- **System 1850 for space savings**

1.4 Warranty

nVent PYROTENAX commercial wiring products Limited Warranty applies to these products. For details, see the complete warranty on our web site at <https://pyrotenax.nvent.com/en-ca/warranty-information>



Important: For the nVent warranty and agency approvals to apply, the instructions that are included in this manual and product packages must be followed.

1

General Information

1.5 General Assistance

For information regarding other applications, design assistance or technical support, contact your nVent representative or nVent directly.

nVent

250 West St.

Trenton, ON, K8V 5S2

Canada

Tel: +1.800.545.6258

Fax: +1.800.527.5703

thermal.info@nvent.com

nVent.com

1.6 Typical Cable Markings

Bare:

Single Conductor:

[CABLE REFERENCE] NVENT-PYROTENAX SYSTEM 1850 TYPE MI 600V [# OF CONDUCTORS] [CONDUCTOR SIZE] C(UL)US FOR CT USE DIR BUR, SUN RES, GAS&OIL RES I, II-FRR 2H (FHIT/7.1850) S139 & 2196, MAX 600V CSA-C/US HL CLI GRP ABCD CLII GRP EFG CLIII



Multi Conductor:

[CABLE REFERENCE] NVENT-PYROTENAX SYSTEM 1850 TYPE MI 600V [# OF CONDUCTORS] [CONDUCTOR SIZE] C(UL)US FOR CT USE DIR BUR, SUN RES, GAS&OIL RES I, II-FRR 2H (FHIT/7.1850) & FRR 1H (FHIT/7.1850T) S139 & 2196, MAX 600V CSA-C/US HL CLI GRP ABCD CLII GRP EFG CLIII



Twisted Pair:

[CABLE REFERENCE] NVENT-PYROTENAX SYSTEM 1850 TYPE LWMI 300V [# OF CONDUCTORS] [CONDUCTOR SIZE] C(UL)US FOR CT USE DIR BUR, SUN RES, GAS&OIL RES I, II-FRR 2H (FHIT/7.1850) S139, MAX 120V

CSA-C/US TYPES LWMI (CAN) MI (US) HL CLI GRP ABCD CLII GRP EFG CLIII



Shielded Twisted Pair:

[CABLE REFERENCE] NVENT-PYROTENAX SYSTEM 1850 SH TW PAIR TYPE LWMI 300V [# OF CONDUCTORS] [CONDUCTOR SIZE] C(UL)US FOR CT USE DIR BUR, SUN RES, GAS&OIL RES I, II-FRR 2H (FHIT/7.1850) S139, MAX 120V

CSA-C/US TYPES LWMI (CAN) MI (US) HL CLI GRP ABCD CLII GRP EFG CLIII



Jacketed:

Single Conductor:

[CABLE REFERENCE] NVENT-PYROTENAX SYSTEM 1850Z TYPE MI 600V [# OF CONDUCTORS] [CONDUCTOR SIZE] FT4 -40°C C(UL)US FOR CT USE DIR BUR, SUN RES, GAS&OIL RES I, II-FRR 2H (FHIT/7.1850) S139 & 2196, MAX 600V

CSA-C/US HL CLI GRP ABCD CLII GRP EFG CLIII



Multi Conductor:

[CABLE REFERENCE] NVENT-PYROTENAX SYSTEM 1850Z TYPE MI 600V [# OF CONDUCTORS] [CONDUCTOR SIZE] FT4 -40°C C(UL)US FOR CT USE DIR BUR, SUN RES, GAS&OIL RES I, II-FRR 2H (FHIT/7.1850) & FRR 1H (FHIT/7.1850T) S139 & 2196, MAX 600V

CSA-C/US HL CLI GRP ABCD CLII GRP EFG CLIII

UL, UL US, and CLASSIFIED certification marks for multi conductor jacketed cable.

Shielded Twisted Pair:

[CABLE REFERENCE] NVENT-PYROTENAX SYSTEM 1850Z SH TW PAIR TYPE LWMI 300V [# OF CONDUCTORS] [CONDUCTOR SIZE] FT4 -40°C C(UL)US FOR CT USE DIR BUR, SUN RES, GAS&OIL RES I, II-FRR 2H (FHIT/7.1850) S139, MAX 120V

CSA-C/US TYPES LWMI (CAN) MI (US) HL CLI GRP ABCD CLII

UL, UL US, and CLASSIFIED certification marks for shielded twisted pair jacketed cable.

2 Introduction

2.1 General

The MI power cable is manufactured with high conductivity copper conductors embedded in highly compacted magnesium oxide insulation within a robust, ductile copper sheath (Figure 1). This construction and the nature of the inorganic materials used provide MI cables with characteristics that surpass those of other cable types without the need for additional protection such as conduit. One of the most exceptional qualities of MI cable is its fire resistance — the bare cable will not burn, support combustion, propagate flame, or emit smoke or toxic gases.

MI cable can be used for indoor and outdoor applications, either surface mounted or for buried installations in both industrial and commercial installations. It is extensively used for emergency back-up power supply systems, emergency equipment, and fire alarm systems in high-rise commercial buildings, hospitals, tunnels, and airports — in fact, wherever public safety is important. For general information on using and installing MI cable, refer to the National Electrical Code (NEC) or the Canadian Electrical Code (CEC) where applicable.

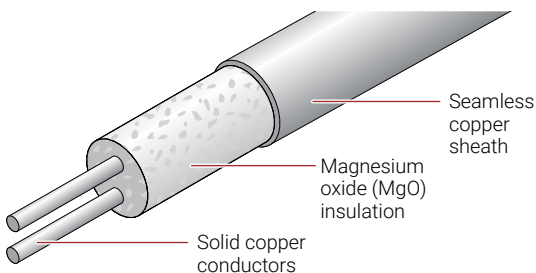

Figure 1: MI cable

2

Introduction

2.2 Typical MI Cable Applications

MI cable may be used in a wide variety of environments. Typical applications of each cable system within a building are shown in Figure 2.

System 1850 2-hour Fire-Rated Cable

The National Electrical Code and Canadian National Building Code recognize critical electrical circuits which, in the event of a fire, must continue to perform their intended functions. NEC Article 695 and Article 700 address “Fire Pump” and “Emergency System” applications respectively. Both require a minimum of a 2-hour fire resistance rating which can be achieved by installing System 1850 MI Cable. System 1850 can be found in the following environments:

- Fire pump feeders
- Emergency generator feeders
- Emergency exhaust fans
- Emergency lighting
- Exit signs
- Firefighter’s elevators
- Emergency communications systems

2 Introduction

System 1850-SE Service Entrance Cable

System 1850-SE is an MI service entrance wiring cable system that allows service entrance conductors to be routed inside the building. In some jurisdictions, the Authorities Having Jurisdiction (AHJs) have accepted this system as an alternative where conditions make concrete encasement difficult or impractical. System 1850-SE can be used for all types of buildings.

2 Introduction

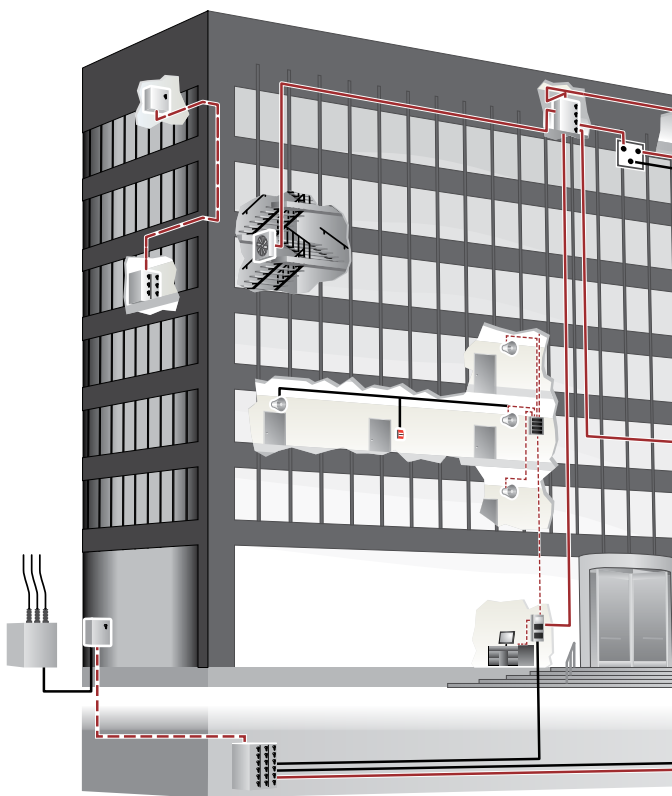

2 Introduction

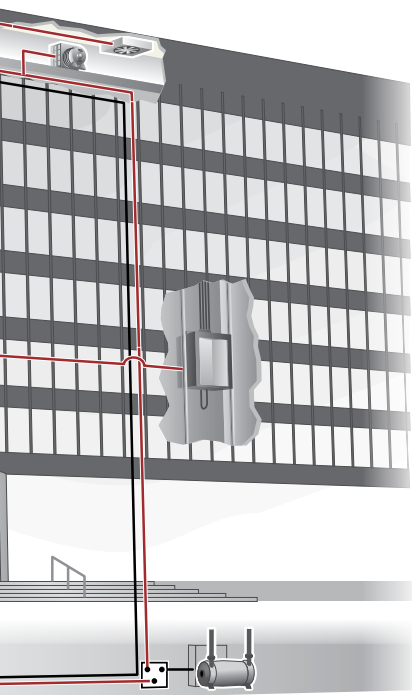

- System 1850
- - - System 1850 Twisted Pair (UL 2 HR Fire Rated - Canada only)
- - - System 1850-SE
- - - System 1850 for Space Savings

Figure 2: Typical MI cable application

2

Introduction

3

Storage and Handling

MI cable is very rugged; however, following the storage and handling measures below will minimize the possibility of damage to the cable.

3.1 Storage

To protect cables from physical damage and the environment, store indoors and protect from moisture, construction equipment, falling objects, chemical spills, moving vehicles, and other hazards.

Initial Inspection

When the cables are received:

- Inspect the protective covering on the cable for evidence of shipment damage.
- Leave the factory-applied protective cover in place until removal is absolutely necessary.
- Where possible, check the copper sheath and, if supplied, the polymer jacket, for evidence of shipment damage.

The MI cables are shipped from the factory with the exposed ends sealed with the factory seal. These covers are weatherproof and seal the cable against moisture and other contaminants during shipment and storage. If the ends are damaged, missing, or removed, check the insulation resistance for the presence of moisture in the cable using a megohmmeter (see Section 6). If moisture is present, follow the instructions in Section 6.2 to remove the moisture or contact nVent for guidance.



Important: After performing "On-Receipt" Insulation Resistance testing (refer to Section 6.1) replace the factory seal and do not remove again until ready to terminate the cable. Ensure cables are re-sealed until ready for final termination.

3

Storage and Handling

Storage Measures

- Store cables and accessories indoors in a dry location.
- Do not stack reels.
- Ensure that both ends of the cable are securely fastened to the reel flange.
- Do not remove the protective factory seal until the cable is ready to be terminated.
- Do not store reels flat. Store reels upright on their flanges (Figure 3).
- Store reels on a firm surface, paved if possible, or on planking to prevent reels from rotting.
- Cover reels with additional protection to shield against the effects of the environment, such as when stored in excessively damp, dirty, or dusty areas.

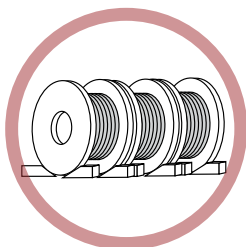

Always load and store reels upright on their flanges and block securely.

Right



Uprighted heavy reels will often be damaged.

Wrong

Figure 3: Store reels upright on flanges

3

Storage and Handling

3.2 Handling

Moving Reels

- Handle or install cables within suitable temperature limits (see Section 4.1).
- Handle in a manner that prevents deterioration of, and physical damage to, the reel and to the cable.
- Handle cable reels utilizing equipment designed for that purpose.
- Do not drop reels from any height, particularly from trucks or other transporting equipment.
- Lift or handle cable reels in such a manner that the lifting/handling device does not make direct contact with the cable or its protective covering.
- Take precautions to ensure that the flange of one reel does not impact the cable on another reel.



Important: If a reel is dropped or damaged or the protective covering is damaged, examine the MI cable.

The following lifting methods are recommended (Figure 4):

- Insert a suitable properly-secured shaft through the reel arbor hole and lift with slings using a crane or boom-type equipment. Use a spreader or other device to minimize sling pressure against the reel flange.
- Move smaller, narrower reels using a forklift. Place fork tines so that lifting pressure is on both reel flanges, not on the cable.

3

Storage and Handling

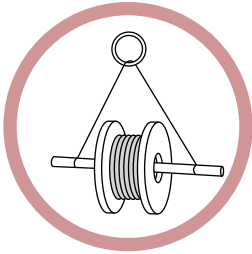

Reels can be hoisted with a properly secured shaft extending through both flanges.



Do not lift by a single reel flange. Cable or reel may be damaged.

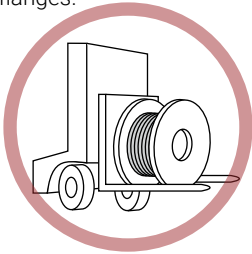

Cradle both reel flanges between fork tines.



Never allow fork tines to touch the cable surface or reel wrap.

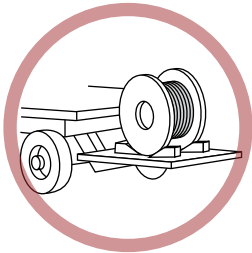

Lower reels from a truck using a hydraulic gate, hoist or fork lift. LOWER CAREFULLY.

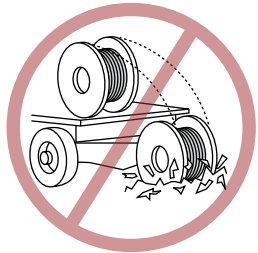

Never drop reels.

Right

Wrong

Figure 4: Reel handling DOs and DON'Ts

3

Storage and Handling

- Roll reels to move them short distances and in the direction so that the cable does not unwind (Figure 5); this will tighten the cable windings, not loosen them. Surfaces over which the reels are rolled must be firm, level, and clear of debris that may damage the cable.

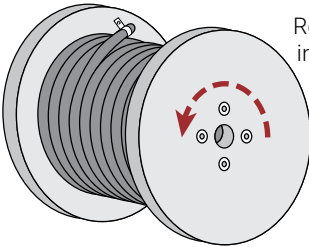

Roll reel in the direction indicated by the arrow.

Figure 5: Reel rolling

Uncoiling Cable

- Do not transfer cable to another reel as it will become work hardened making it less easy to install.
- Uncoil cable with reel or coil in the vertical position by rolling rather than pulling from the periphery or the center of the coil or feed cable from a pay-off-reel (Figure 6). This will greatly ease the handling and prevent possible twisting, bending, and kinking.
- Use appropriate precautions when uncoiling cable (see Section 4.2).
- Handle cable carefully during uncoiling to prevent damage due to kinking or bending to radius smaller than allowable limits.
- Ensure that the cable is not twisted during installation.
- Do not lay cable on rough ground, run over cable, drag cable over sharp objects, or subject cable to other such treatment that could cause damage.
- Do not bend cable to a radius smaller than the minimum pulling radius when uncoiling (see Table 2).

3

Storage and Handling

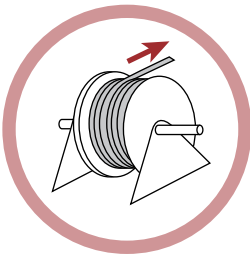

Right

Reel



Wrong

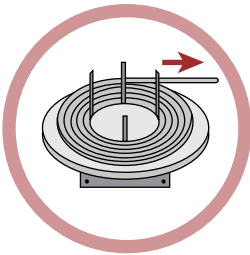

Right

Coil



Wrong

Figure 6: Unreeing/uncoiling cable

4 Pre-Installation

This section deals with factors that should be considered prior to installation. It is highly recommended that cable installations be preplanned. It is important to ensure that personnel are properly trained and qualified for the specific task they are performing. All applicable rules and regulations including federal, state, local, and municipal laws must be followed.

4.1 Minimum Installation Temperature

Due to the fact that cable materials become brittle at low temperatures, a minimum installation temperature of 14°F (-10°C) is recommended for MI cables because this will allow for a considerable degree of rough handling. However, bare MI cable may be installed at a temperature as low as -40°F (-40°C).



Important: When installing polymer-jacketed cables in cold areas, warm in a heated area (at least 50°F (10°C)) for at least 24 hours prior to installation. Install cable promptly after warming.

4.2 Precautions

When installing the MI cables, all appropriate precautions shall be followed, including OSHA and other applicable regulations. Therefore, in addition to observing standard safety practices, observe the following:

- Ensure that the cable reel is properly secured prior to cable installation.
- Use pulling devices and the pull rope within their rating.
- Make sure all equipment is in good operating condition.
- Take appropriate measures to protect personnel in case the pull rope breaks. Personnel shall not stand in line with a pull rope that is under tension.
- Take reasonable precautions to prevent damage to the cable from severe blows with sharp instruments and pulling over sharp objects.

4 Pre-Installation

- Do not pull cables around corners that have sharp edges, such as corners in cable trays, or other obstructions. Use cable sheaves of the proper diameter (see Table 2) or hand feed cables if possible.
- Protect exposed cables from any nearby or overhead work that could damage the cable.
- Do not pull cables around a radius smaller than the minimum pulling radius (see Table 2).

4.3 Installation Equipment

Pulling Equipment

Small diameter MI cables may be installed by hand; however, it is recommended that large diameter MI cables be installed using mechanical pulling equipment that provides a steady continuous pull on the cable. Use pulling equipment with a capacity large enough to handle the maximum allowable pulling tension (see Table 3) on each cable run without causing damage to the equipment or cables. Consult the pulling equipment manufacturer's specifications for capacity limitation.

To prevent damage to the cable during installation, use pulling equipment that can monitor pulling tensions and limit the cable tension to less than the maximum allowable pulling tension. Monitor the pull force for all high tension pulls (such as mechanical pullers, tuggers, and so on) using a tension measuring device.

Sheaves

Use sheaves or pulleys of the proper diameter to avoid damage to the cable (see Table 2).

4 Pre-Installation

Pulling Rope

Use non-stretch pulling rope with swivels between the cable and pulling rope (pull rope diameter and length will depend on the pull to be made and pulling equipment available). Use a pulling rope with a capacity large enough to handle the maximum allowable pulling tension (see Table 3) on each cable run without causing damage to the equipment or cables. Consult the pulling equipment and pulling rope manufacturer's specifications for capacity limitation.

Swivels

To prevent damage to the cable from possible twisting forces imparted when pulling the cable, use swivels between the cable grips and pull rope on all mechanically assisted pulls. The capacity of the swivel shall be large enough to handle the maximum allowable pulling tension on each cable run without causing damage to the equipment or cables. Consult the swivel manufacturer's specifications for capacity limitation.

4.4 Set-up

Before installation, verify that the cable(s) can be installed according to the designed routing and minimum bending radius requirements. Take precautions when routing in close proximity to hot pipes or other heat sources because of ampacity considerations.

Examine trapeze support systems, cable trays, and other support systems for acceptability prior to pulling activities. Install permanent supports properly to ensure the rigidity of the trapeze, cable tray, or other support system so that neither the support system nor the cable will be subjected to damage during the pulling process.

4 Pre-Installation

Minimize the amount of tension necessary to pull a cable as follows:

- Set up the cable reel assembly properly. The first sheave must be installed at a point higher than the support system (Figure 7). The setup shall ensure that the cable is not kinked or bent beyond the minimum pulling radius or subject to excessive twisting force.
- Pull in the proper direction. Where practical, a cable pull should begin nearest the end having the least degrees of bends and exit the end having the greater degrees of bends if at all possible. Also, in vertical sections, an upward pull is preferred.
- Minimize the number and degrees of bends the cable is pulled around under tension. Accomplish this by finding the straightest route possible using the least amount of bends.

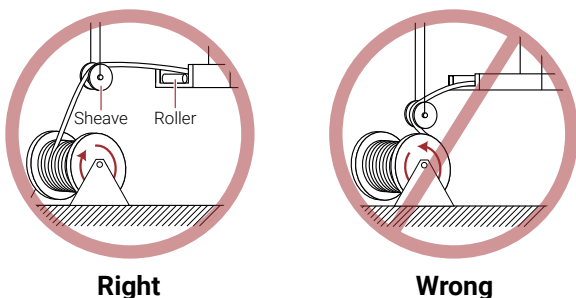

Figure 7: Reel setup

Station an experienced cable pulling observer at the pulling end, in contact (visually, by radio, or by phone) with the other members of the crew. Use a suitable guide device to protect and guide the cable from the cable reel into the trapeze or tray. Make sure that the radius of the feeder device is not less than the minimum pulling radius of the cable. Protect cables exiting the trapeze or tray by similar means.

4 Pre-Installation

4.5 Cable Attachment Methods

Install cable grips and pulling eyes according to the manufacturer's instructions. Form all cable connections to the pulling device in a cylindrical configuration. Do not exceed the maximum allowable pulling tension (see Table 3).

Basket Weave Grips or Split Grips

Use basket weave or split grips to pull cables. Attach the grip to the cable sheath rather than the conductor. Ensure grip is securely fastened to the cable sheath to prevent it from loosening during the pull. Use a swivel between the grip and pulling rope.

Pulling Eye

Attach the pulling eye to the conductors. Use a swivel between the pulling eye and pulling rope.

5 Installation

The information in Section 5.1 applies to all MI cable installations unless otherwise noted. Further installation details that apply specifically to System 1850, System 1850Z 2-hour fire-rated cables and System 1850-SE service entrance cables are shown in Sections 5.2, 5.3 and 5.4 respectively. Following these installation instructions will consistently produce satisfactory MI cable installations.

5.1 General Installation Guidelines

This section covers general installation guidelines that apply to the MI cables.

- Where independent circuits are required or desired, maintain proper separation and segregation from other electrical circuits.
- All conductors of the same circuit, and where used, the grounded conductor (neutral) and all conductors bonding equipment to ground, must be bundled with the cables within a trapeze system or equivalent, unless otherwise permitted in accordance with the NEC/CEC. These requirements apply separately to parallel circuits.
- Protect cables from physical damage. The cable is generally not installed in conduit. Refer to MI cable in the NEC and CEC.
- Metal components and cable sheath must be of materials suitable for the environment in which they are to be installed.
- For concrete encasement, the copper sheath must be covered with a polymer jacket.
- Metal supports, cable sheath, and other metal enclosures for the cables must be metallically joined together and must be connected to all boxes, fittings, and cabinets so as to provide effective electrical continuity.

5 Installation

- Cable shall be pulled in line with the reel. Maintain a slow but steady speed to eliminate galloping (surging) and avoid reverse bending or overrunning. This can be achieved by applying a light back pressure on the cable reel as the cable leaves the reel.
- Conductors to be joined in parallel shall follow the applicable sections of the NEC/CEC.
- Where a single conductor carrying alternating current passes through metal with magnetic properties, the inductive effect shall be minimized by:
 - (a) cutting slots in the metal between the individual holes through which the individual conductors pass.
 - (b) passing all the conductors in the circuit through a brass plate sufficiently large for all of the conductors of the circuit (Figure 14).
- Multiple circuits shall be appropriately spaced for ampacity considerations.
- Ensure that you do not invalidate the listing of the equipment when cutting holes.
- Install cables in accordance with the applicable requirements of the NEC or CEC and all other state/provincial or local codes.

Moisture Absorption

The magnesium oxide insulation of MI cable absorbs moisture when left exposed to air, causing the insulation resistance (IR) to fall. Low IR can be corrected as outlined in Section 6.2.

Expansion and Vibration

When crossing expansion joints, or when connecting the cable to vibrating equipment, it may be necessary to take precautions to prevent mechanical damage to MI cable. See Appendix A for details.

5 Installation

Protection Against Corrosion

Bare copper sheathed MI cable can be used without additional protection for most commercial installations. In an outdoor application where the bare copper cable is in contact with dissimilar metals, wrap rubber tap around the copper MI cables to prevent corrosion at the point of contact with the support structure is recommended.

Equipment Bonding

The copper sheath of MI cable exceeds the code requirements for an equipment-to-ground bonding conductor. However, in the case of fire pump installations using a 600% over-current protective device, a separate equipment-to-ground bonding conductor may be required. Where it is foreseen that the ground continuity may be subsequently impaired by corrosion of the enclosure, it is recommended that the enclosure be suitably protected.

Straightening and Dressing the Cable

The cable is annealed before leaving the factory, making it soft and easy to handle. Prior to securing the cable to a wall or ceiling, the cable may be straightened by hand, or by using the nVent cable straightener (part # STRSM) for cables up to 1/2" OD, or by using the nVent bending hickey (Figure 9). Final dressing may be carried out using a hammer and a block of wood, rubber mallet, etc., as shown in Figure 8. Do not use a metal hammer alone as it may result in unsightly dents that cannot be removed or may cause the cable to fail.

5 Installation

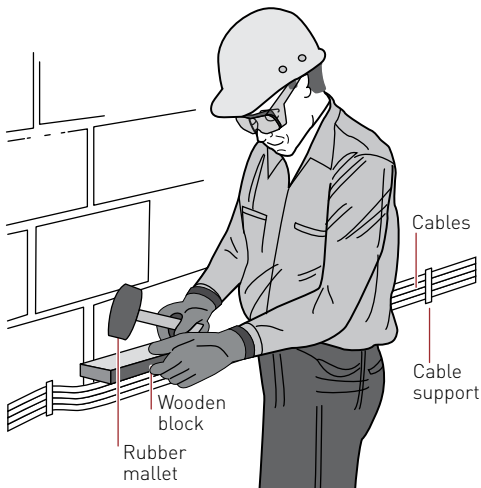

Figure 8: Straightening and dressing MI cable

Bending Radius

All normal bending may be carried out without the use of tools; however, two sizes of bending hickies are available from nVent (refer to System 1850 Tools Data Sheet H57603) for use with the larger diameter cables or when multiple bends are required. These hickies are specially designed to prevent cable damage during bending (Figure 9). Alternatively, a conduit bending tool may be utilized.

When offsetting the cable to enter an enclosure via a gland, 2 to 3 in (50 to 75 mm) of straight cable should be left between the gland and the final bend to facilitate withdrawal of the gland from the enclosure.

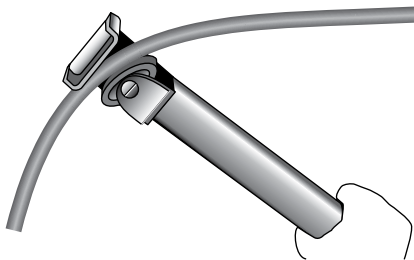

Figure 9: Bending MI cable using a bending hickey

5 Installation

The minimum bending radius for permanent training of the MI cable is shown in Table 1. The relationship between cable diameter and bending radius is shown in Figure 10. Bend in small increments. Do not try to make the entire bend in one operation. Shape into final position gradually.

TABLE 1: MINIMUM BENDING RADIUS

Cable O.D. (Outside diameter)	NEC	CEC
0.75 in (19 mm) and smaller	5 times cable diameter	6 times cable diameter
Larger than 0.75 in (19 mm)	10 times cable diameter	12 times cable diameter

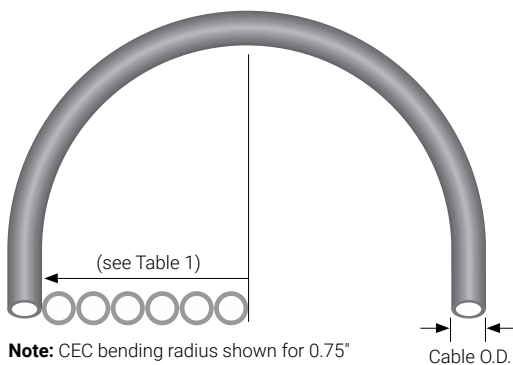

Note: CEC bending radius shown for 0.75" and smaller cables

Figure 10: Minimum bending radius

Pulling the Cable into Position

Pull the cable into position using a series of sheaves or pulleys (Figure 11). This ensures quick and neat installation, especially if a number of cables are being installed along a parallel path. Use the recommended sizes for sheaves or pulleys and observe the minimum pulling radius shown in Table 2 when pulling. Do not exceed the maximum allowable pulling tension shown in Table 3.

5 Installation

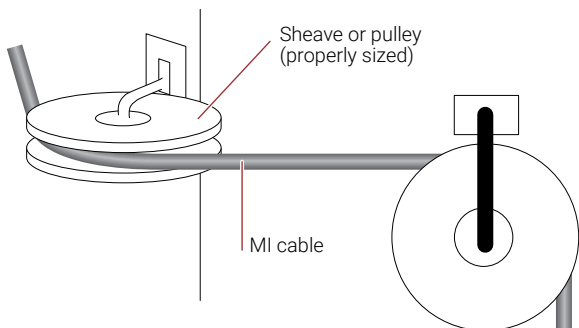

Figure 11: Pulling MI cable

TABLE 2: MINIMUM SHEAVE/PULLEY DIAMETER AND PULLING RADIUS

Cable diameter	Sheave/pulley diameter	Pulling radius
Smaller than 0.5 in (12.7 mm)	10 in (250 mm) or larger	5 in (125 mm)
0.5 to 0.75 in (12.7 to 19 mm)	18 in (460 mm) or larger	9 in (230 mm)
Larger than 0.75 in (19 mm)	24 in (610 mm) or larger	12 in (305 mm)

Maximum Allowable Pulling Tension

When cables are pulled into cable tray or open runs, they are subjected to physical stresses caused by friction of the cable against the supporting and contact surfaces. Cable weight, direction of the pull, and the angle of the pull are all factors that have an effect on pulling tension. The maximum allowable pulling tension for nVent PYROTENAX fire-rated and non-fire-rated MI cables is shown in Table 3.



Important: Factory-welded joints may have a lower tensile strength than continuous cable itself. If your cable has a factory joint, please refer to the proper pulling procedure in nVent document H59040.

5 Installation

TABLE 3: MAXIMUM ALLOWABLE PULLING TENSION (LBS)

System 1850, System 1850Z, and System 1850-SE cables

Cable reference	Cable size AWG/kcmil	Pulling Tension	
		Cable only lbs (kg)	Cable with joints lbs (kg)
Single Conductor			
1/500-1000	500	4200 (1905)	2200 (998)
1/350-834	350	3000 (1361)	2200 (998)
1/250-746	250	2300 (1043)	2200 (998)
1/4/0-684	4/0	2000 (907)	1500 (680)
1/3/0-621	3/0	1600 (726)	1500 (680)
1/2/0-580	2/0	1300 (590)	1300 (590)
1/1/0-512	1/0	1100 (499)	1100 (499)
1/1-496	1	900 (408)	900 (408)
1/2-449	2	750 (340)	750 (340)
1/3-449	3	640 (290)	640 (290)
1/4-402	4	520 (236)	520 (236)
1/6-340	6	370 (168)	370 (168)
1/8-298	8	260 (118)	260 (118)
1/10-277	10	200 (91)	200 (91)

Two Conductor

2/1-975	1	2300 (1043)	2200 (998)
2/2-865	2	1800 (816)	1800 (816)
2/3-768	3	1450 (658)	1450 (658)
2/4-684	4	1100 (499)	1100 (499)
2/6-590	6	800 (363)	800 (363)
2/8-512	8	600 (272)	600 (272)
2/10-449	10	500 (227)	500 (227)
2/12-402	12	350 (159)	350 (159)
2/14-371	14	300 (136)	300 (136)
2/16-340	16	220 (100)	220 (100)

5 Installation

System 1850, System 1850Z, and System 1850-SE cables

Cable reference	Cable size AWG/kcmil	Pulling Tension	
		Cable only lbs (kg)	Cable with joints lbs (kg)
Three Conductor			
3/3-834	3	1900 (862)	1900 (862)
3/4-746	4	1500 (680)	1500 (680)
3/6-621	6	1000 (454)	1000 (454)
3/8-590	8	700 (318)	700 (318)
3/10-480	10	500 (227)	500 (227)
3/12-480	12	400 (181)	400 (181)
3/14-387	14	310 (141)	310 (141)
3/16-355	16	240 (109)	240 (109)

Four Conductor

4/6-730	6	1300 (590)	1300 (590)
4/8-590	8	900 (408)	900 (408)
4/10-590	10	600 (272)	600 (272)
4/12-465	12	500 (227)	500 (227)
4/14-465	14	420 (191)	420 (191)
4/16-387	16	290 (132)	290 (132)

Seven Conductor

7/8-710	8	1200 (544)	1200 (544)
7/10-621	10	1000 (454)	1000 (454)
7/12-543	12	700 (318)	700 (318)
7/14-496	14	500 (227)	500 (227)
7/16-449	16	400 (181)	400 (181)

Twisted Pair Cables*

2/16-246T	16	145 (66)	NA
2/18-215T	18	108 (49)	NA

Shielded Twisted Pair Cables*

2/16-364TS	16	325 (148)	NA
2/18-324TS	18	248 (113)	NA

* **Note:** Twisted Pair and Shielded Twisted Pair Cables are UL 2HR Fire Rated - Canada Only

 **Important:** Because MI cable is delivered in a soft annealed state, the maximum pulling tension must not be exceeded. Exceeding the maximum pulling tension may stretch the cable, resulting in loss of insulation and sheath thickness, and reduced conductor diameter.

5 Installation

Brass Plates

When single-conductor cables enter a ferrous metal enclosure, precautions must be taken to prevent heating by induction. This is done by cutting out a section of the steel enclosure and replacing it with a 1/4 in (6.4 mm) thick brass plate (Figure 12 and Figure 14) at each end of the cable run. Avoid cutting holes in listed enclosures, such as wet-rated and fire pump enclosures, as it might void the enclosure's listing; check with the enclosure's manufacturer if in doubt. When cutting a hole in the enclosure is not allowed, the cables must be terminated into an intermediate box (through a brass plate) and introduced into the listed enclosure through a conventional raceway entry (Figure 13).

Bond the brass plate to the enclosure using a properly sized bonding conductor (refer to NEC/CEC for guidelines). This is achieved by drilling and tapping an appropriate sized hole at a suitable location on the brass plate, and bolting a connector, sized for the bonding conductor, to the plate. The brass plate is not required when installing multiconductor cables.

In the USA, the NEC requires the brass (nonferrous) plate for all single-conductor cables. In Canada, the CEC requires the brass plate only when conductor current exceeds 200 A.



Important: Ensure that enough material remains around the edges of the enclosure to allow the brass plate to be attached to the enclosure as shown in Figure 12.

5 Installation

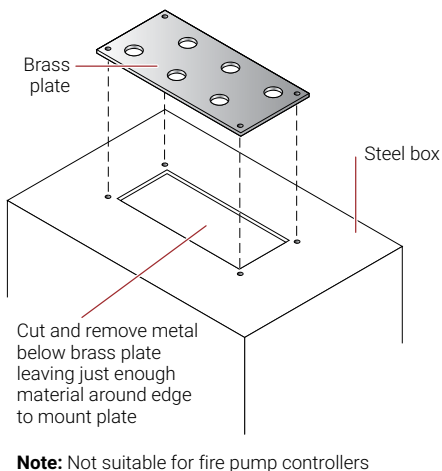

Figure 12: Brass plate installation

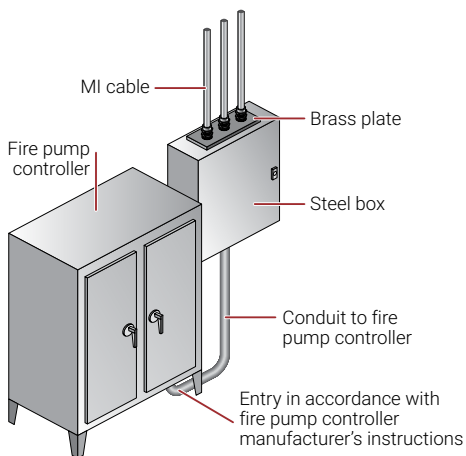
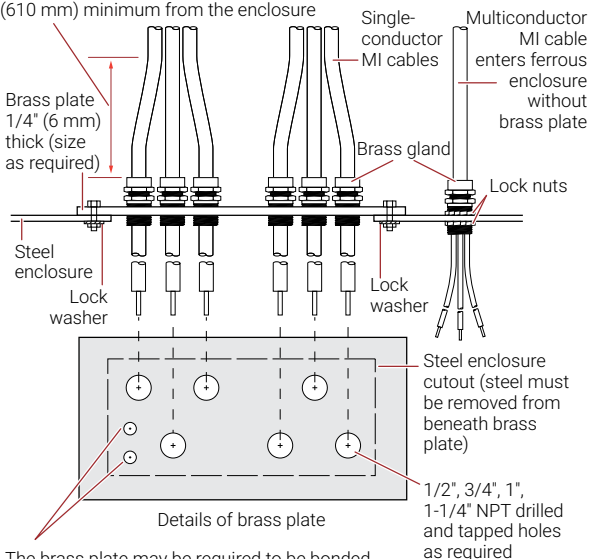

Figure 13: Recommended method of connecting MI cable to fire pump controller

5 Installation

For free air installations as described in the NEC/CEC, the transition from bundled cables must commence 24 in (610 mm) minimum from the enclosure as shown in Figure 14.

For "free air" ratings, the transition from bundled cables must commence 24" (610 mm) minimum from the enclosure



The brass plate may be required to be bonded to the enclosure. Drill and tap the brass plate to accept the bonding connector. For separately derived systems, refer to the NEC

Figure 14: Equipment grounding/bonding using brass plate

Emergency Generator

When connecting MI cable to an emergency generator, terminate the MI cables in an intermediate enclosure through a brass plate. Use flexible cables to make the connection from the intermediate enclosure to the generator.

5

Installation

5.2 Installing System 1850 and System 1850Z 2-Hour Fire-Rated Cable

The instructions in Section 5.2 are for System 1850 2-hour fire-rated MI cable, a 2-hour fire-rated system as classified by UL and listed by ULC. The details of this system appear in the Fire Resistance Directory under Electrical Circuit Integrity Systems (FHIT/FHIT7), System No. 1850. The System listing documents can be provided upon request by your nVent Representative. These requirements must be followed to maintain the 2-hour rating in a fire-rated area.

A typical 2-hour fire-rated power circuit installation utilizing System 1850 MI cable is shown in Figure 15. In addition to the requirements in Electrical Circuit Integrity Systems (FHIT/FHIT7), System No. 1850, these systems must be installed in accordance with all provisions of the NEC/CEC and the requirements in this manual.



Important: Authorities Having Jurisdiction should be consulted in all cases as to the specific requirements covering the installation and use of these classified systems.

5 Installation

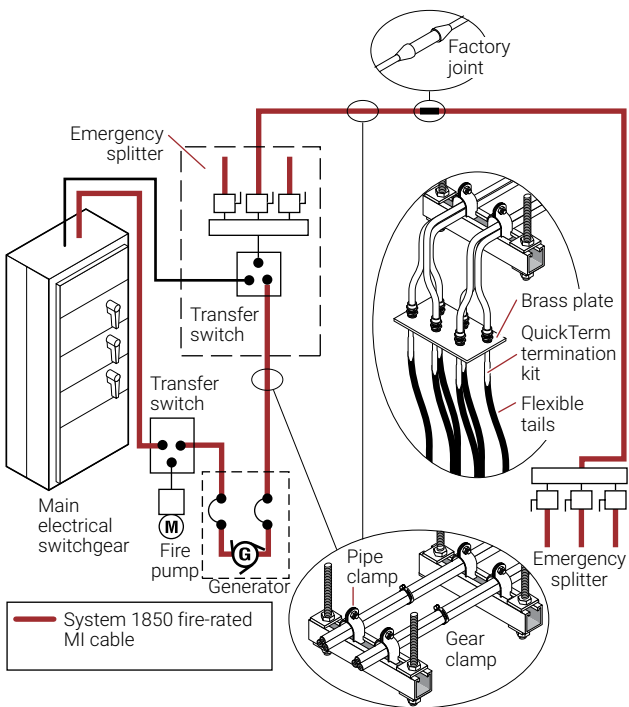

Figure 15: Typical System 1850 2-hour fire-rated power circuit

5 Installation

Single-Conductor Cable

Arrange the cable runs in the configurations shown in Figure 16, Figure 17, and Figure 18. Cables may be run in trifoil or quadrifoil (includes a neutral), or alternatively, side-by-side configuration. The trifoil/quadrifoil configuration is recommended for best sheath current cancellation.

Bundle the cables in groups containing one conductor from each phase with the sheaths touching over the entire length of the run, except when entering the enclosure (see Figure 14). Where parallel runs are required, cable bundles must be spaced distance "S" apart as shown in Figure 16, Figure 17, and Figure 18. If using a separate equipment-to-ground bonding conductor, bundle it within the cable group, and when entering the enclosure, connect it to the brass plate using an appropriate connector and then bond the plate to the enclosure. Follow the requirements of the NEC/CEC as applicable, when installing parallel runs of cable.





Note: Free air ratings do not apply to polymer jacket cable.

	Single Phase
Single circuit (preferred)	
Single circuit (alternative)	
Two cables in parallel per phase (preferred)	
Two cables in parallel per phase (alternative)	
Three or more cables in parallel per phase (preferred)	
Three or more cables in parallel per phase (alternative)	

Note: For free air ampere ratings, the spacing "S" between bundles shall be a min. of 2.15 cable diameters in the U.S. (NEC), and Canada (CEC). For magnetic effect purposes, the neutral may be located as shown, or outside groups in the most convenient location. Free air ratings do not apply to polymer jacket cable.



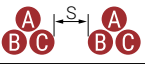
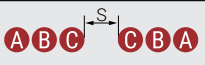
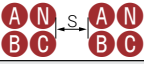
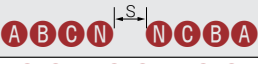

Figure 16: Recommended installation configurations, single phase

5 Installation

	Three-Phase • 3 Wire
Single circuit (preferred)	
Single circuit (alternative)	
Two cables in parallel per phase (preferred)	
Two cables in parallel per phase (alternative)	
Three or more cables in parallel per phase (preferred)	
Three or more cables in parallel per phase (alternative)	

Note: For free air ampere ratings, the spacing “S” between bundles shall be a min. of 2.15 cable diameters in the U.S. (NEC), and Canada (CEC). Free air ratings do not apply to polymer jacket cable.

Figure 17: Recommended installation configurations, three-phase • 3 wire

	Three-Phase • 4 Wire
Single circuit (preferred)	
Single circuit (alternative)	
Two cables in parallel per phase (preferred)	
Two cables in parallel per phase (alternative)	
Three or more cables in parallel per phase (preferred)	
Three or more cables in parallel per phase (alternative)	

Note: For free air ampere ratings, the spacing “S” between bundles shall be a min. of 2.15 cable diameters in the U.S. (NEC), and Canada (CEC). For magnetic effect purposes, the neutral may be located as shown, or outside groups in the most convenient location. Free air ratings do not apply to polymer jacket cable.

Figure 18: Recommended installation configurations, three-phase • 4 wire

5 Installation

On horizontal and vertical runs, MI cable may be supported with steel strut channel as shown in Figure 19.

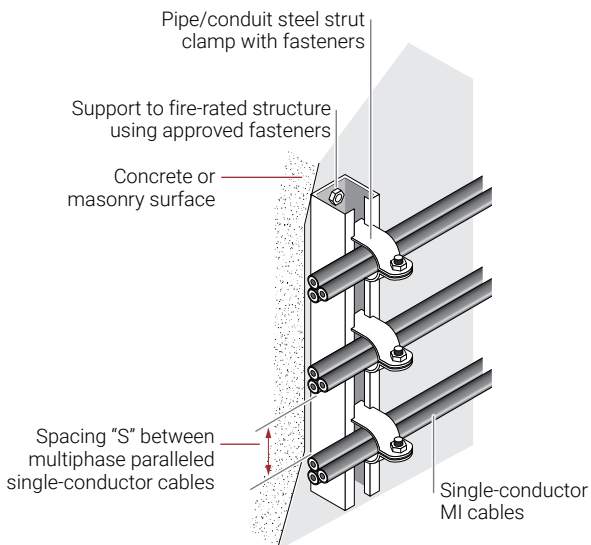

Figure 19: Supporting MI cables using steel channel

Multiconductor Cable

A brass plate is not required for multiconductor cables. Connect the brass termination gland directly to the steel enclosure using lock nuts on either side of the gland connector as shown in Figure 14. Ensure that the brass gland is properly bonded to the steel enclosure once the lock nuts have been tightened. Install multiconductor cables following all applicable requirements in the NEC/CEC.

Twisted Pair Fire Alarm and Communication Cable

System 1850 twisted pair cables are installed in the same manner as multiconductor cables. When installing circuits requiring twisted pair cables, ensure that the cable parameters are compatible with the equipment.

5 Installation

Exposed or Surface Installations

Components used to support System 1850 MI fire-rated cable must be made of appropriate materials such as copper, steel, or stainless steel and attached to a fire-rated surface (such as concrete or masonry) equal to the cable rating.



Important: Do not use material such as aluminum, brass, plastic, lead, wood, etc., since these materials will fail quickly during a fire and jeopardize the integrity of the electrical circuit protective system.



Important: If a fire-rated surface is not available, please contact the local Authority Having Jurisdiction for assistance.



Important: The actual sizes of hangers, bolts, nuts and fasteners are to be adjusted for the weight supported and area seismic conditions. Provide seismic bracing where required. Comply with "System 1850" UL Fire Resistance Directory.

System 1850 MI fire-rated cable must be supported on horizontal and vertical runs by a 2-hour fire-rated assembly, with supports spaced according to the requirements in Table 4.

TABLE 4: MAXIMUM SPACING BETWEEN SUPPORTS AND STRAPS/ GEAR CLAMPS IN FIRE-RATED INSTALLATIONS

Cable diameter	Horizontal/ vertical supports	Straps/gear clamps
0.3 in (7.6 mm) and smaller	4 ft (1220 mm)	2 ft (610 mm)
Greater than 0.3 in (7.6 mm)	6 ft (1830 mm)	3 ft (915 mm)

Install exposed runs of cables parallel to building lines to present a neat appearance as shown in Figure 8. When subject to potentially damaging abuse, protect the cable with angle iron, steel channel, or a short piece of conduit.

5 Installation

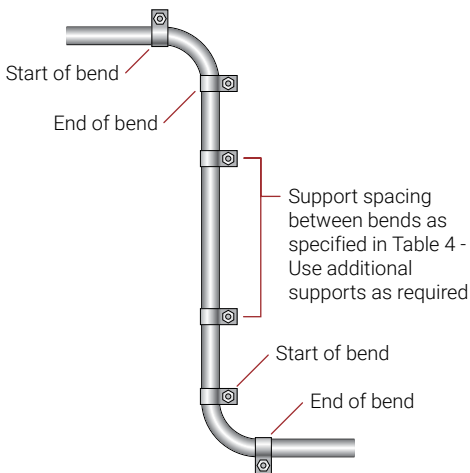

Note: Bends must be supported at the start and end of each bend

Figure 20: MI cable bends

When transitioning from a straight run of MI cable to a bend, use additional supports at the start of the bend and the end of the bend as shown in Figure 20. All cable runs, including bundled cables, must be supported in this manner using the support method being utilized (i.e. trapeze, steel channel, clips and straps, or the banding & bracket system).

Several support methods may be used, as shown following; however, the steel rod and channel (trapeze) system is recommended due to its wide availability and familiarity among installing contractors.



Important: Follow all requirements in Section 5.1 when installing cables.

5 Installation

Trapeze Support

The trapeze support system shown in Figure 21 and Figure 22 must consist of 12 gauge, 1-1/2 in (38 mm) or 1-5/8 in (41 mm) minimum, slotted steel strut channel with hemmed flange edges; width of the steel strut channel must not exceed 36 in (915 mm). Rods must be 3/8 in (10 mm) diameter minimum threaded steel rods with 1-1/2 in (38 mm) steel washers and steel nuts. Securely anchor steel rods to a fire-rated structure, such as concrete or masonry.

Bundle single-conductor MI cables tightly together in groups (see Figure 16, Figure 17, and Figure 18 for configurations) and secure cables in place with 16 gauge minimum steel single bolt pipe clamps, sized to correspond with the outside diameter of the cable or cable bundle (Figure 21 and Figure 22). Table 5 shows recommended loading guidelines for a trapeze-type system that is used to support MI fire-rated cables.

Additionally, bundle each group of cables tightly together between supports using stainless steel gear clamps or using 1/2 in (13 mm) wide by 0.020 in (0.51 mm) thick stainless steel straps in conjunction with 1/2 in (13 mm) wide steel banding clips as shown in Figure 21 and Figure 22. Refer to Table 4 for spacing.

Do not exceed the support spacing shown in Table 4. **Anchors for the trapeze system/tray MUST BE STEEL. Aluminum or other low melting point materials and combustible materials are NOT ACCEPTABLE.**

5 Installation

TABLE 5: LOADING GUIDELINES

Cable load*	Support method
Up to 150 lbs (68 kg)	3/8 in (10 mm) threaded rod
Between 150 and 267 lbs (68 and 121 kg)	1/2 in (13 mm) threaded rod
Between 267 and 400 lbs (121 and 182 kg)	5/8 in (16 mm) threaded rod

Channel

1. Maximum width of 1-1/2 in (38 mm) channel: 36 in (915 mm)
2. Maximum load per channel = 200 lbs (91 kg). Channel may be doubled to increase load to 400 lbs (182 kg) or reduce spacing between supports ensuring that cable load does not exceed 200 lbs/channel.

* Cable load (lbs) = lbs/ft cable x total number of runs x spacing between supports measured in feet
Cable load (kg) = kg/m cable x total number of runs x spacing between supports measured in meters (per pair of rods).



Important: These loading guidelines take into account only the load represented by the MI cable. If the trapeze system will be used to support any other cables, pipes, conduits, etc., the trapeze system must be designed to support the additional load.



Important: Allowance must be made for deflection of the steel channel under fire conditions. A fully loaded, full width channel may deflect (sag) up to 9 in (230 mm). Steel anchors must be used for the threaded rod.

5 Installation

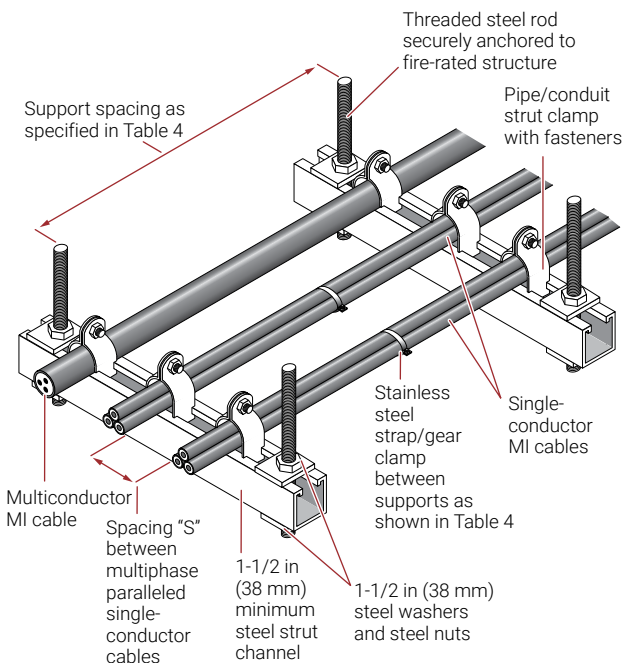

Figure 21: Typical installation using trapeze support – common method

5 Installation

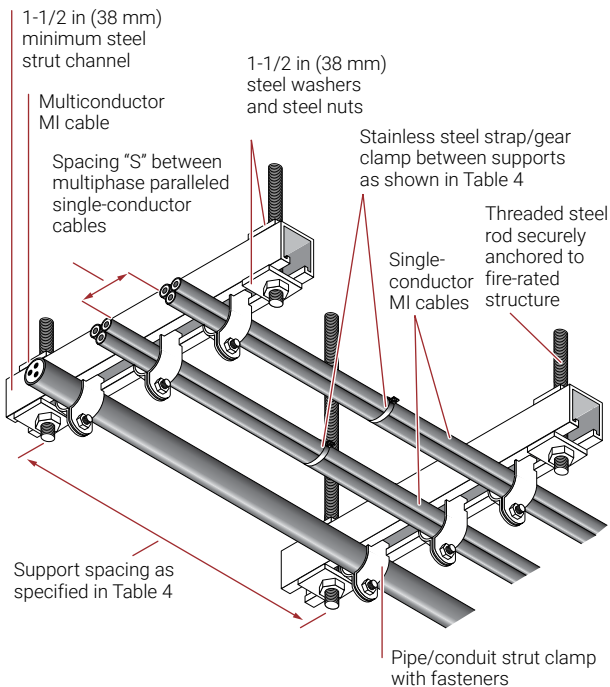

Figure 22: Typical installation using trapeze support – alternate method

5 Installation

Surface Mounted Using Steel Strut Channel

The installation methods shown in Figure 23 and Figure 24 may be used as alternatives to trapeze type support systems.

For surface mounted installations, use 12 gauge, 1-1/2 in (38 mm) or 1-5/8 in (41 mm) minimum, slotted steel strut channel with hemmed flange edges. Securely anchor the steel channel to a fire-rated structure, such as concrete or masonry, using 1/4 in (6.4 mm) diameter minimum by 2-1/4 in (57 mm) long minimum steel concrete screws or other approved fasteners.

Bundle single-conductor MI cables tightly together in groups (see Figure 16, Figure 17, and Figure 18 for configurations) and secure cables in place with 16 gauge minimum steel single bolt pipe strut clamps, sized to correspond with the outside diameter of the cable or cable bundle (Figure 23 and Figure 24).

Additionally, bundle each group of cables tightly together between supports using stainless steel gear clamps or using 1/2 in (13 mm) wide by 0.020 in (0.51 mm) thick stainless steel straps in conjunction with 1/2 in (13 mm) wide steel banding clips as shown in Figure 23 and Figure 24. Refer to Table 4 for spacing. This minimizes sheath currents and stabilizes the cables under short circuit and fire conditions.

Do not exceed the support spacing shown in Table 4.

5 Installation

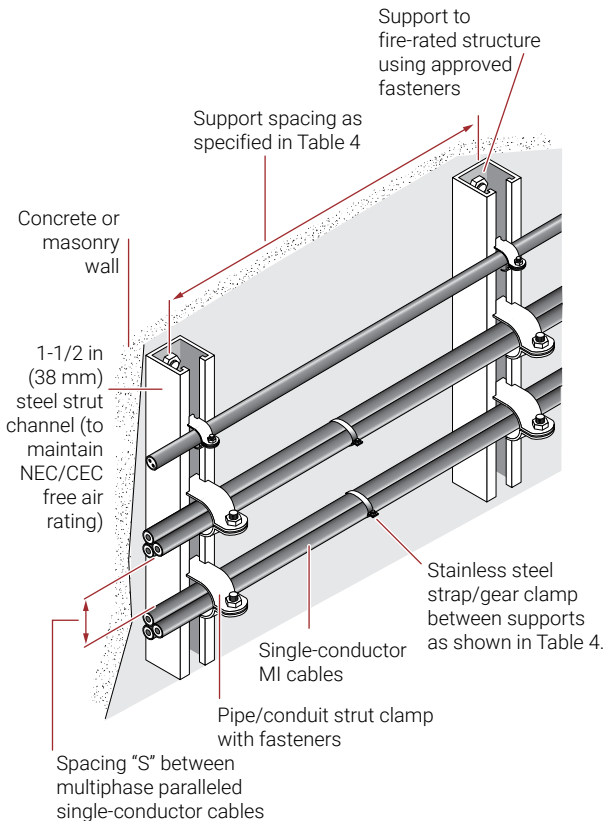

Figure 23: Typical horizontal surface-mounted installation using steel strut channel

5 Installation

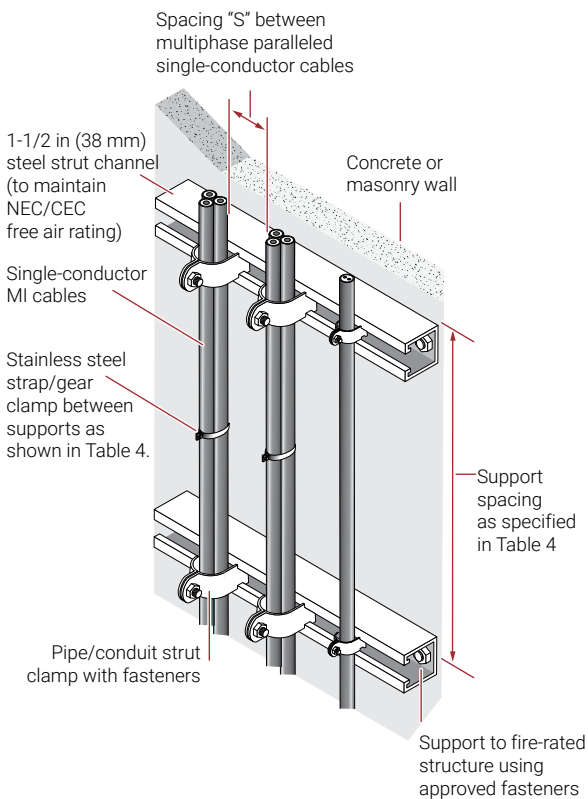

Figure 24: Typical vertical surface-mounted installation using steel channel

5 Installation

Surface Mounted Using Clips and Straps

Support multi-conductor cables directly to concrete or masonry surfaces using 3/8 in to 1 in (9.5 to 25 mm) wide copper clips or straps (Figure 25) available from nVent.

Bundle the MI cables tightly together in side-by-side groups and securely anchor the clips or straps to the structure using 3/16 in (4.8 mm) diameter minimum by 2-1/4 in (57 mm) long minimum steel concrete screws or other approved fasteners.

Do not exceed the support spacing shown in Table 4.

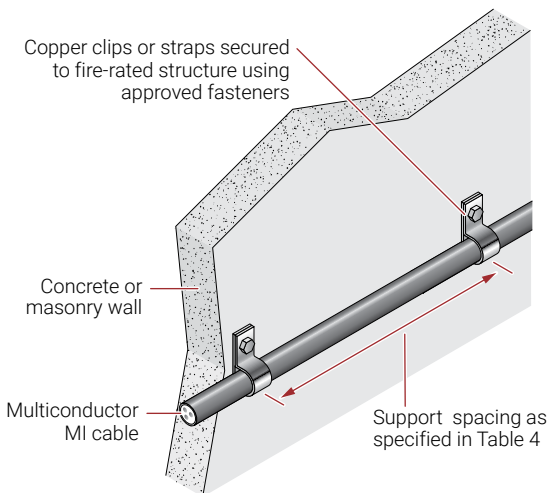

Figure 25: Typical surface-mounted installation using clips or straps

5 Installation

Banding and Bracket Support System

The banding and bracket system shown in Figure 26 and Figure 27 is available from nVent. This method may be used to support a single run of MI cable up to 500 kcmil, 3 bundled runs of cable up to 2/0 AWG, or 4 bundled runs of cable up to 1/0 AWG. The steel bracket is 1 in (25 mm) wide by 4-3/8 in (110 mm) long by 0.125 in (3.2 mm) minimum thickness and stainless steel strapping is 1/2 in (13 mm) wide by 0.020 in (0.51 mm) thick and is held together with 1/2 in (13 mm) wide steel banding clips.

Cut a 10 to 12 in (250 to 300 mm) piece of strapping from the roll, form one end as shown in Figure 26a, and push the other end through the banding clip. Insert the strapping through the two square holes in the hanger, then secure the bracket directly to a fire-rated structure, such as concrete or masonry, using 1/4 in (6.4 mm) diameter minimum by 2-1/4 in (57 mm) long minimum steel concrete screws or other approved fasteners (Figure 26b).

Insert temporary hangers into several brackets (Figure 26c) and fix the cables loosely along the lines they are being installed. Use the hangers to temporarily support the cables. Bundle single-conductor MI cables tightly together in groups (see Figure 16, Figure 17, and Figure 18 for configurations). Band the cables to the bracket with the strapping. Use a tensioning tool to tighten the strapping and crimp the clip in place with a suitable crimping tool (Figure 26).

Additionally, bundle each group of cables tightly together between supports using the stainless steel strapping and clips as shown in Figure 27. Refer to Table 4 for spacing. This minimizes sheath currents and stabilizes the cables under short circuit and fire conditions. Figure 27 shows the completed installation.

5 Installation

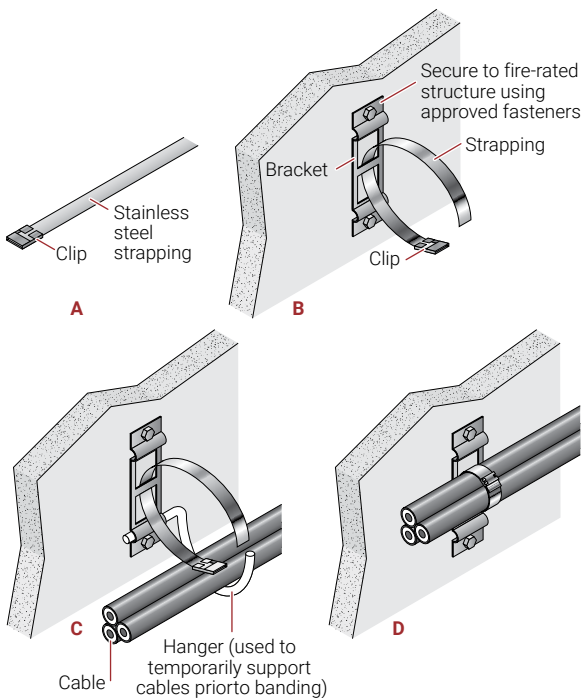
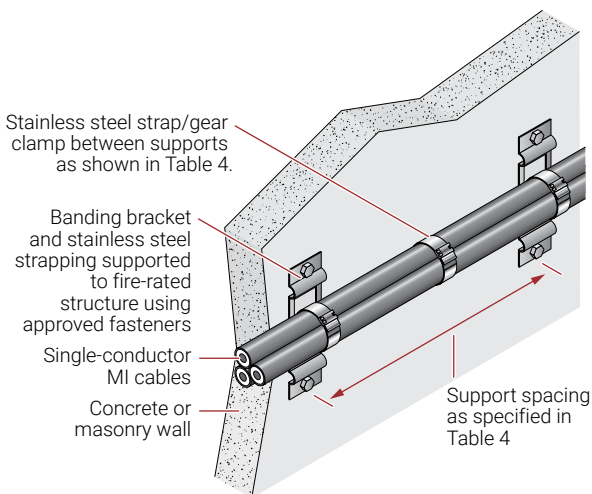

Figure 26: Banding bracket installation

5 Installation



Note: Use to support -
1 run of MI cable up to 500 kcmil
3 bundled runs of cable up to 2/0 AWG
4 bundled runs of cable up to 1/0 AWG

Figure 27: Typical banding and bracket installation for supporting bundled MI cables

Cable Tray

Cable tray, when used to support cable in fire-rated applications, must be solid bottom, open ladder or ventilated trough type steel cable tray capable of functioning at temperatures to 1850°F for a period of two hours. The tray must be rigidly secured to the wall or floor assembly, supported at spacing requirements shown in Table 4, and installed per all national and local electrical codes. Typical "Loading Guidelines" may be found in Table 5.



Important: Trays made of aluminum, galvanized or zinc plated steel, or other low melting point materials are **NOT ACCEPTABLE**. Anchors for tray **MUST BE STEEL**.

5 Installation

Embedded Installations

Cables embedded in concrete must be protected against puncture damage from the medium itself, and the pouring equipment, by means acceptable to the engineer. Where a section of fire-rated cable may be embedded in concrete, the copper sheath must be protected from corrosion by wrapping electrical tape around the cable.

When cables emerge from a slab, protect against shear damage by covering the cables with a short length of metal plate or angle iron, at the point of egress. This protection must extend 18 inches below finished grade to eight feet above finished grade.

Wall or Floor Penetrations

When System 1850 penetrates a wall or floor, place a sleeve in the opening to protect the cable during pulling operations. Once the cable is in place, fill the opening using an approved “fire-stop” system. A list of UL and ULC certified systems appears in the “Through-Penetration Fire Stop Systems” in the Fire Resistance Directory, Guide XHEZ and XHEZC respectively.

Factory-Installed Joint

When the circuit length exceeds the nominal coil length of a particular cable configuration, factory-installed welded joints (FRJ, Figure 28) are supplied for cable diameters of 0.402 in (10.2 mm) and larger.

Where factory-installed welded joints are supplied, reinforcing sleeves are affixed at both ends of every joint to avoid damage to the welds when the cable is pulled into position. Do not exceed the pulling tension shown in Table 3.



Important: Factory-installed joints are only fire-rated for cable diameters of 0.402 in (10.2 mm) and larger.

5 Installation

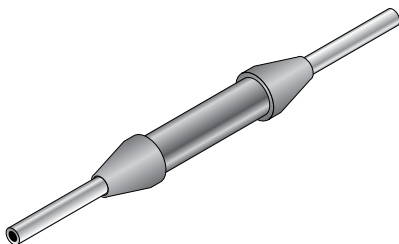
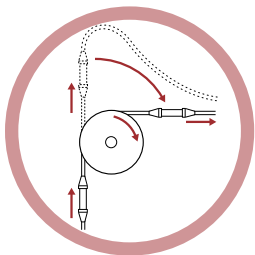
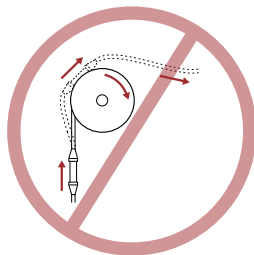

Figure 28: Factory-installed joint (FRJ) for System 1850 MI cable

The proper procedure for pulling cables with factory-installed joints is described in Figure 29. Pull the joint past the sheave/pulley first, then bend the cable around the sheave/pulley by hand and continue pulling the cable. Do not pull the joint directly over a sheave/pulley. Factory-welded joints may have a lower tensile strength than continuous cable itself. If your cable has a factory joint, please refer to the proper pulling procedure in nVent document H59040.



Right



Wrong

Figure 29: Procedure for pulling factory-installed joints

5 Installation

When fastening the joint to a wall or ceiling, support the joint using the banding and bracket method shown in Figure 26. The joint must be supported at its center and 39 in (1 m) on either side of this support as shown in Figure 30.

When using any other method to support fire-rated cables, such as a trapeze system, stagger the joints if possible and ensure that each joint is firmly supported. This can be accomplished by supporting each joint with additional trapeze supports or by securing the joint on top of a section of steel channel and firmly attaching the channel between existing trapeze supports.

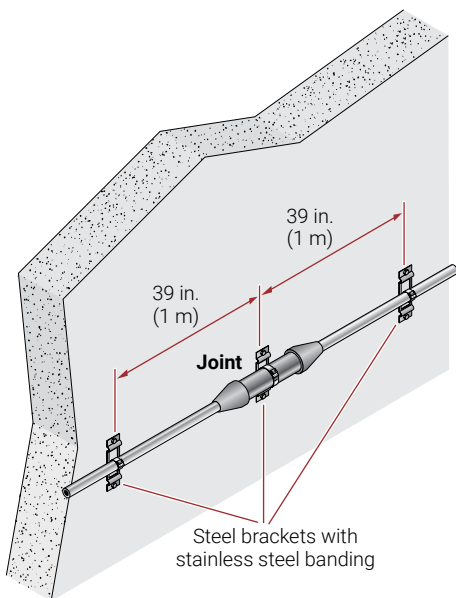



Figure 30: Supporting the factory-installed joint

5 Installation

Field Installed Fire-Rated Splice

When the circuit length exceeds the nominal coil length of a particular cable configuration and factory installed joints are not an option or if a cable is damaged in position, a Field Installed Fire-Rated Splice (FIFRS, Figure 31) is available for all System 1850 cables in order to maintain the 2-hour fire rating. Follow the instructions supplied with the kit to complete the fire-rated splice (H59479: Field Installed Fire-Rated Splice Kit).

 **Important:** System 1850 MI cable must be pulled to splice location and without bends or outer polymer jacket for 4 ft (1.2 m) either side of the planned splice prior to the splice assembly. No pulling is allowed on the finished Field Installed Fire-Rated Splice.

 **Note:** (jacketed cables only): Once the fire-rated splice assembly is complete, approximately 2-1/2 ft (75 cm) of bare cable will be exposed to the environment on either side of the splice.

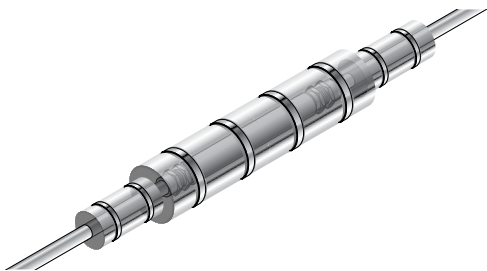

Figure 31: Field Installed Fire-Rated Splice (FIFRS) for System 1850 MI cable

Where Field Installed Fire-Rated Splices are installed, adequate steel structural support must be in place for each finished splice.

One method of support consists of using two 1-5/8 in (41 mm) minimum solid steel strut channels (with hemmed flange edges), 8 in (200 mm) long, mounted (or welded) onto vertical 1-5/8 in (41 mm) minimum wall mounted solid steel strut channels at 90° and spaced 16 to 18 in (410 mm to 460 mm) as shown in Figure 32. Secure wall mounted channels directly to the

5 Installation

fire-rated structure, such as concrete or masonry, using 1/4 in (6.4 mm) diameter minimum by 2-1/4 in (57 mm) long minimum steel concrete screws or other approved fasteners.

Secure the splice to the steel structure using stainless steel banding wrapped around each vertical steel channel. Support the cables on either side of the splice at a maximum of 39 in (1 m) from each wall mounted steel channel as shown on Figure 32, using standard approved system 1850 MI cable supports such as copper clips or banding and bracket system (see details earlier in Section 5.2).

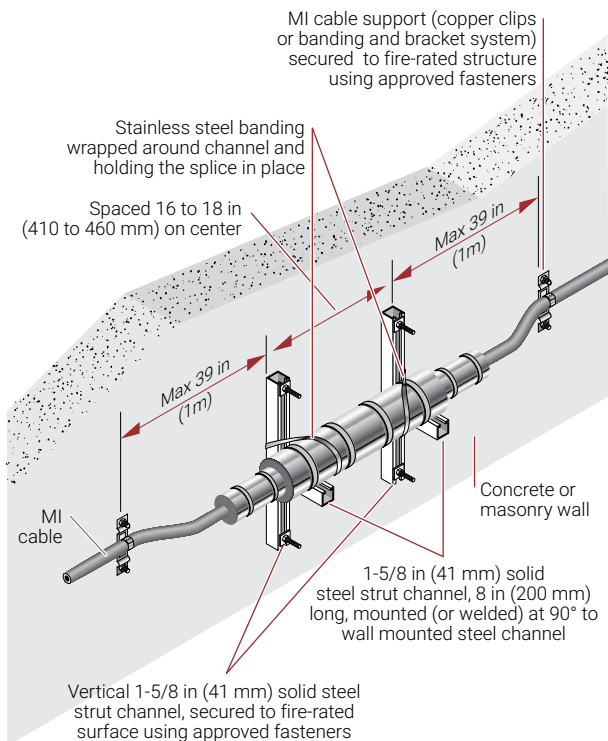

Figure 32: Supporting the Field Fire-Rated Splice using wall mounted steel strut channels

5 Installation

When using another method to support fire-rated cables, such as trapeze system, stagger the Field Installed Fire-Rated Splices if possible and ensure each splice is firmly supported. This is accomplished by using 2 main supports for the splice, spaced 16 to 18 in (410 to 460 mm) on center and an additional support for the cable on either side of the splice at a maximum of 39 in (1 m) from each splice support channel. See Figure 33 for installation details. Follow the trapeze support installation guidelines as described earlier in Section 5.2, including the loading guidelines per Table 5 allowing for the cable weight and an additional 40 lbs (18 kg) for each splice.

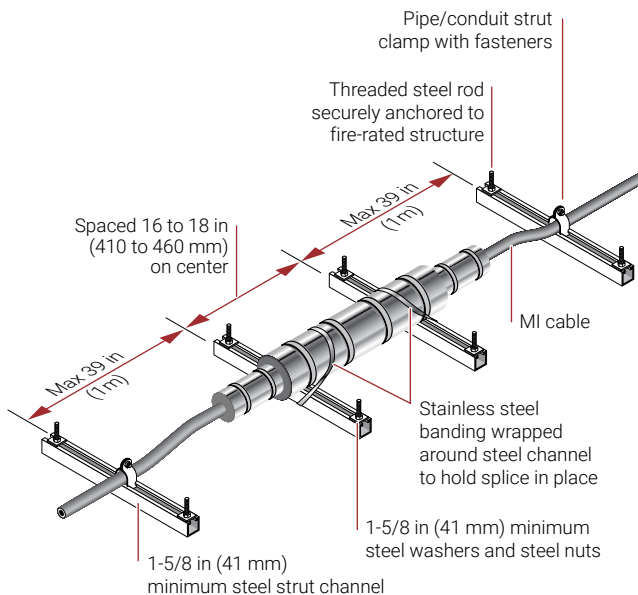

Figure 33: Supporting the Field Fire-Rated Splice using the trapeze support method

5 Installation

Fire-Rated Three-Way Splice (1-hour)

For specialty lighting applications in Tunnels where compliance to NFPA 130 and 502 is required, a field installed Fire-Rated Three-Way Splice (part # FTS, Figure 34) is available for System 1850 Multi-core cables. This system delivers a 1-Hour Fire rating for a fused lighting circuit, eliminating the need for redundant circuits or embedded cables as required for NFPA 130 and 502 compliance. Follow the instructions supplied with the kit to complete the fire-rated three-way splice (H60149: Field installed Fire-Rated Three-Way Splice).

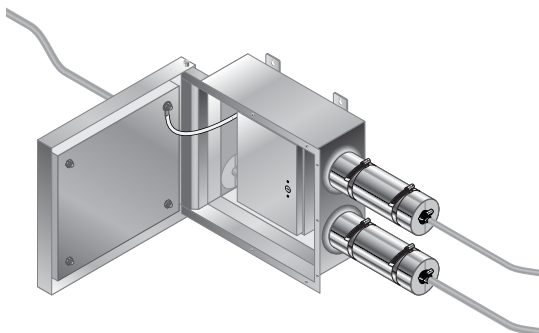

Figure 34: Field installed Fire-Rated Three-Way Splice (FTS) used with System 1850 Cables

Note: (Jacketed Cables only): Once the fire-rated three-way splice assembly is complete, approximately 4 in (10 cm) of bare cable will be exposed to the environment on either side of the splice.

Where a Fire-Rated Three-Way Splice is to be installed, the enclosure must be secured directly to a concrete or masonry structure with a minimum 1-hour fire-rating using 1/4 in (6.4 mm) diameter minimum by 2-1/4 in (57 mm) long minimum steel concrete screws or other approved fasteners.

5 Installation

Support the cables on both ends of the splice at a maximum of 36 in (92 cm) from the edge of the enclosure using standard approved System 1850 MI cable supports such as copper clips or banding and bracket system (see details earlier in Section 5.2).

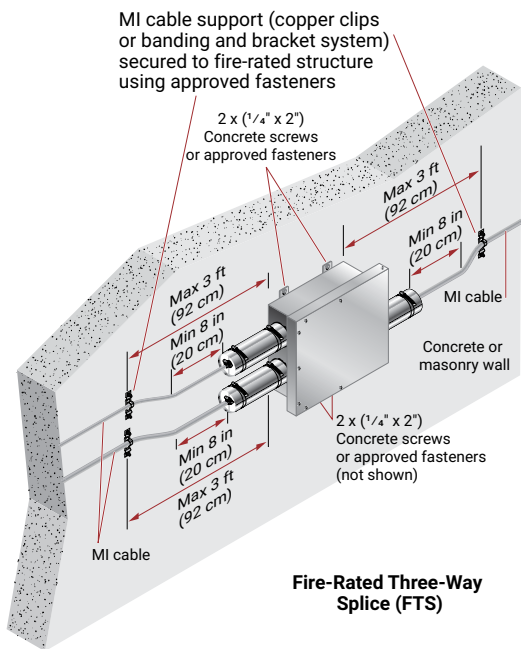

Figure 35: Supporting the Fire-Rated Three-Way Splice

Cable Terminations

System 1850 must be terminated with one of three approved nVent PYROTENAX terminations kits, the QuickTerm kit or the Sized-up QuickTerm kit for single-conductor cables, or the Pyropak kit for single and multiconductor cables (Figure 36). Follow the appropriate installation instruction in the list below to complete the termination. Prior to installing the termination, check the cable with a 500 V megohmmeter, to ensure the IR is acceptable. Refer to Section 6 and the instructions supplied with the termination kit.

5 Installation

Title	Doc No.	Video No.
Quickterm Termination Procedure for Single Conductor MI Power Cables	H58290	H59063
PyroPak Termination Procedure for Multi-conductor MI Power Cables	H58872	H59064
PyroPak Termination Procedure for Twisted, Shielded Pair MI Communication Cable	H59074	H59065
Continuity Testing Procedure for MI Power & Communication Cables	H58872 , Appendix A	H59066
Megger Testing Procedure for MI Power & Communication Cables	Appendix 6.1	H59067
Field Installed Fire-Rated Splice Kit Assembly Procedure	H59479	N/A
Fire-Rated Three-Way Splice Assembly Procedure	H60149	N/A
Pyropak Termination Procedure for Fire-Rated Three-Way Splice MI Cables	H60235	N/A



Important: The System 1850 MI cable terminations must be made outside the fire zone (e.g. fire-rated enclosure or room).

Optional Identification Labels: To help end-users distinguish between System 1850 wiring and copper water supply pipes, install self-adhesive identification labels every ten feet (3 m) on alternating sides of each cable, or each bundle of cables, where the cables are visible or accessible. Catalog number 600VLABEL is designed to be applied directly to the sheath of mineral insulated cables.

5 Installation

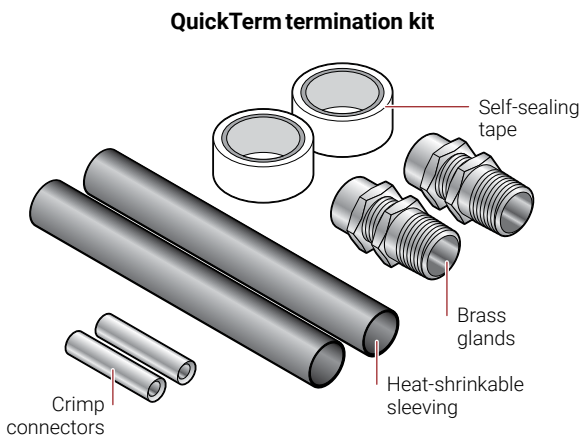
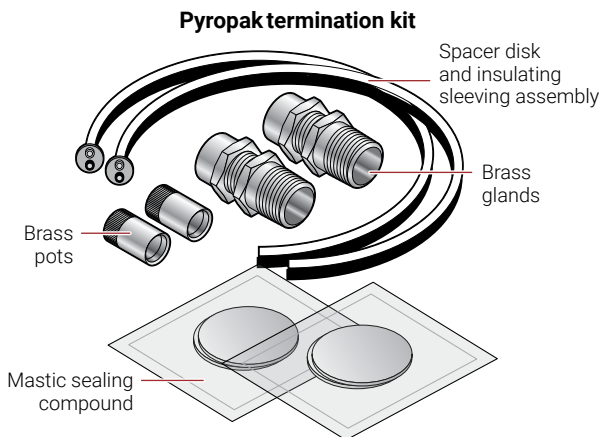

Figure 36: System 1850 termination kits

5 Installation

5.3 Installing System 1850 for Space Savings Non-Fire-Rated Cable

The instructions in Section 5.3 are for System 1850 for Space Savings non-fire-rated MI power cables. These cables are not fire-rated and must not be used where a fire-rating is required. Install System 1850 for Space Savings cables in accordance with all provisions of the NEC/CEC and requirements in this manual. A typical power circuit installation utilizing System 1850 for Space Savings MI cable is shown in Figure 37.

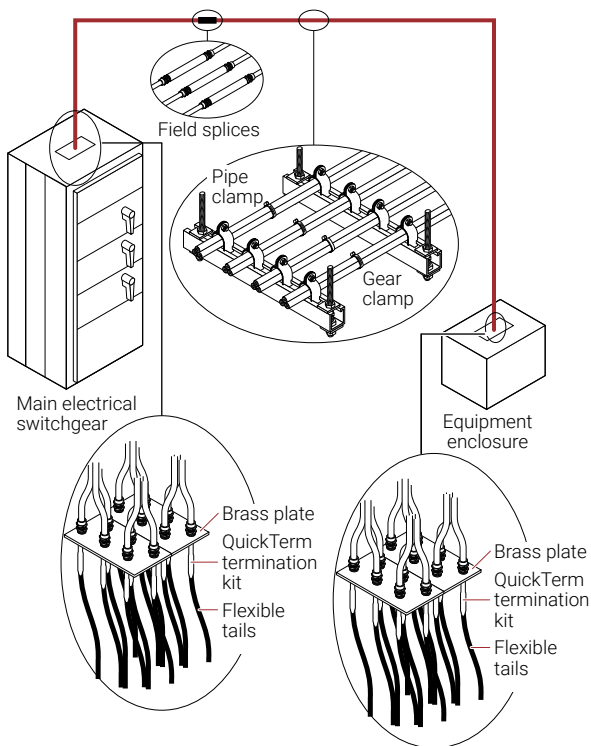

Figure 37: Typical System 1850 for Space Savings power circuit

5 Installation

System 1850 for Space Savings cables may be installed by following the installation details for fire-rated cables shown in Section 5.2, with the following differences:

- Cables may be installed on any surface capable of supporting the cables.
- Required spacing between cable supports is shown in Table 6.

In addition to exposed and surface installations, System 1850 for Space Savings cables may be embedded into plaster walls and easily hidden due to their small diameter.



Important: Follow all requirements in Section 5.1 when installing cables.



Important: The actual sizes of hangers, bolts, nuts, and fasteners are to be adjusted for the weight supported and area seismic conditions. Provide seismic bracing where required.

System 1850 for Space Savings cables must be supported on horizontal and vertical runs according to the spacing requirements in Table 6.

TABLE 6: MAXIMUM SPACING BETWEEN SUPPORTS FOR NON-FIRE-RATED INSTALLATIONS

	Horizontal runs	Vertical runs
USA	6 ft (1830 mm)	6 ft (1830 mm)
Canada	6.56 ft (2000 mm)	6.56 ft (2000 mm)

Factory-Installed and Field-Installed Joints

When the circuit length exceeds the nominal coil length of a particular cable configuration, factory installed joints are supplied. For installation details, refer to Section 5.2. A field installed joint is also available to extend the cable length (Figure 38).

5 Installation

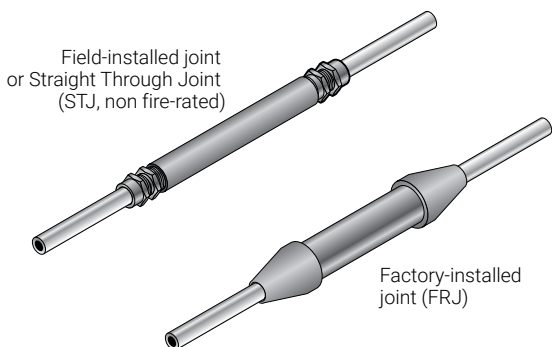



Figure 38: Joints for System 1850 for Space Savings MI cable

Cable Terminations

The cable termination for System 1850 for Space Savings cable is identical to the termination for System 1850 cable. Refer to Section 5.2 for more information on cable terminations.

5.4 Installing System 1850-SE Service Entrance Cable System

The instructions in Section 5.4 are for the System 1850-SE Service Entrance Cable System. The system is designed as an alternative to concrete encasement for service conductors and provides a 2-hour fire-rating. A typical service entrance system utilizing System 1850 single-conductor MI cable is shown in Figure 39.

 **Important: Authorities Having Jurisdiction (AHJs) must be consulted in all cases as to the specific requirements covering the installation and use of the service entrance cable system. In some jurisdictions, the AHJs have accepted this system as an alternative where conditions make concrete encasement difficult or impractical.**

5 Installation

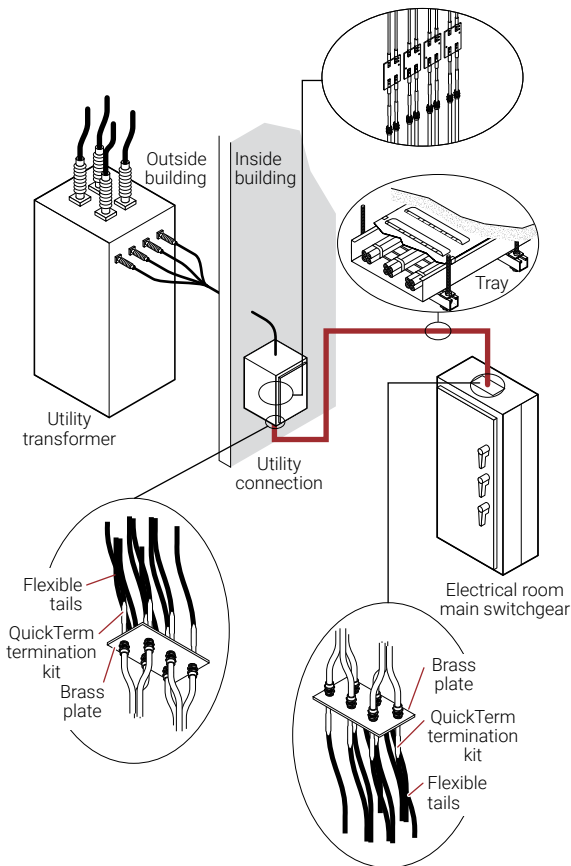

Figure 39: Typical System 1850-SE power circuit

In areas with high levels of thunderstorm activity, the System 1850 cables must be protected with the lightning protection package (Part number: SE-PROTECT). This kit may also be used in any location where there is a concern about lightning activity. Please contact nVent for more information regarding lightning protection for System 1850 cables used in Service Entrance applications.

5 Installation



Important: The SE-PROTECT lightning protection kit must be used in areas where lightning activity is exceptionally high, and may also be used in any location where there is a concern about lightning activity.

Arrange the cable runs in the configurations shown in Figure 40. Bundle the cables in groups containing one conductor from each phase with the sheaths touching over the entire length of the run, except when entering the enclosure (Figure 14). Where parallel runs are required, cable bundles must be spaced distance “S” apart as shown in Figure 40. If using a separate equipment-to-ground bonding conductor, bundle it within the cable group and when entering the enclosure, connect it to the brass plate using an appropriate connector and then bond the plate to the enclosure (see Section 5.1 for further information on using brass plates). Follow the requirements of the NEC as applicable, when installing parallel runs of cable.

Three-Phase • 4 Wire	
Single circuit	
Two cables in parallel per phase	
Three or more cables in parallel per phase	

Note: For free air ampere ratings, the spacing “S” between bundles shall be a minimum of 2.15 cable diameters in the U.S. (NEC).

Figure 40: Recommended installation configurations

Install System 1850 fire-rated cables for service entrance applications only in ventilated steel cable tray (non-galvanized and free of zinc coating), complete with louvered cover, clamps, 90° and 45° bends, offsets, etc. For horizontal runs, support the tray using a steel rod and channel trapeze type system. On vertical runs, support the tray using steel channel directly secured to a concrete or masonry structure using approved fasteners.

5 Installation

 **Important:** Do not support the cable tray using materials such as aluminum, brass, plastic, lead, wood, etc. since these materials will fail quickly during a fire and jeopardize the integrity of the service entrance system.

 **Important:** If a fire-rated surface is not available, please contact the local Authority Having Jurisdiction for assistance.

 **Important:** The actual sizes of hangers, bolts, nuts and fasteners must be adjusted for the weight supported and area seismic conditions. Provide seismic bracing where required.

The cable tray must be supported at intervals dependent on the cable tray loading and the configuration (number of trays, size of trapeze rods). Table 7 gives typical loadings and spacings. For other configurations, contact nVent for the calculated distance between supports, based on the specific installation configuration.

Steel rod and channel trapeze systems, as shown in Figure 41 and Figure 42, may be used to support the cable tray. Trapeze support system must consist of 12 gauge, 1-1/2 in (38 mm) or 1-5/8 in (41 mm) minimum, slotted steel channel with hemmed flange edges; width of the steel channel must not exceed 36 in (915 mm). Rods must be 3/8 in (10 mm) diameter minimum threaded steel rods with 1-1/2 in (38 mm) steel washers and steel nuts. Securely anchor steel rods to a concrete structure.

 **Important:** Install cables following the requirements in Section 5.1, where applicable, and pay special attention to details on bending and pulling the cable. Review the service entrance installation with an nVent Field Services Engineer prior to installing the cables.

Table 7 shows recommended loading guidelines for a trapeze type system that is used to support service entrance cables.

5 Installation

TABLE 7: LOADING GUIDELINES

Configuration for 4-wire system, 500 kcmil MI				
# sets	4 ft spacing		6 ft spacing	
	Rod dia.	No. of channels	Rod dia.	No. of channels
1-5	1/2 in	Single	1/2 in	Single
6	1/2 in	Single	5/8 in	Double
7-8	5/8 in	Double	3/4 in	Double
9	5/8 in	Double	†	†
10	†	†	†	†
11-14	†	†	†	†

1. Maximum width of 1-1/2 in (38 mm) channel: 36 in (915 mm)

† Either support spacing must be reduced or cable tray may be double stacked to reduce load on channel. Contact nVent for assistance.

Configuration for 4-wire system, 350 kcmil MI				
# sets	4 ft spacing		6 ft spacing	
	Rod dia.	No. of channels	Rod dia.	No. of channels
1-5	1/2 in	Single	1/2 in	Single
6-8	1/2 in	Single	5/8 in	Double
9	1/2 in	Double	5/8 in	Double
10	5/8 in	Double	3/4 in	Double
11-14	†	†	†	†

1. Maximum width of 1-1/2 in (38 mm) channel: 36 in (915 mm)

† Either support spacing must be reduced or cable tray may be double stacked to reduce load on channel. Contact nVent for assistance.



Important: These loading guidelines take into account only the load represented by the MI cable. For Service Entrance applications, the cable tray must be used to support only the MI cable. Contact nVent for further information.

5 Installation

 **Important:** Allowance must be made for deflection of the steel strut channel under fire conditions. A fully loaded, full width channel may deflect (sag) up to 9 in (230 mm). Steel anchors must be used for the threaded rod.

Cable Tray Mounted on Steel Trapeze

Support ventilated cable tray at the spacing shown in Table 6 using threaded steel rod and strut channel trapeze system (Figure 41). Bundle cables tightly together in groups (see Figure 40 for configurations) every 2 ft (610 mm) using stainless steel gear clamps or 1/2 in (13 mm) wide by 0.020 in (0.51 mm) thick stainless steel straps in conjunction with 1/2 in (13 mm) wide steel banding clips. Loop the gear clamps or straps through the holes in the bottom of the tray. This will hold the bundles in place and maintain the required spacing “S” between bundles as shown in Figure 38.

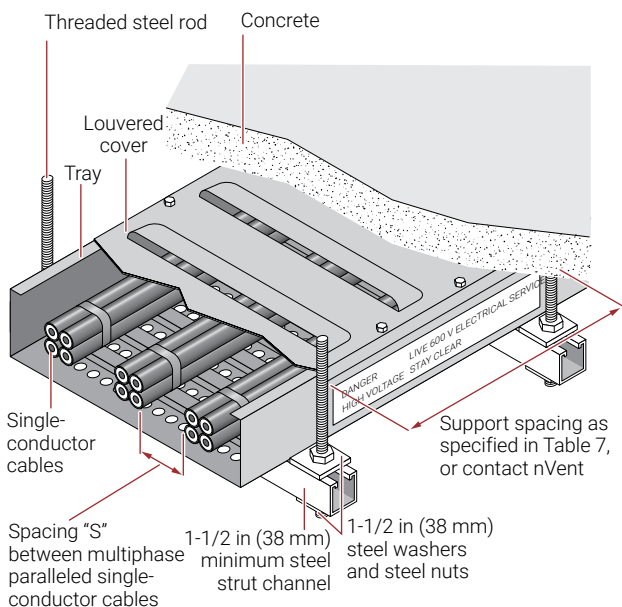

Figure 41: Typical service entrance installation with tray mounted on steel trapeze

5 Installation

Steel Trapeze Mounted Inside Cable Tray

Support ventilated cable tray using steel trapeze system (Figure 42) and at the spacing shown in Table 6. Bundle cables tightly together in groups (see Figure 40 for configurations) and secure cables in place with 16 gauge minimum steel single bolt pipe strut clamps, sized to correspond with the outside diameter of the cable bundle. Maintain the required spacing “S” between the cable bundles as shown in Figure 40. In addition, bundle cables tightly together every 2 ft (610 mm) between supports using 1/2 in (13 mm) wide by 0.020 in (0.51 mm) thick stainless steel straps or using stainless steel gear clamps.

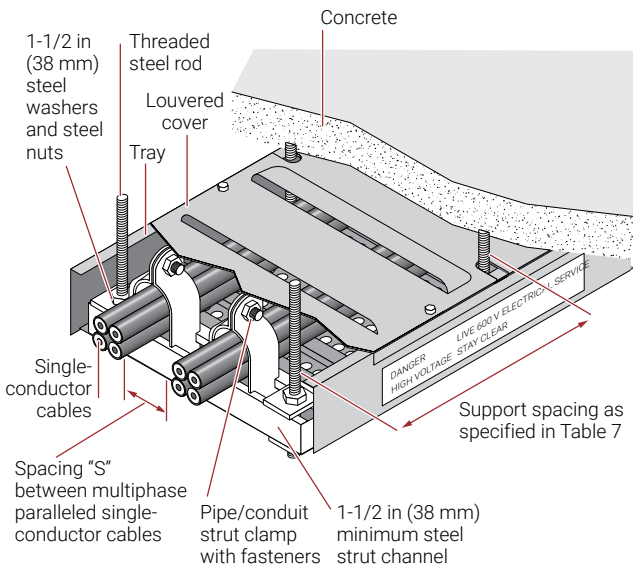

Figure 42: Typical service entrance installation with steel trapeze mounted inside cable tray

5 Installation

Joints

Joints are not acceptable for service entrance applications.

Cable Terminations

The installation instructions for the termination procedure for the System 1850-SE cable system must be reviewed prior to installation and terminations must be installed under the supervision of an nVent Field Services Engineer. A special SE-QuickTerm termination kit is used to splice the solid MI cable conductor to a flexible tail (Figure 43). The mastic sealing compound must be carefully kneaded in and around the open end of the cable, between the conductor and sheath, and then the self-amalgamating tape is applied in accordance with the installation instructions. Refer to Service Entrance QuickTerm Termination Kit Installation Manual, nVent document H58379.

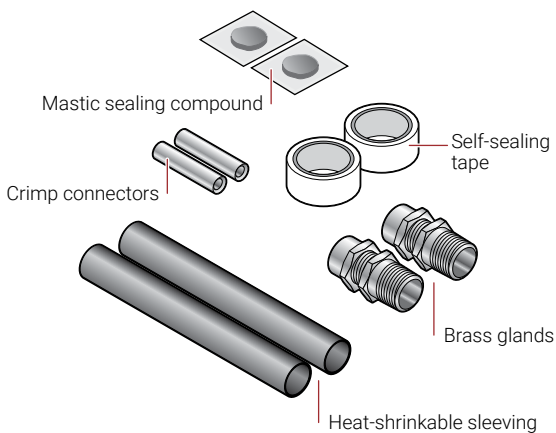

Figure 43: System 1850-SE termination kit

Warning Labels : To satisfy AHJ safety requirements, install self-adhesive warning labels every ten feet (3 m) on alternating sides of the cable tray. Catalog number 600VLABELSE.

5

Installation

5.5 Installation Photos



Back to back 90°



90° Pulley



Horizontal 90° with Pulley

5 Installation



Back to back 90°



Entrance into Box via Brass Plate



Vertical Parallel Runs

5

Installation

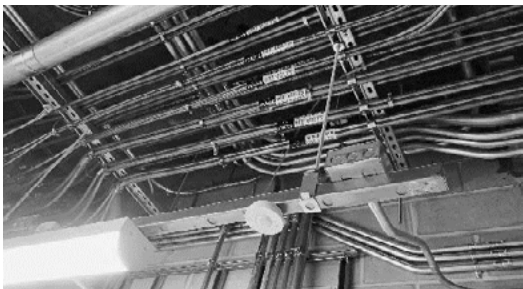

Parallel Runs



Multiple MI Runs



90° Pulley Bends

6 Testing

6.1 Insulation Resistance (IR) Testing

IR testing is conducted using a megohmmeter and tests the integrity of the insulation between the conductors and the cable sheath, and between conductor pairs in multiconductor cables. If the factory seals are damaged, missing or removed, moisture will enter the mineral insulation, resulting in low IR readings. If working with System 1850Z jacketed cable, remove sufficient jacket to allow megohmmeter probes to clamp to copper sheath.

Test Equipment

500 Vdc Megohmmeter (calibrated).

When Received

Check cable on reel. Note that ends may need to be prepared to allow insulation resistance (IR) readings to be taken.

After Installing Termination Kit

- In a warm, dry environment, IR readings should be 200 M Ω or higher.
- In an outdoor environment or indoors in wet or humid conditions, IR readings should all be above 100 M Ω .
- Similar cables exposed to similar conditions should all have IR readings in the same general range. Where a large difference in readings is encountered, high readings can be accepted; low readings (below 100 M Ω) should be checked as described below.

 **Important:** Under some installation conditions it may not be possible to obtain IR readings above 100 M Ω . If IR readings are between 25 M Ω and 100 M Ω , wait 24 hours and recheck the IR using the same equipment. If the IR reading has not decreased, the termination is good – a constant low IR reading can result from moisture entrained in the cable while making a good seal; this moisture will not increase. If the IR reading has decreased, the cable must be re-terminated – a low IR reading can result from a poorly made seal which will allow continuing moisture ingress and the seal must be remade.

 **Important:** If IR readings are less than 25 M Ω , follow the instructions in Section 6.2 to dry out the cable.

6 Testing

Test Procedure

The megohmmeter connections to check the IR of the MI cable between the conductors and the cable sheath, and between conductor pairs are shown in Figure 44. For additional guidance, please refer to the instructional video on our website and YouTube channel (see Section 1.1 for more information).

Insulation Resistance Test

1. Set megohmmeter test voltage at 0 Vdc.
2. Connect the positive (+) (earth) lead to the cable sheath.
3. Connect the negative (-) (line) lead to one conductor.
4. Turn on the megohmmeter and set the voltage to 500 Vdc; apply the voltage for one minute. Meter needle should stop moving. Rapid deflection indicates a short. Note the insulation resistance value. It should be greater than 200 M Ω in a warm, dry environment; greater than 100 M Ω in a wet or humid environment.
5. Turn off the megohmmeter.
6. If testing a single-conductor cable, proceed to Step 7. If testing a multiconductor cable, proceed to Step 8.
7. Testing is complete. If the megohmmeter does not self-discharge, discharge phase connection to ground with a suitable grounding rod. Disconnect the megohmmeter.
8. If testing a multiconductor cable, repeat Steps 3 through 5 for remaining conductors.
9. Next, remove the positive (+) (earth) lead from the cable sheath and connect it to one of the other conductors.

6 Testing

10. Test the cable as in Steps 3 through 5.
11. Repeat for all conductor pair combinations.
12. Testing is complete. If the megohmmeter does not self-discharge, discharge phase connection to ground with a suitable grounding rod. Disconnect the megohmmeter.

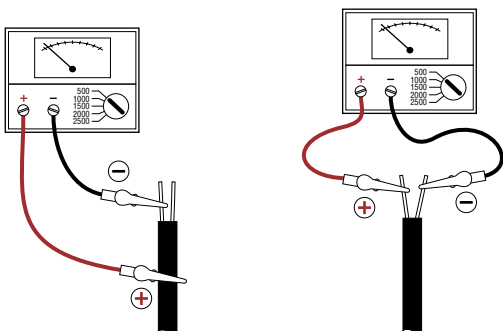

Figure 44: IR test between cable sheath and conductor and between conductor pair

6 Testing

6.2: Improving Insulation Resistance

To maintain the high performance of MI cable, the cable must be properly stored and the ends must remain sealed.

Damaged terminations or factory seals that are damaged, missing, or removed will cause the magnesium oxide insulation (white powder) to absorb moisture, resulting in low IR readings. The cable must be “heated out” to remove the moisture and bring the IR back to an acceptable level. Drying out the MI cable to remove any moisture will normally be unnecessary providing the termination seal is completed within a few minutes of removing the sheath.

With polymer jacketed cables, it will be necessary to peel the covering back prior to “heating out” the cable. Fold it backwards along the cable and use electrical tape to hold it in place to prevent damage while the cable is hot. After the cable has cooled the jacket can be replaced and wrapped with a layer of electrical tape using a 50% overlap (halflaps).

If moisture is found in the cable when checking IR, it may be removed using one of the following methods:

1. If excess cable is available, 6 to 12 in (15 to 30 cm) of cable may be removed from the end before sealing the cable.
2. Apply heat to the cable following the procedure below.



Important: Moisture will not normally penetrate more than 12 in (30 cm) into the cable.

If moisture is detected in the cable, use an oxyacetylene or mapp gas torch with a large flame and “heat out” the cable beginning 12 in (30 cm) back from the end. Gradually move the flame toward and past the cable end. nVent PRYOTENAX copper sheath cables should be heated to a blue color.



Important: When ‘heating out’ MI cable, take normal safety precautions including full face protection.

6 Testing

Use a short sweeping motion of the torch and heat about 2 in (5 cm) of cable at a time, repeating 4 to 5 times (Figure 45). Do not sweep the flame in the opposite direction as this will drive the moisture back into the cable.

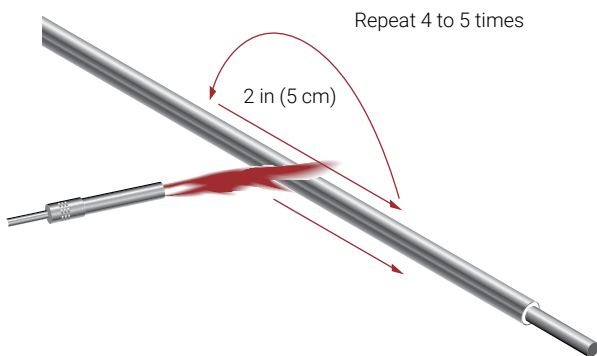

Figure 45: Heat 2 in (50 mm) at a time

Gradually move the flame toward the end of the cable while maintaining the short sweeping motion of the torch (Figure 46). If you heat toward the cable end too quickly you may skip over the moisture and drive it further back into the cable.

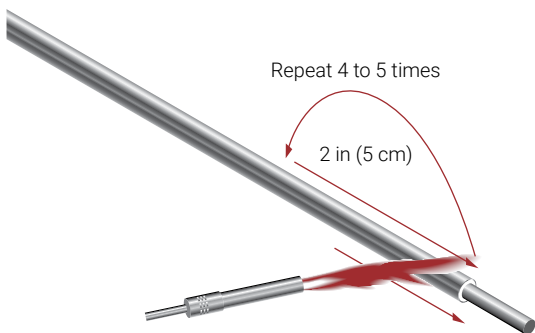

Figure 46: Stroke flame towards end

It may be necessary to repeat the above procedure several times to completely remove all moisture from the cable. Allow the cable to cool before repeating.

6 Testing

The IR of the cables will drop when first heated; however, after the flame has been removed and the cable cools, the IR will increase to an acceptable level if all the moisture has been driven out. On completion, check IR with a 500 Vdc megohmmeter following the instructions in Section 6. If working with shielded twisted pair cable, also test IR between the sheath and inner shield. Reseal cable end with adhesive lined heat shrink tubing if not ready to terminate cable.

6

Testing

6.3 Mineral Insulated Wiring Installation Record

This record is intended for use by the installer or commissioning agent as a record of various installation parameters. It is the responsibility of the Electrical Inspector to verify compliance with codes and standards. Please complete the online form to register your installation for the extended warranty program. To view warranty information and complete the online form to register your installation for the extended warranty program visit <https://pyrotenax.nvent.com/en-ca/warranty-information>.

Form Completed By:

Installer Engineer End-User

Purchased from: _____

Address: _____

City: _____ State/Province: _____

INSTALLATION LOCATION

Project Name: _____

Address: _____

City: _____ State/Province: _____

Postal/ZIP Code: _____ Phone: _____

Installation Environment:

Commercial Industrial Hazardous

INSTALLED BY

Company: _____

Address: _____

City: _____ State/Province: _____

Postal/ZIP Code: _____ Phone: _____

Installer's Name: _____

Megohmmeter ID Number: _____

Megohmmeter Calibration Due Date: _____

6

Testing

Project and Application Details

(please check all that apply)

- Fire-Rated Application (System 1850)
- Service-Entrance Application (System 1850-SE)
- Non Fire-Rated Application (System 1850 for Space Saving)
- Fire-Alarm Application (System 1850 Twisted Pair)
- QuickTerm Termination Kits
- PyroPak Termination Kits
- New Construction Retrofit Repair
- Office Healthcare Other Institution
- Transit

nVent Tools Used (please check all that apply)

- Sheathmaster Ratchet Stripper
- Pyropotter Tool
- MIC Handle Crimper CC Screw Crimper
- Handvise Small Bending Hickey
- Pyrohickey STRSM Cable Straightener

Visual Inspection (Upon receipt)

Date: _____

- MI Cable sizes, and sheath outer diameters match system documentation and purchase order.
- MI Cable Sheath appears to be free of damage
- MI Cable Joints (if applicable) appear to be free of damage
- MI Cable Temporary End Seals appear to be intact
- MI Cable Reels have been handled and stored according to published guidelines
- IR Testing has taken place after the items above have been verified

If you notice any material damage upon receipt, notify your supplier immediately.

Record Test Results for each circuit on the table on the next page. Keep this booklet somewhere safe! You will need it for subsequent testing and for your warranty report.

6

Testing

Visual Inspection (After pulling)

Date: _____

- MI Cable pull did not exceed published tension limits
- MI Cable sheath appears to be free of significant scrapes, dents, twisting, or other potential cold-work damage
- MI Cable has been dressed using nonmetallic tools
- MI Cable bend radius exceeds published minimum in all cases
- MI Cable is arranged according to published configurations along all lengths
- Cable supports meet applicable NEC/CEC fire-rating requirements
- Cable supports meet NEC/CEC spacing requirement
- IR Testing has taken place after the items above have been verified

nVent Field Support Technicians and Engineers are available to assist with installation inspections. Contact your local representative to coordinate.

Visual Inspection (After Termination)

Date: _____

- MI Cable termination is properly bonded (if applicable)
- Warning Labels have been installed
- Conductors have been properly identified prior to connection
- IR Testing has taken place after the items above have been verified

nVent Field Support Technicians and Engineers are available for Field Termination Training, and system installation inspections. Contact your local representative to coordinate.

Please complete this record and register your installation online.

6

Testing

Cable Reference (size, #conductors)	Factory Batch Number (see tag or reel)	Source Side Equipment/ Panel, Room	Load Side Equipment/ Panel, Room	Run Length (ft)	Insulation Resistance (IR) Test Reading: Upon Receipt (MΩ)	IR Test Reading: After Pulling (MΩ)	IR Test Reading: After Termination (MΩ)
Example: 1/1-496, single	Example: Sales Order 381131	Example: Generator A, Penthouse	Example: "Fire Pump", or "Emergency Panel in P1 Electrical Room"	Example: 300 ft	Example: 825 MΩ	Example: 613 MΩ	Example: 417 MΩ

6

Testing

Cable Reference (size, #conductors)	Factory Batch Number (see tag or reel)	Source Side Equipment/ Panel, Room	Load Side Equipment/ Panel, Room	Run Length (ft)	Insulation Resistance (IR) Test Reading: Upon Receipt (MΩ)	IR Test Reading: After Pulling (MΩ)	IR Test Reading: After Termination (MΩ)

Appendix A: Expansion and Vibration

The electrical properties of MI cables are not affected by vibration, but precautions should be taken to prevent mechanical damage to the cable where it crosses expansion joints or where vibration is present.

Conditions encountered in commercial applications can be satisfied by providing, between securing clips or other fixation methods, a right angle bend (Figure B1), two right angle bends (Figure B2), or one semicircular bend (Figure B3) in the cable, whichever is most appropriate for a particular installation.

When crossing an expansion joint, or when the termination for single-conductor cables will be subjected to vibration, a semicircular bend as shown in Figure B3 is recommended. Where the termination for multiconductor cables is subjected to vibration, an expansion loop as shown in Figure B4 is recommended. In cases of severe differential vibration, the cable must be terminated into a junction box adjacent to the vibrating equipment and the final connection made via a flexible conduit and/or cable.

The bending radius must not be less than six times the cable diameter for cables up to 0.75 in (19 mm) diameter and 12 times the cable diameter for cables greater than 0.75 in (19 mm) diameter.

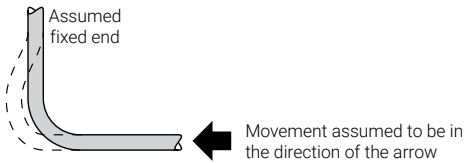

Figure A1: Single right angle bend

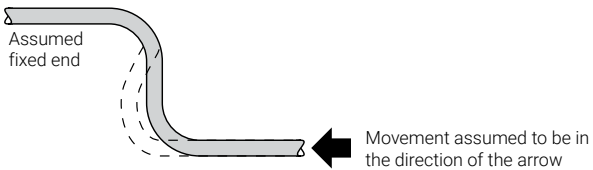

Figure A2: Two right angle bends

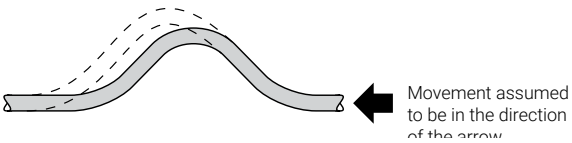

Figure A3: One semicircular bend

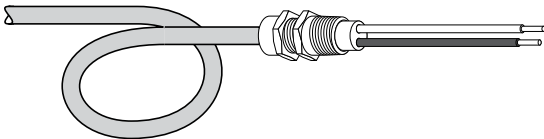
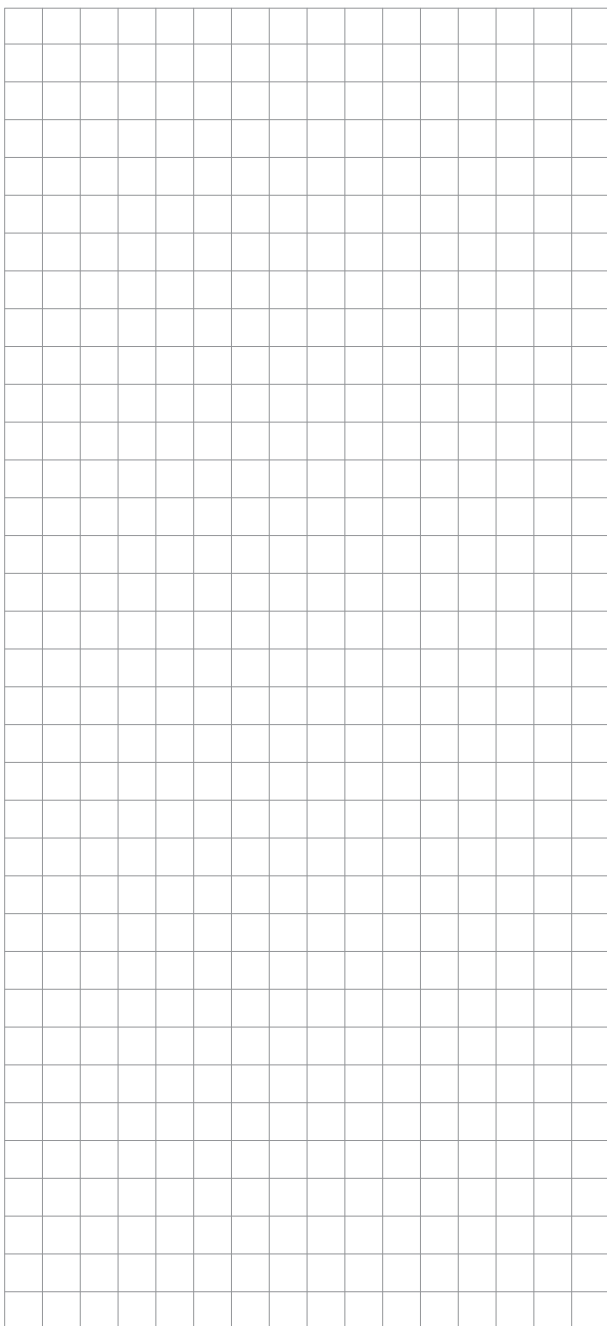

Figure A4: Expansion loop on termination end

7

Appendix

7 Appendix



7

Appendix

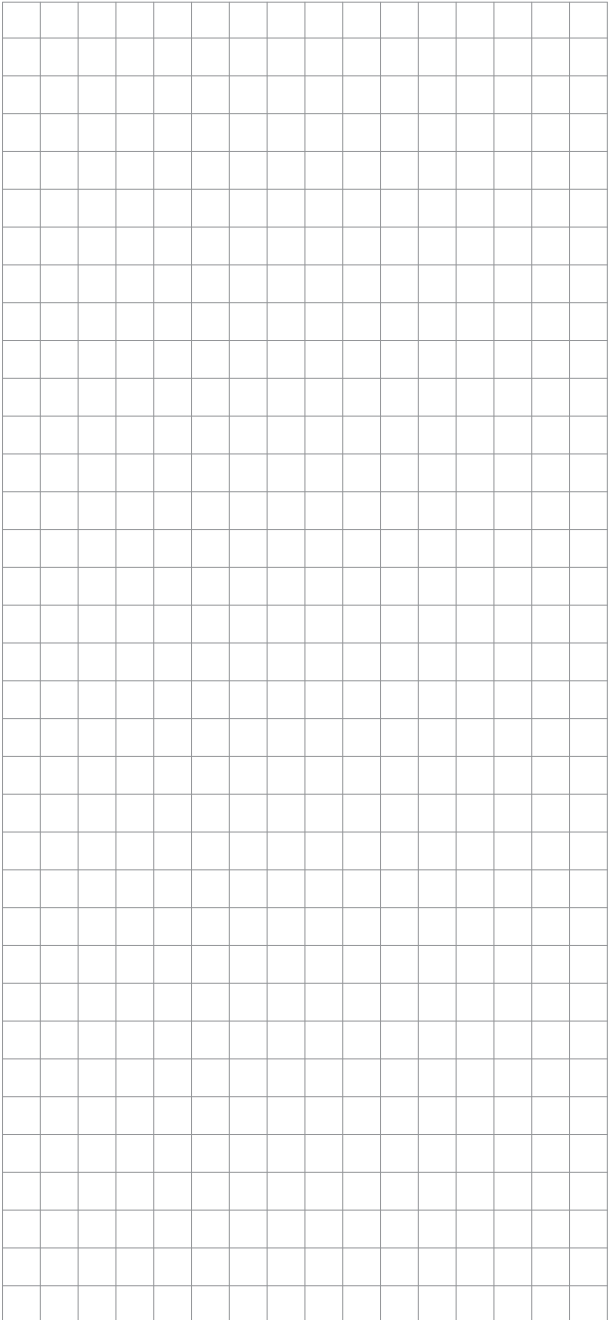

North America

Tel: +1.800.545.6258

Fax: +1.800.527.5703

thermal.info@nvent.com



nVent.com/PYROTENAX

© 2023 nVent. All nVent marks and logos are owned or licensed by nVent Services GmbH or its affiliates. All other trademarks are the property of their respective owners. nVent reserves the right to change specifications without notice.

PYROTENAX-IM-H57864-MIcommercialwiring-EN-2308