

Cold applied connection and splice kit with silicone sealing for Polymer Insulated (PI) heating cables

PRODUCT OVERVIEW

The conductor crimp is not included in the kit and has to be ordered separately.

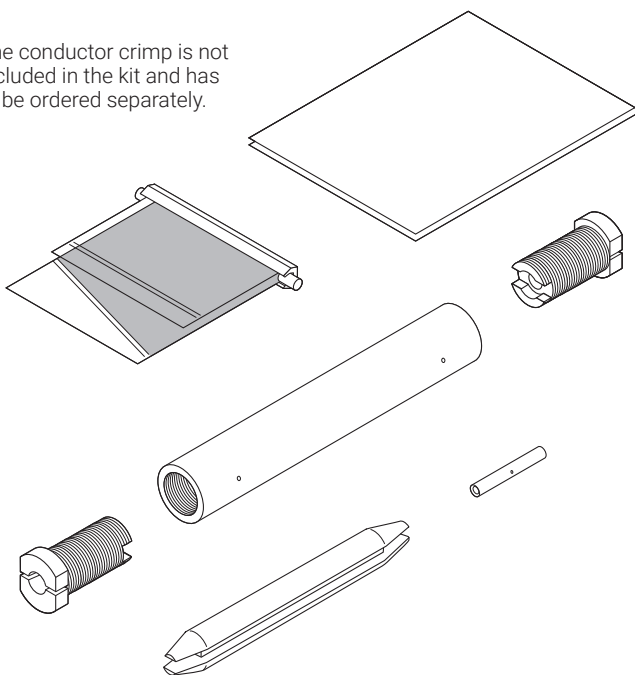

The kits nVent RAYCHEM CS-150-xx-PI are designed to connect a PI cold lead cable to a polymer insulated (PI) series heating cable as well as to splice two PI heating cables. The kit employs a two component silicone compound to provide durable and flexible moisture proof encapsulation.

Electrical continuation is maintained via specially engineered crimps that provide a highly reliable electrical connection.

It is very important that the electrical crimp connections are performed with the correct crimp tool (PI-TOOL-xx).

Due to its low profile design, the connection can be easily installed under the insulation directly on the pipe. If used as a connection kit, a cable gland, an insulation entry kit as well as a crimp for the connection between the cold lead and the heating cable, need to be ordered separately. If used as a splice kit, just the heating cable conductor crimp is needed additionally.

For simplified installation- and maintenance work, we offer a crimp toolbox that contains the suitable installation tool, crimping dies and a variety of crimps exactly matching common cable types. For all details concerning the crimping system, refer to the datasheet of the electrical connection system for PI heating cables (PI-TOOL-SET-xx).

Application

Cold applied silicone sealed connection/splice for PI heating cables.

Kit contents

- 1 x PTFE body
- 2 or 3 x PTFE plugs (depending on kit)
- 1 x PTFE crimp separator
- 1 x two component silicone compound in plastic bag (shelf life is 12 months)
- 2 x braided crimps
- 1 x identification label
- 1 x multilingual installation instruction

PRODUCT SPECIFICATIONS

Dimensions (in mm)

CS-150-2.5-PI: Overall length ~120 mm, Ø ~17 mm

CS-150-6-PI: Overall length ~120 mm, Ø ~26 mm

CS-150-25-PI: Overall length ~135 mm, Ø ~35 mm

Technical details

	CS-150-2.5-PI	CS-150-6-PI	CS-150-25-PI
Max. operating temperature	200°C continuous, (260°C intermittent)		
Min. installation temperature	-50°C		
Max. operating voltage (U0/U)	450/750 Vac nominal		
Max. operating current	Only limited by heating cable used		
Cable/Cold leads	Up to 2.5 mm ²	4 to 6 mm ²	10 to 25 mm ²

APPROVALS

For use in ordinary and hazardous area Zone 1 and Zone 2 (Gas), Zone 21 and Zone 22 (Dust)

Temperature classification

Temperature classification is defined by the complete system.

Product certification



More details about product certification, approvals and conditions of safe use are available in the installation manual at www.nVent.com/RAYCHEM.

ORDERING INFORMATION

Order reference	CS-150-2.5-PI	CS-150-6-PI	CS-150-25-PI
Part number (Weight)	1244-000586 (0.1 kg)	1244-000588 (0.2 kg)	1244-000587 (0.3 kg)

Accessories

Cable gland for PI connection kit (one per piece of cold lead connection; to be ordered separately)	C20-PI-PA-KIT Hazardous area approved gland, PA, up to -40°C
	C20-PI-M0-KIT Hazardous area approved gland, Ni plated brass, up to -55°C (to be used with boxes with integral earth plate or with earth lug)

North America

Tel +1.800.545.6258

Fax +1.800.527.5703

thermal.info@nVent.com

Europe, Middle East, Africa

Tel +32.16.213.502

Fax +32.16.213.604

thermal.info@nVent.com

Asia Pacific

Tel +86.21.2412.1688

Fax +86.21.5426.3167

cn.thermal.info@nVent.com

Latin America

Tel +1.713.868.4800

Fax +1.713.868.2333

thermal.info@nVent.com



Our powerful portfolio of brands:

CADDY ERICO HOFFMAN RAYCHEM SCHROFF TRACER