

CABLERACK

INDUSTRY STANDARDS

UL 2416 Listed; File Number E230874
Rated to 60 lbs. with a 4X safety factor

EIA 310-D

APPLICATION

CABLERACK is used for ladder or basket tray mounting and securing 19-inch rack equipment for network, server, and telecommunication rooms, and other locations. The fixed, open frame rack allows suspending 19-inch rack equipment from Ladder Rack or Basket Tray. The rack has universal tapped holes per industry standards to accommodate typical applications. These open frame racks are ideal for high-density cabling applications which require above-the-cabinet mounting of equipment, and provide maximum access to cables and equipment. In applications where equipment expands above the cabinet, CABLERACK provides ideal management with increased equipment and cable densities.

FEATURES

- Designed to accommodate all standard 19-inch rack equipment
- Easy, single-tool assembly reduces installation time and cost
- Preassembled for fast, time-saving installation
- Securely mounts to either Cable Runway (Ladder Rack) or Basket Tray
- UL double lug ground holes provide easy adherence to local bonding and grounding codes
- Cable tie down points, sized for up to 1-inch Velcro® straps, provided in horizontal and vertical positions in multiple locations
- Parallel or perpendicular mounting to cable pathway
- Multi-point mounting provisions address various application needs

- Open design provides for maximum access to cables and equipment
- Smart packaging with hand-carrying holes allow for easy transportation

SPECIFICATIONS

- Wall section made of heavy gauge cold rolled steel welded construction
- Side supporting fingers made of composite material with black finish
- Tapped holes (12-24UNC) per EIA Universal pattern standard (1/4-5/8-5/8-1/4)

FINISH

- Pretreated steel coated with RAL 9005 black textured, low-gloss polyester powder paint
- Hardware is clear or plated black

LOAD RATING

Static load rating is 100 lbs.

ACCESSORIES

Cable Bend Radius Accessory
Blanking Panels
Grounding kits
PDUs
Shelves

BULLETIN: DOFRW

Standard Product

Catalog Number	AxBxC in./mm	Rack Units	Cable Bend Radius Accessory
E19T6U	12.44 x 20.16 x 11.50 316 x 512 x 292	6	ECMBA4

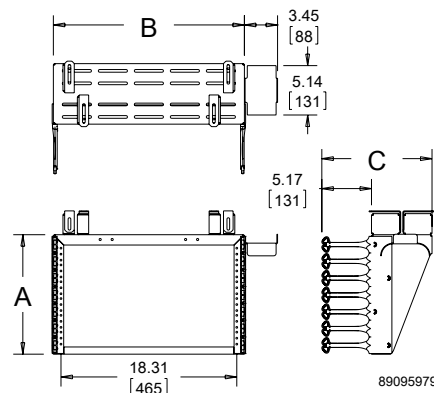

CABLERACK CABLE BEND RADIUS ACCESSORY



Cable Bend Radius Accessory complements the CABLERACK and easily attaches at multiple locations on the rack. Accessory includes four bend radius brackets and mounting hardware.

BULLETIN: DOFRW

Standard Product

Catalog Number	AxBxC in./mm	Use With
ECMBA4	2.24 x 5.16 x 3.46 57 x 131 x 88	E19T6U

CABLERACK HARDWARE KIT



Kit consists of (4) 1/4-20x1.5 carriage bolts; (12) 1/4-20x.75 carriage bolts; (16) 1/4-20 keps nuts; and installation instructions.

BULLETIN: DOFRW

Standard Products

Catalog Number	Description
ECKIT	CABLERACK hardware kit