

OPERATOR ADAPTER GEV

Installation Instructions for General Electric Types STDA Variable Depth Operating Mechanisms
(For parts list, see Page 2)

For floor-mounted enclosures with
the disconnect on the right flange

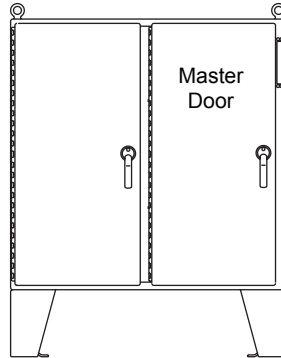

For one- through six-door free-standing enclosures
with the disconnect the the right flange

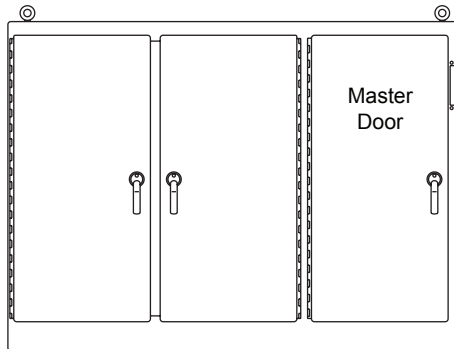

For floor-mounted enclosures with
the disconnect on the centerpost

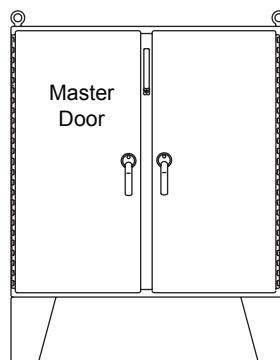

WARNING

The functions, fits and clearances of the installation described hereon are calculated from information supplied by the manufacturers of the equipment to be installed. Be certain to check the function, fits and clearances of all equipment both before and after installation to assure that it operates properly and safely and meets all applicable codes, standards and regulations.

In the event the completed installation does not function properly or fails to meet any such codes, standards or regulations, do not attempt to make alterations or operate the equipment. Report such facts immediately to:

Hoffman Customer Service
2100 Hoffman Way
Anoka, MN 55303
763.422.2211
<http://hoffman.nvent.com/contact-us>

Parts List

Operator Adapter, Catalog Number GEV, for General Electric Disconnects

Item No.	Description	Part No.	Qty.
1	ADAPTER PLATE, VARIABLE DEPTH	89112746	1
2	PLATE GASKET	89109613	1
3	SCREW, 1/4-20X1/2 PAN HEAD	99401031	4
4	SLIDE ARM	26250001	1
5	SHOULDER COLLAR	26149001	1
6	SCREW, 1/4-20X7/8, HEX HEAD	99401030	1
7	LOCKWASHER, 1/4 SPRING	99401318	1
8	WASHER, FLAT	22101003	2
9	LOCKWASHER, 1/4 INTERNAL TEETH	99401300	2
10	NUT, 1/4-20 HEX	99401406	2
11	DOOR CATCH	23101002	1
12	SCREW, 10-32X3/8 PAN HEAD	99401007	2
13	LOCKWASHER, #10 INTERNAL TEETH	99401307	2
14	NYLON WASHER	26132003	4
15	INSTALLATION INSTRUCTIONS	89114664	1

INTRODUCTION

This installation instruction is for General Electric (variable depth) mechanisms. These mechanisms are for disconnect switches and circuit breakers mounted in Hoffman wo-door, floor-mounted, enclosures with the disconnect on the right flange.

INSTALLATION STEPS

Step 1

Install operating plate (item 1) and plate gasket (item 2) on the inside of the enclosure, behind the rectangular opening provided. Gasket side with PSA should be attached to the adapter plate. Secure in place with four screws (item 3) and four nylon washers (item 14).

Step 2

Assemble the General Electric G.E. STDA operating handle to the mounting plate which was installed in the enclosure in step 1. Omit cap screw and lockwasher which fits into bottom hole of G.E. operating handle. Also omit G.E. stiffening bracket, which is not required.

Step 3

Install the slide arm (item 4) over the interlock part of the G.E. operating handle as shown. Note the the notch in the slide arm is positioned toward the door opening. Place the smaller diameter end of the shoulder collar (item 5) through the oval slot in the slide arm. Install long cap screw (item 6) with lockwasher (item 7) through shoulder collar into the bottom mounting hole of the G.E. operating handle and tighten. The slide arm should move up and down smoothly. Install G.E. interlock blade per G.E. instructions.

Step 4

Attach the bottom of the slide arm (item 4) to the offset arm of the lock release mechanism. Use two flat washer (item 8), two lockwashers (item 9), and two hex nuts (item 10). Do not tighten until parts are adjusted (see step 5B).

Step 5

The handle safety lock release mechanism is adjustable.

(A) Check the adjustment of the factory installed roller bracket. The door latch should hit against the latch stop portion of the roller bracket when the door is closed and latched. Adjust up or down if necessary. The attached mechanism will then provide the necessary up-down motion required to operate the release mechanism in the G.E. operating handle.

(B) Adjust the length of the slide arm assembly. With proper adjustment of the slide arm, the safety lock (in G.E. operating handle) should release just before the master door is fully latched. Lengthen slide arm if safety lock releases too soon. Shorten slide arm if safety lock releases too late.

Step 6

Attach the door catch (item 11), provided by Hoffman, to the tapped spacer on the door using the bottom set of mounting holes. Use two screws (item 12) and lockwashers (item 13). The door catch prevents the door from being opened when the G.E. operating handle is in the "ON" position.

Step 7

Drill and tap holes in panel per General Electric instructions. See General Electric instructions for locating holes for fuse blocks for 200 AMP switches.

Step 8

Install panel in enclosure.

Step 9

Mount disconnect switch or circuit breaker and operating mechanism on panel using General Electric instructions and parts. Attach G.E. handle return spring between drive link on G.E. operating handle and hole provided in Hoffman adapter plate as shown.

For Floor-Mounted, Two-Door Enclosures with Disconnect on Right Flange

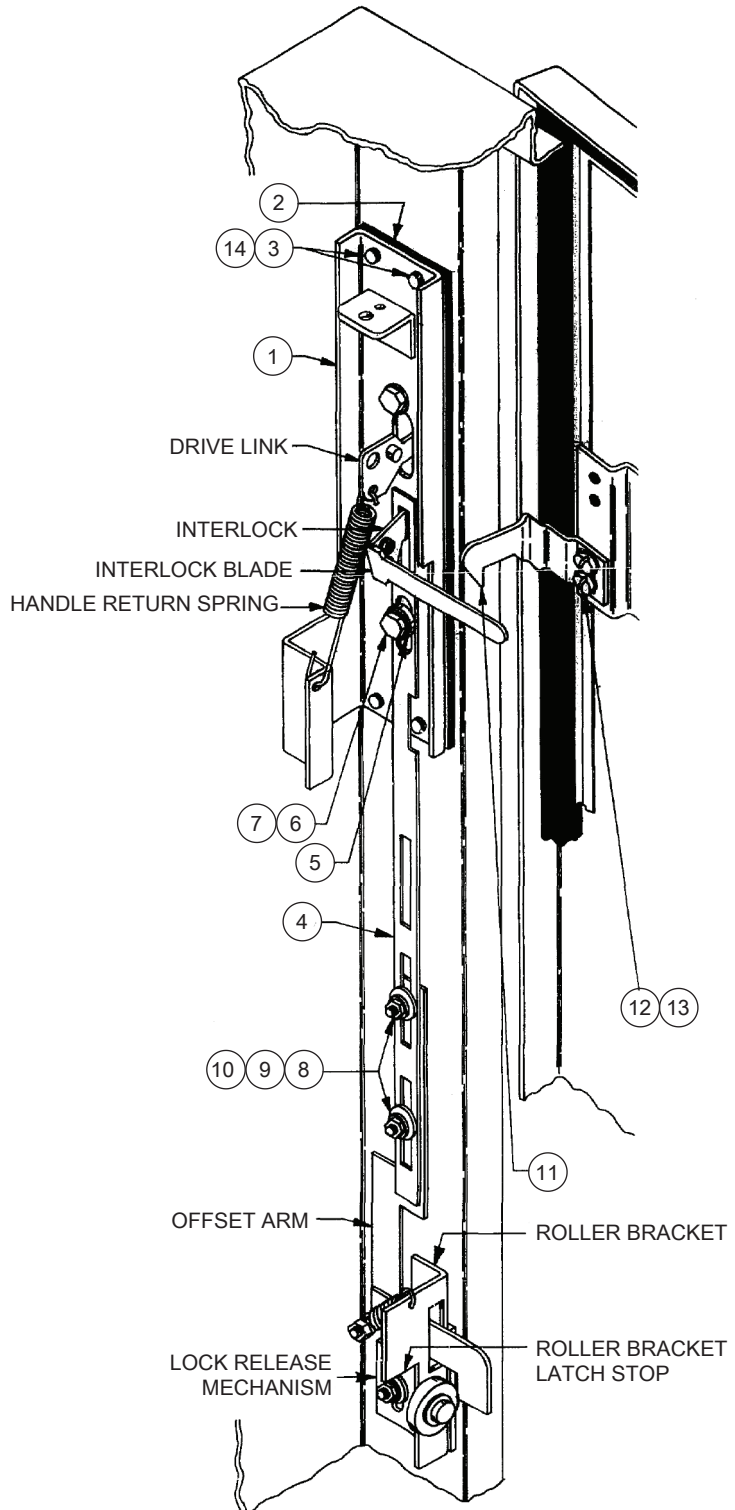

INTRODUCTION

This installation instruction is for General Electric (variable depth) mechanisms. These mechanisms are for disconnect switches and circuit breakers mounted in Hoffman one through six door, free-standing enclosures with the disconnect on the right flange.

INSTALLATION STEPS

Step 1

Install adapter plate (item 1) and plate gasket (item 2) on the inside of the enclosure, behind the rectangular opening provided. Gasket side with PSA should be attached to adapter plate. Secure in place with four screws (item 3) and four nylon washers (item 14).

Step 2

Assemble the G.E. STDA operating handle to the mounting plate which was installed the enclosure in step 1. Omit cap screw and lockwasher which fits into bottom hole of G.E. operating handle. Also omit G.E. stiffening bracket which is not required.

Step 3

Install the slide arm (item 4) over the interlock part of the G.E. operating handle as shown. Note that the notch in the slide arm is positioned toward the door opening. Place the smaller diameter end of the shoulder collar (item 5) through the oval slot in the slide arm. Install long cap screw (item 6) with lockwasher (item 7) through shoulder collar into the bottom mounting hole of the G.E. operating handle and tighten. The slide arm should move up and down smoothly. Install G.E. interlock blade per G.E. instructions

Step 4

Attach the bottom of the slide arm (item 4) to the offset arm of the lock release mechanism. Use two flat washers (item 8), two lockwashers (item 9), and two hex nuts (item 10). Do not tighten until parts are adjusted (see step 5B)

Step 5

The handle safety lock release mechanism is adjustable in two places.

A) Check the adjustment of the factory installed roller bracket. The door latch should hit against the latch stop portion of the roller bracket when the door is closed and latched. Adjust up or down if necessary. The attached mechanism will then provide the necessary up-down motion required to operate the release mechanism in the G.E. operating handle.

B) Adjust the length of the slide arm assembly. With proper adjustment of the slide arm, the safety lock (in G.E. operating handle) should release just before the master door is fully latched. Lengthen slide arm if safety lock releases too soon. Shorten slide arm if safety lock releases too late.

Step 6

Attach the door catch (item 11) provided by Hoffman to the tapped spacer on the door using the bottom set of mounting holes. Use two screws (item 12) and lockwashers (item 13). The door catch prevents the door from being opened when the G.E. operating handle is in the "ON" position.

Step 7

Drill and tap holes in panel per General Electric instructions. See General Electric instructions for locating holes for fuse blocks for 200 AMP. switches.

Step 8

Install panel in enclosure.

Step 9

Mount disconnect switch or circuit breaker and operating mechanism on panel using General Electric instructions and parts. Install and adjust G.E. drive rod per G.E. instructions. Attach G.E. handle return spring between drive link on G.E. operating handle and hole provided in Hoffman adapter plate as shown.

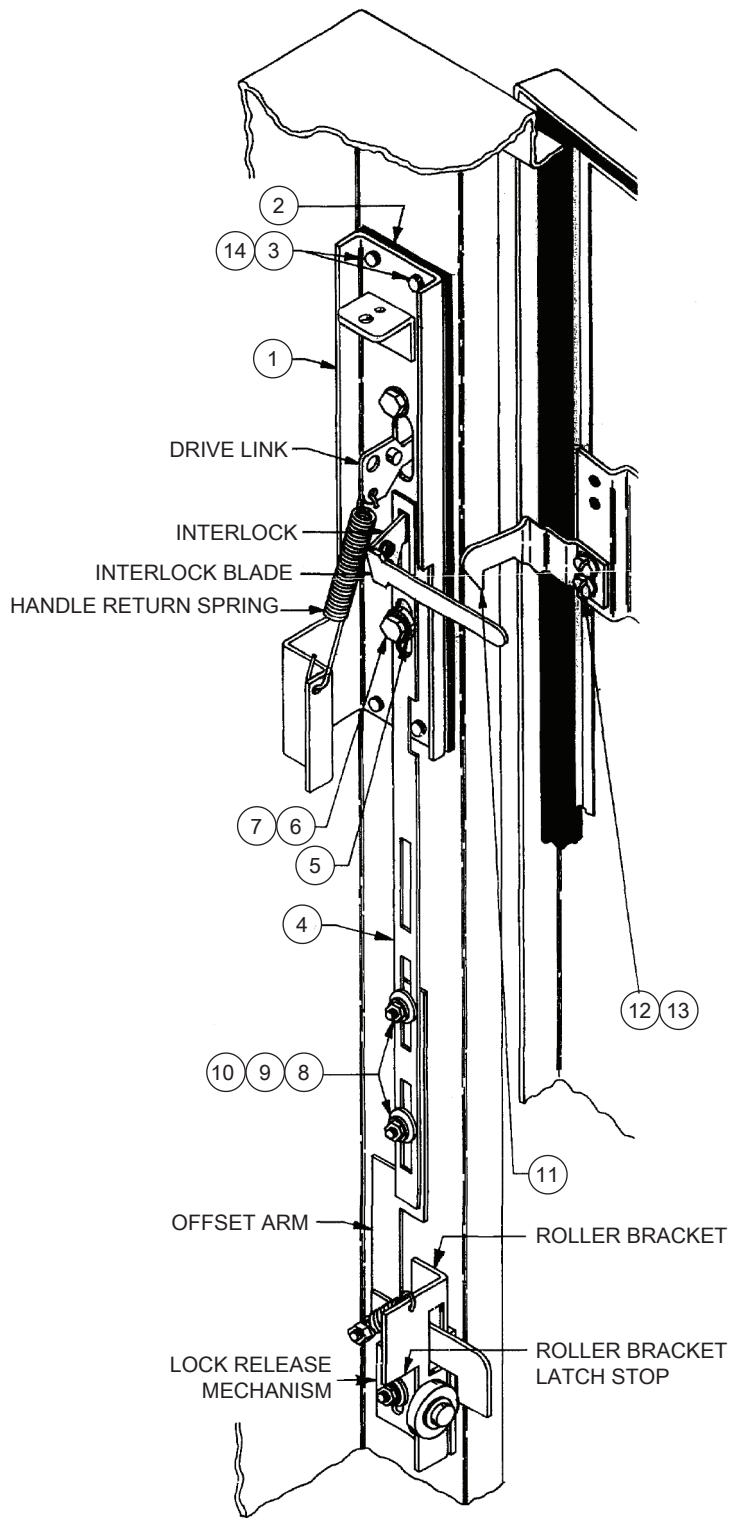

INTRODUCTION

This installation instruction is for General Electric variable depth) mechanisms. These mechanisms are for disconnect switches and circuit breakers mounted in Hoffman two door, floor-mounted enclosures with the disconnect on the centerpost.

INSTALLATION STEPS

Step 1

Install adapter plate (item 1) and plate gasket (item 2) on the inside of the enclosure, behind the rectangular opening provided in the centerpost. Gasket side with PSA should be attached to the adapter plate. Secure in place with four screws (item 3), and four nylon washers (item 14).

Step 2

Assemble the G.E. type STDA operating handle to the mounting plate which was installed in the enclosure in step 1. Omit cap screw and lockwasher which fits into bottom hole of G.E. operating handle. Also omit G.E. stiffening bracket which is not required.

Step 3

Cut 2 1/2 inches off bottom end of slide arm (item 4). (bottom end of slide arm has rectangular holes only)

Step 4

Install the slide arm (item 4) over the interlock part of the G.E. operating handle as shown. Note that the notch in the slide arm is positioned toward the door opening. Place the smaller diameter end of the shoulder collar (item 5) through the oval slot in the slide arm. Install long cap screw (item 6) with lockwasher (item 7) through shoulder collar into the bottom mounting hole of the G.E. operating handle and tighten. The slide arm should move up and down smoothly. Install G.E. interlock blade per G.E. instructions.

Step 5

Attach the bottom of the slide arm (item 4) to the offset arm as shown. Use two flat washers (item 8), two lockwashers (item 9), and two hex nuts (item 10). Do not tighten until parts are adjusted.

Step 6

Adjust the length of the slide arm assembly. With proper adjustment of the slide arm, the safety lock (in G.E. operating handle) should release just before the master door is fully latched. Lengthen slide arm if safety lock releases too soon. Shorten slide arm if safety lock releases too late.

Step 7

Attach the door catch (item 11) provided by Hoffman to the tapped space on the door using the bottom set of mounting holes. Use two screws (item 12) and two lockwashers (item 13). The door catch prevents the door from being opened when the G.E. operating handle is in the "ON" position.

Step 8

Drill and tap holes in panel per General Electric instructions. See General Electric instructions for locating holes for fuse blocks for 200 AMP. switches.

Step 9

Install panel on collar studs in enclosure.

Step 10

Mount disconnect switch or circuit breaker and operating mechanism on panel using General Electric instructions and parts. Install and adjust G.E. drive rod per G.E. instructions. Attach G.E. handle return spring between drive link on G.E. operating handle and hole provided in Hoffman adapter plate as shown.

*** NOTE: An optional General Electric flange stiffener kit (catalog number TDSR) is recommended when General Electric type STDA devices are installed in 72.12 inch high enclosures with operating handle mounted on centerpost. Use with TDOM1,2,3 operating mechanisms.**

