

OPERATOR ADAPTER ECHV

Installation Instructions for Eaton Cutler-Hammer C361 and C371 Variable Depth Operating Mechanisms
(For parts list, see Page 2)

For floor-mounted enclosures with
the disconnect on the right flange

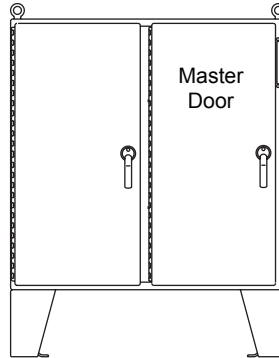

For one- through six-door free-standing enclosures
with the disconnect the the right flange

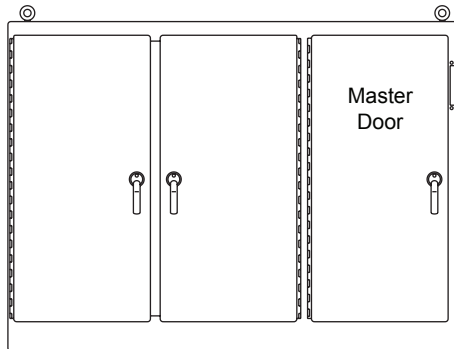

For floor-mounted enclosures with
the disconnect on the centerpost

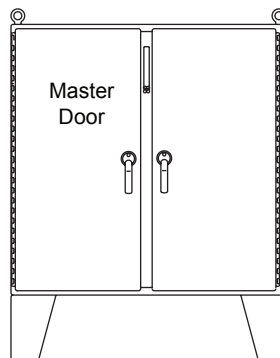

WARNING

The functions, fits and clearances of the installation described hereon are calculated from information supplied by the manufacturers of the equipment to be installed. Be certain to check the function, fits and clearances of all equipment both before and after installation to assure that it operates properly and safely and meets all applicable codes, standards and regulations.

In the event the completed installation does not function properly or fails to meet any such codes, standards or regulations, do not attempt to make alterations or operate the equipment. Report such facts immediately to:

Hoffman Customer Service
2100 Hoffman Way
Anoka, MN 55303
763.422.2211
<http://hoffman.nvent.com/contact-us>

Parts List

Operator Adapter, Catalog Number ECHV, for Eaton Cutler-Hammer C361, C371 Disconnects

Item No.	Description	Part No.	Qty.
1	MOUNTING PLATE, C-H C361 AND C371	26385001	1
2	GASKET, PLATE	89109613	1
3	SCREW, 1/4-20X1/2 PAN HEAD	99401031	4
4	SLIDE ARM	26250001	1
5	SHOULDER COLLAR	26149001	1
6	SCREW, 1/4-20X7/8 HEX HEAD	99401030	1
7	LOCKWASHER, 1/4 SPRING	99401318	1
8	WASHER, FLAT	22101003	2
9	LOCKWASHER, 1/4 INTERNAL TEETH	99401300	2
10	NUT, 1/4-20 HEX	99401406	2
11	DOOR CATCH	23101002	1
12	SCREW, 10-32X3/8 PAN HEAD	99401007	2
13	LOCKWASHER, #10 INTERNAL TEETH	99401307	2
14	NYLON WASHER	26132003	4
15	INSTALLATION INSTRUCTIONS	89114655	1

INTRODUCTION

This installation instruction is for Eaton Cutler-Hammer C361, C371 (variable depth) mechanisms. These mechanisms are for disconnect switches and circuit breakers mounted in Hoffman two-door floor-mounted, Bulletin A21 enclosures with the disconnect on the right flange.

INSTALLATION STEPS

Step 1

Install mounting plate (item 1) and plate gasket (item 2) on the inside of the enclosure, behind the rectangular opening provided. Gasket side with PSA should be attached to the adapter plate. Secure in place with four screws (item 3) and four nylon washers (item 14).

Step 2

Discard the Cutler-Hammer spring bracket which is normally installed inside the enclosure flange, behind the C-H handle mechanism.

Step 3

Assemble the Cutler-Hammer handle mechanism to the mounting plate which was installed in the enclosure in step 1. Omit cap screw and lockwasher which fits into bottom hole of the handle mechanism.

Step 4

Install the slide arm (item 4) over the defeater part of the handle assembly (on C-H handle mechanism) with notch toward door opening, as shown. Place the smaller diameter end of the shoulder collar (item 5) through the oval slot in the slide arm. Install long cap screw (item 6) with lockwasher (item 7) through shoulder collar into the bottom mounting hole of the C-H handle mechanism and tighten. The slide arm and defeater should move up and down smoothly. Install door hasp (C-H part) per Cutler-Hammer instructions.

Step 5

Attach the bottom of the slide arm (item 4) to the offset arm of the lock release mechanism. Use two flat washers (item 8), two lockwashers (item 9), and two hex nuts (item 10). Do not tighten until parts are adjusted (see step 6B)

Step 6

The handle safety lock release mechanism is adjustable in two places.

(A) Check the adjustment of the factory installed roller bracket. The door latch should hit against the latch stop portion of the roller bracket when the door is closed and latched. Adjust up or down if necessary. The attached mechanism will then provide the necessary up-down motion required to operate the release mechanism in the C-H handle mechanism.

(B) Adjust the length of the slide arm assembly. With proper adjustment of the slide arm, the safety lock (on Cutler-Hammer handle mechanism) should release just before the master door is fully latched. Lengthen slide arm if safety lock releases too soon. Shorten slide arm if safety lock releases too late.

Step 7

Attach the door catch (item 11), provided by Hoffman, to the tapped spacer on the door using the bottom set of mounting holes. Use two screws (item 12) and lockwashers (item 13). The door catch prevents the door from being opened when the handle mechanism is in the "ON" position.

Step 8

Drill and tap holes in panel per Eaton Cutler-Hammer instructions. See Eaton Cutler-Hammer instructions for locating extra holes for fuse clips.

Step 9

Mount switch or circuit breaker using Eaton Cutler-Hammer instructions and parts. C-H connecting rod must be cut off per Eaton Cutler-Hammer instructions.

For Floor-Mounted, Two-Door Enclosures with Disconnect on Right Flange

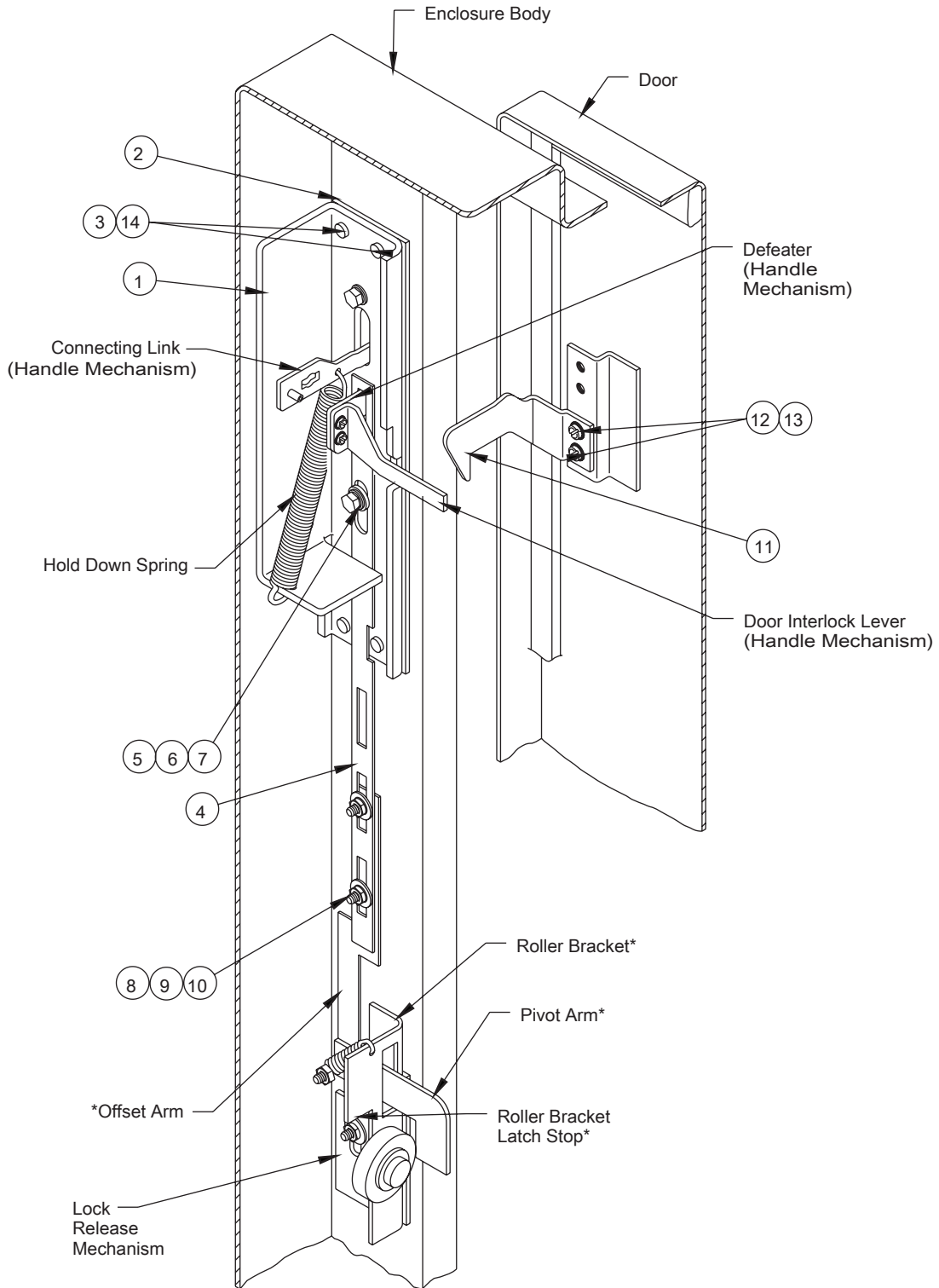

* PARTS OF LOCK RELEASE MECHANISM

INTRODUCTION

This installation instruction is for Eaton Cutler-Hammer C361, C371 (variable depth) mechanisms. These mechanisms are for disconnect switches and circuit breakers mounted in Hoffman one through six door, free-standing Bulletin A28M1, A34Y and A4L3D enclosures with the disconnect on the right flange.

INSTALLATION STEPS

Step 1

Install Mounting plate (item 1) and plate gasket (item 2) on the inside of the enclosure, behind the rectangular opening provided. Gasket side with PSA should be attached to the adapter plate. Secure in place with four screws (item 3) and four nylon washers (item 14).

Step 2

Discard the Cutler-Hammer spring bracket which is normally installed inside the enclosure flange behind the C-H handle mechanism.

Step 3

Assemble the Cutler-Hammer handle mechanism to the mounting plate which was installed in the enclosure in step 1. Omit cap screw and lockwasher which fits into bottom hole of the handle mechanism.

Step 4

Install the slide arm (item 4) over the defeater part of the handle assembly (on C-H handle mechanism) with notch toward door opening, as shown. Place the smaller diameter end of the shoulder collar (item 5) through the oval slot in the slide arm. Install long cap screw (item 6) with lockwasher (item 7) through shoulder collar into the bottom mounting hole of the C-H handle mechanism and tighten. The slide arm and defeater should move up and down smoothly. Install door hasp (C-H part) per Cutler-Hammer instructions.

Step 5

Attach the bottom of the slide arm (item 4) to the offset arm of the lock release mechanism. Use two flat washers (item 8), two lockwashers (item 9), and two hex nuts (item 10). Do not tighten until parts are adjusted. (see step 6B)

Step 6

The handle safety lock release mechanism is adjustable in two places.

(A) Check the adjustment of the factory installed roller bracket. The door latch should hit against the latch stop portion of the roller bracket when the door is closed and latched. Adjust up or down if necessary. The attached mechanism will then provide the necessary up-down motion required to operate the release mechanism.

(B) Adjust the length of the slide arm assembly. With proper adjustment of the slide arm, the safety lock (on Cutler-Hammer handle mechanism) should release just before the master door is fully latched. Lengthen slide arm if safety lock releases too soon. Shorten slide arm if safety lock releases too late.

Step 7

Attach the door catch (item 11), provided by Hoffman, to the tapped spacer on the door using the bottom set of mounting holes. Use two screws (item 12) and lockwashers (item 13). The door catch prevents the door from being opened when the handle mechanism is in the "ON" position.

Step 8

Drill and tap holes in panel per Eaton Cutler-Hammer instructions. See Eaton Cutler-Hammer instructions for locating extra holes for fuse clips.

Step 9

Mount switch or circuit breaker using Eaton Cutler-Hammer instructions and parts. Eaton Cutler-Hammer connecting rod assembly must be cut off per Cutler-Hammer instructions.

For One Through Six Door Free-Standing Enclosures with Disconnect on Right Flange

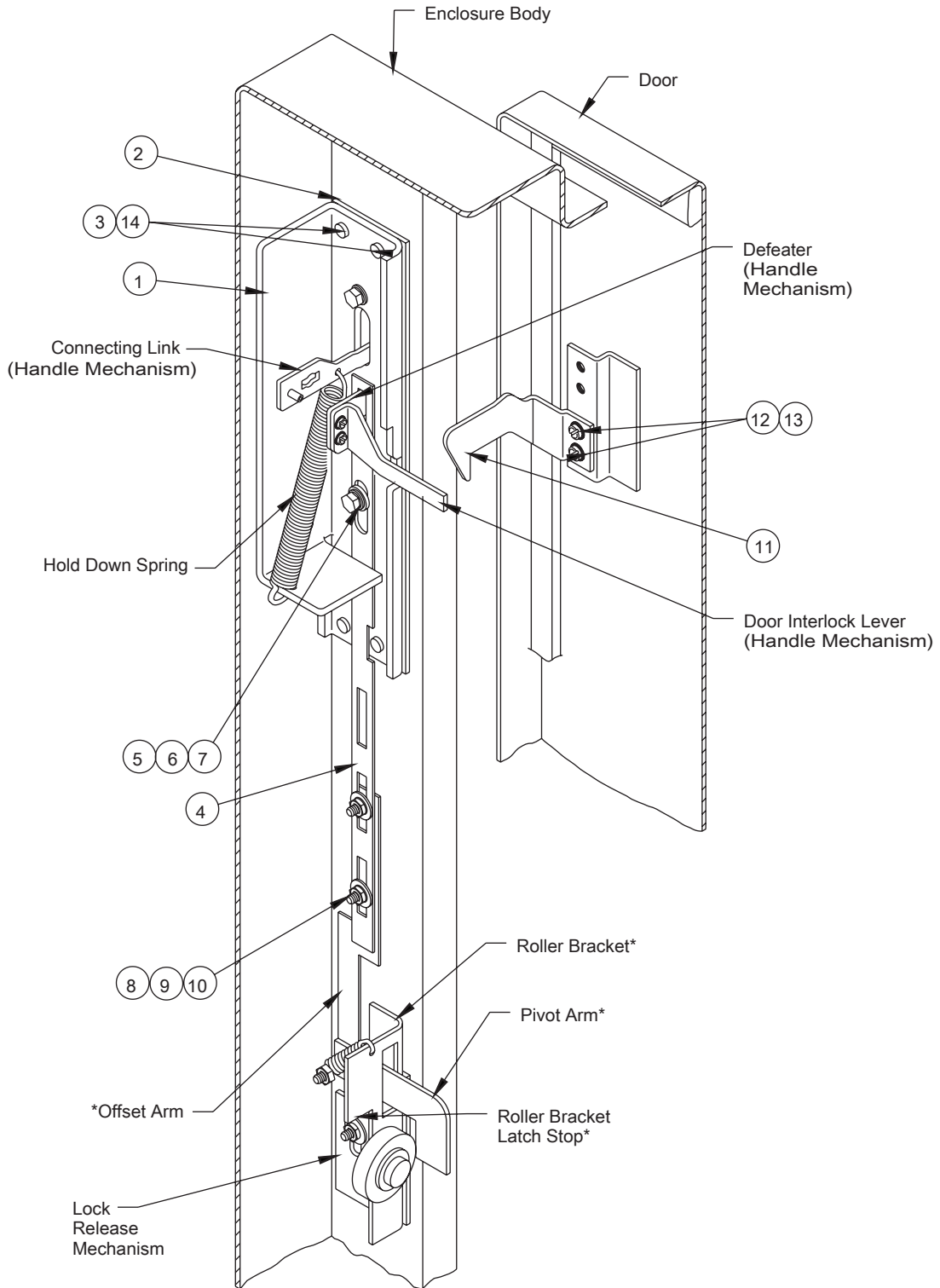

* PARTS OF LOCK RELEASE MECHANISM

INTRODUCTION

This installation instruction is for Eaton Cutler-Hammer C361, C371 (variable depth) mechanisms. These mechanisms are for disconnect switches and circuit breakers mounted in Hoffman two door, floor-mounted Bulletin A21 enclosures with the disconnect on the centerpost.

INSTALLATION STEPS

Step 1

Install Mounting plate (item 1) and plate gasket (item 2) on the inside of the enclosure, behind the rectangular opening provided in the centerpost. Gasket side with PSA should be attached to the adapter plate. Secure in place with four screws (item 3) and four nylon washers (item 14).

Step 2

Discard the Cutler-Hammer spring bracket which is normally installed inside the enclosure flange behind the C-H handle mechanism.

Step 3

Assemble the Cutler-Hammer handle mechanism to the mounting plate which was installed in the enclosure in step 1. Omit cap screw and lockwasher which fits into bottom hole of operating handle.

Step 4

Cut 2 1/2" off bottom end of slide arm (item 4). (bottom end has rectangular holes only) Step 5 - Install the slide arm (item 4) over the defeater part of the handle assembly (on C-H handle mechanism) with notch toward door opening, as shown. Place the smaller diameter end of the shoulder collar (item 5) through the oval slot in the slide arm. Install long cap screw (item 6) with lockwasher (item 7) through shoulder collar into the bottom mounting hole of the C-H handle mechanism and tighten. The slide arm and defeater should move up and down smoothly. Install door hasp (C-H part) per Cutler-Hammer instructions.

Step 6

Attach the bottom of the slide arm (item 4) to the offset arm of the lock release mechanism. Use two flat washers (item 8), two lockwashers (item 9), and two hex nuts (item 10). Do not tighten until parts are adjusted.

Step 7

Adjust the length of the slide arm assembly. With proper adjustment of the slide arm, the safety lock (on Cutler-Hammer handle mechanism) should release just before the master door is fully latched. Lengthen slide arm if safety lock releases too soon. Shorten slide arm if safety lock releases too late.

Step 8

Attach the door catch (item 11), provided by Hoffman, to the tapped spacer on the door using the bottom set of mounting holes. Use two screws (item 12) and lockwashers (item 13). The door catch prevents the door from being opened when the handle mechanism is in the "ON" position.

Step 9

Drill and tap holes in panel per Eaton Cutler-Hammer instructions. See Eaton Cutler-Hammer instructions for locating extra holes for fuse clips.

Step 10

Mount switch or circuit breaker using Eaton Cutler-Hammer instructions and parts. Eaton Cutler-Hammer connecting rod assembly must be cut off per Cutler-Hammer instructions.

*** NOTE: Optional channel support kit, Eaton Cutler-Hammer C371-CS6, is recommended when installing 600 AMP circuit breakers in 72 1/8" high enclosures.**

For Floor-Mounted, Two Door Enclosures with Disconnect on Centerpost

