

INSTALL GUIDE

ProLine Aisle Containment Rack Top Baffle

Part Number

UACTB6A	UACTB75A
UACTB6V	UACTB75V
UACTB7A	UACTB8A
UACTB7V	UACTB8V



Each Carton Contains:

- (2) Clear Plastic Panel Assemblies
- (4) Magnet Tail Assemblies
- (2) Alignment Clips

Tools & Hardware Required

The Rack Top Baffle Assembly attaches to the tops of IT rack cabinets using strong rare earth magnets. Use extreme caution when handling the powerful magnets. Make sure to keep fingers clear of the contact area between the magnets and the metal mounting surface.

For proper mounting, the Rack Top Baffle magnets must make direct contact with a steel or other ferrous metal surface, e.g. rack top panel, rack frame, etc. Any obstruction that prevents the magnets from making direct metal contact will reduce the holding force of the magnets and may cause the Rack Top Baffle to fall.

Installation will likely require the use of a ladder or moveable stairs, caution should be exercised when climbing up and down ladders/stairs. When standing on the ladder/stairs, be careful of overhead lighting or cabling.

Each Carton Contains:

1. Determine the best attachment position for the Magnet Tails
The tail assembly can be mounted in a number of different positions. The outer most positions often work best on many cabinets. Before attaching the tails to the extrusion base, make sure to inspect the top surface of the cabinet the Rack Top Baffle Assembly will be mounted to. Many cabinets have cable cutouts, or other potential interference issues that must be avoided. The greatest attachment force results from attaching to the frame and thick metal components.
2. Attach the Tail Assemblies to the Extrusion
The magnet comes preassembled to the magnet

tail with a thumbscrew. The magnet position is adjustable on the tail, but movement of the magnet is rarely needed.

- a. With the most optimum mounting location identified, remove the thumbscrew from the tail assembly, which is NOT attached to the magnet.
- b. Position the tail assembly beneath the desired hole on the extrusion base flange. Insert the thumb screw thru the required hole on the extrusion base and thread into the receiving threaded hole on the tail assembly. Tighten by hand. Repeat for the 2nd tail assembly.

INSTALL GUIDE

3. Position the Rack Top Baffle Assembly on top of the rack
 - a. To simplify full front to back and side to side adjustability, the key is to keep the magnets elevated, free from making any contact, until proper positioning has been established.
 - b. Starting at the end of the aisle, rest the front contact edge of the Rack Top Baffle Assembly extrusion base as close to the front of the cabinet frame (not the door) as allowable.
 - c. Maintain the Rack Top Baffle Assembly with the magnet tails in the air, and center the Rack Top Baffle Assembly left to right.
 - d. When proper positioning has been established, rotate the baffle up until the magnets make contact with the sheetmetal with an audible 'click'.

Note: To reposition the baffle, grab the middle top of the clear panel and push up or back in a continuous manner, such that the action lifts the front edge of the extrusion base off the cabinet and peels off the magnets from contact.

Important: Do not attempt remove Rack Top Baffle Assembly by pulling down or forward.

4. Continue placing the Rack Top Baffle Assembly on top of each rack in the aisle
 - a. Continue to populate the aisle by placing the Rack Top Baffle Assembly on top of each rack in the row. It is best to install both sides of the aisle, as you move down the rows.
 - b. Keep the gap between the plastic panels at a

minimum and align the Rack Top Baffle Assemblies evenly across the top of the racks.

- c. An optional alignment clip is provided to address any baffle misalignment.

Use of the clips will help straighten out the alignment of the baffles. Simply slide the clip on to the top edge, across the gap of two adjacent panels.

Instructions for Cleaning

- a. To clean clear plastic panels, mix warm water with a small amount of liquid household detergent.
- b. Using a micro fiber towel, lightly apply mixture to the clear plastic. It is not recommended to use abrasive cleaning items (i.e. scratch pads), as these items have the potential to damage the product.
- c. Wipe dry with a clean microfiber towel.

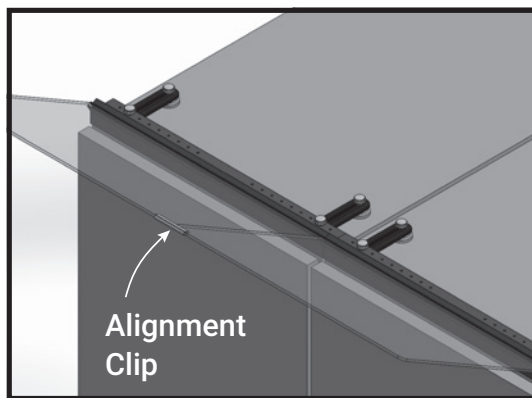

30° Angular Configuration

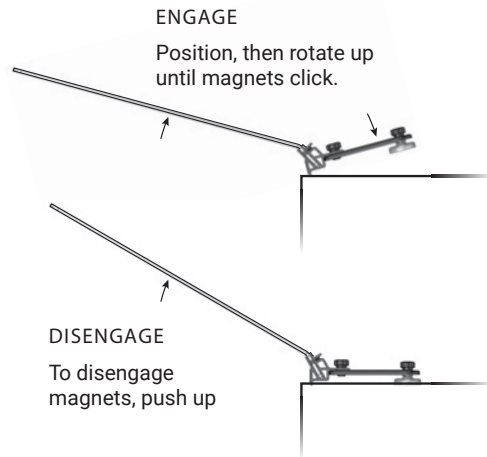

90° Vertical Configuration

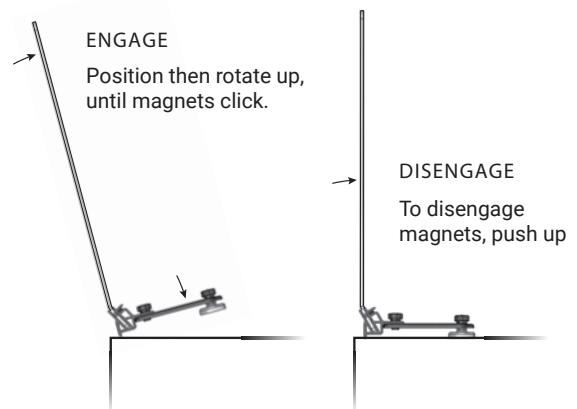

LIMITED WARRANTY

nVent (the Company) warrants to the original purchaser that products delivered hereunder will be free of defects in materials and workmanship for a period of twelve (12) months from the date of purchase (the "Warranty Period").

The Company shall, at its option, within the Warranty Period, either repair or replace free of charge, any product or part thereof found, upon the Company's inspection, to be defective in materials and workmanship, and will return the repaired or replaced product to the purchaser at Company's expense.

For warranty service and shipping instructions, contact the Company at the telephone number shown below. If the product is under warranty and the defect appears to be covered by this Limited Warranty, the Company will issue to the purchaser a Notice of Authorization For Warranty Return. Products returned to the Company for warranty service must be accompanied by a statement of defect, the Notice of Authorization for Warranty Return provided by the Company, and proof of purchase.

This Limited Warranty is conditioned on the following:

1. The **Company** must be notified within 12 months of purchase and have been given the opportunity of inspection by return of any alleged defective product free and clear of all liens and encumbrances to the **Company** or its manufacturer; and
2. The product must not have been abused, misused, or improperly maintained, and/or non-Upsite authorized repair performed during such period; and
3. Such defect has not been caused by corrosion or exposure to other than ordinary wear and tear; and
4. The installation and use of the product has been in accordance with the manufacturer's instructions and not been modified or customized to include but not limited to cut, resized, burned, glued, bent, re-shaped, disassembled, attachments added to, improperly installed or used in a manner other than intended.

The company makes no other express or implied warranty or representation of any kind whatsoever including any warranty of merchantability or fitness for a particular purpose and all such other warranties are hereby included.

The **Company's** maximum liability hereunder is limited to the purchase price of the product. In no event shall the **Company** be liable for any consequential, indirect, incidental, or special damages of any nature arising from the sale or use of the product, whether based in contract, tort, strict liability, or otherwise.

Note: Some jurisdictions do not allow limitations on incidental or consequential damages or how long an implied warranty lasts, so that the above limitations may not fully apply. This warranty gives specific legal rights and you may also have other rights which may vary from jurisdiction to jurisdiction.

For complete warranty and repair information Call 763-422-2661 or visit nvent.com/dns

