

Sequestr

External Disconnect Enclosure
For Variable Depth or Cable Operated Devices



Table of Contents

Sequestr Hardware.....	4
Preparing for Sequestr Installation	5
Removing Old Hardware and Preparing the Control Enclosure.....	5
Preparing the Control Enclosure.....	5
Sequestr Enclosure Mounting Instructions	6
Installing the Circuit Breaker/Disconnect Switch and Associated Hardware.....	7
Operating Handle Installation	7
Sequestr Defeater Arm and Cover Plate Installation.....	8
Device Operating Handle Installation	9
Defeater Slide Arm Installation.....	10
Install Control Enclosure Door Hook.....	11
Interlock Installation.....	12
Labeling.....	13
Powering Up the System.....	13
Accessing the Enclosures.....	13
Opening the Control Enclosure Door with Power "ON"	13
Opening the Sequestr Enclosure Door with Power "OFF"	13
Sequestr Enclosure Grounding	14
Sequestr Panel Installation / Grounding	14
Hardware Kits	15
Repainting Instructions	15
Drill Patterns for 34-Inch Tall Sequestr Models.....	16
Cutout Template Dimensions for 34-Inch Tall Sequestr Models.....	21

Note: These instructions are for assembling the following Sequestr external disconnect enclosure accessory to an existing disconnect enclosure.

WARNING

The functions, fits, and clearances of the installation described herein are calculated from information supplied by the manufacturers of the equipment to be installed. Be certain to check the function, fits, and clearances of all equipment both before and after installation to assure that it operates properly and safely and meets all applicable codes, standards, and regulations.

In the event the completed installation does not function properly or fails to meet any such codes, standards, or regulations, do not attempt to make alterations or operate the equipment. Report such facts immediately to:

nVent HOFFMAN Customer Service
2100 Hoffman Way
Anoka, MN 55303
763 422 2211
<http://hoffman.nvent.com/contact-us>

To avoid personal injury and/or product damage, DO NOT attempt the installation alone. The installation of the Sequestr enclosure to the control enclosure requires two people.

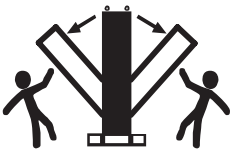

Control Enclosure is TOP-HEAVY









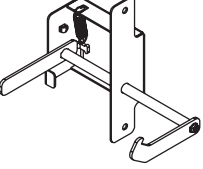
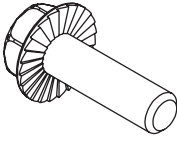

- Stabilize the control enclosure before mounting the Sequestr external disconnect enclosure to it.
- Follow guidelines in "Large Enclosure Handling Manual" supplied with the control enclosure.

To get additional copies of the "Large Enclosure Handling Manual", call 1-800-355-3560.

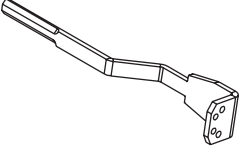
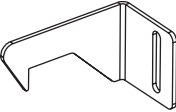
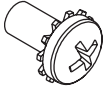
Notice:

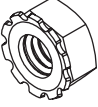
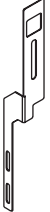
To maintain the environmental rating of this enclosure, install in any opening, only listed or recognized disconnect devices, hole seals, and/or conduit hubs that have the same environmental rating as the enclosure. Install in compliance with the installation instructions of the device.

Sequestr Hardware

<p>1</p>  <p>(1x)</p>	<p>2</p> <p>M6X20</p>  <p>TORQUE: 50 LBF/IN</p> <p>(11x)</p>	<p>3</p>  <p>(1x)</p>
<p>4</p>  <p>(2x)</p>	<p>5</p>  <p>(2x)</p>	<p>6</p>  <p>(1x)</p>
<p>7</p>  <p>(1x)</p>	<p>8</p> <p>10-32 X .38</p>  <p>TORQUE: 22 LBF/IN</p> <p>(2x)</p>	<p>9</p>  <p>(2x)</p>
<p>10</p>  <p>(2x)</p>	<p>11</p> <p>.250-20</p>  <p>TORQUE: 36 LBF/IN</p> <p>(2x)</p>	<p>12</p>  <p>(1x)</p>
<p>13</p>  <p>(1x)</p>	<p>14</p>  <p>(1x)</p>	<p>15</p>  <p>(1x)</p>

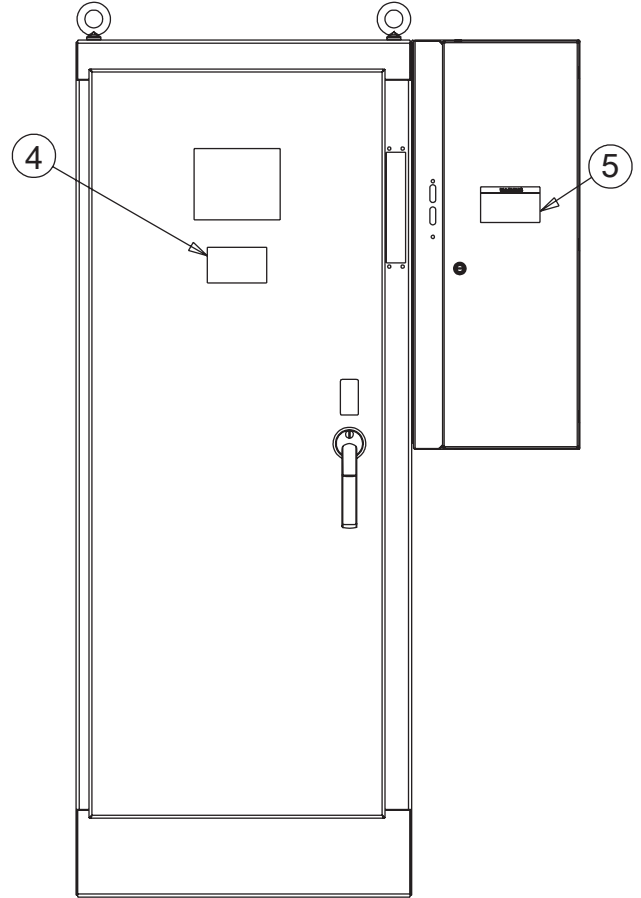

Notes:

Extra warning labels (Items 4 and 5) are included, and should be applied after the enclosure is painted or the original label is destroyed. Customers should contact nVent HOFFMAN for any additional warning labels in the event they cannot find the extra labels or need more.

Allen-Bradley's 1494F-M1 and Square D's 9422A1 operating handles are shown in these instructions.

Grounding hardware is listed in the grounding section of these instructions.

Preparing for Sequestr Installation

NOTE: The instructions on this page are for preparing to mount a Sequestr enclosure to an existing disconnect control enclosure.

Powering Down the System

1. Turn off the local disconnect installed in the control enclosure using the appropriate right or left hand rule.
2. Turn off all power to the enclosure. It could possibly be the disconnect on the bus bar.
3. Put on the correct level of Personal Protective Equipment (PPE).
4. Open the control enclosure.
5. Test for power on the incoming side of the disconnect using a volt meter.

Removing Old Hardware and Preparing the Control Enclosure

For installations with both the device and the handle installed in the Sequestr enclosure (cable or variable depth):

1. Remove the breaker/switch device, control handle and related hardware from the control enclosure.
2. Remove the incoming power feed and seal the existing hole using an nVent HOFFMAN hole seal (order separately).
3. Cover and protect all components installed in the control enclosure. Remove covers before powering up the system; see page 11.

For installations with the device installed in the Sequestr enclosure and the handle installed in the control enclosure as a cable operated device:

1. Remove the breaker/ switch device and related hardware from the control enclosure.
2. Remove the incoming power feed and seal the existing hole using a HOFFMAN hole seal (order separately).
3. Cover and protect all components installed in the control enclosure.

Preparing the Control Enclosure

1. Referring to the Drill Patterns for 34-Inch Tall Sequestr Models section on pages 14 - 18 of these instructions, mark the Sequestr mounting hole locations on the control enclosure from the appropriate layout pattern for the enclosure bulletin and size.

* 1:1 scale downloadable templates are available at nVent/Hoffman.com.

If using the downloadable template, or making one from the dimensions given, it is suggested that the holes be resized to allow drill bushings to be installed.

2. Drill, cut and deburr the holes in the side of the control enclosure.
3. When installing a cable operated or variable depth device and control handle in the Sequestr enclosure, install a separately ordered nVent HOFFMAN blank adapter plate over the universal disconnect cutout of the control enclosure.

Sequestr Enclosure Mounting Instructions

1. Remove the subpanel from the Sequestr enclosure for installation of the disconnect switch or circuit breaker. **Save the hex nuts for reinstallation.**
2. Locate, drill and deburr a hole for the power line entrance into the Sequestr enclosure.
3. Install the gasket per Figure 1A, engaging the dove tail joints, and trim off any excess. Refer to Figure 1B for the correct enclosure depth configuration.
4. Referring to Figure 1C, raise and support the Sequestr enclosure to the side of the control enclosure. Alignment can be aided by inserting guide pins through one or two holes from the inside of the control enclosure.
5. Install eight (8) M6x20mm washer head cap screws (Item 2) from inside the control enclosure at the locations shown and tighten.
6. Ground washer (Item 15) may be installed on any of the mounting screws..

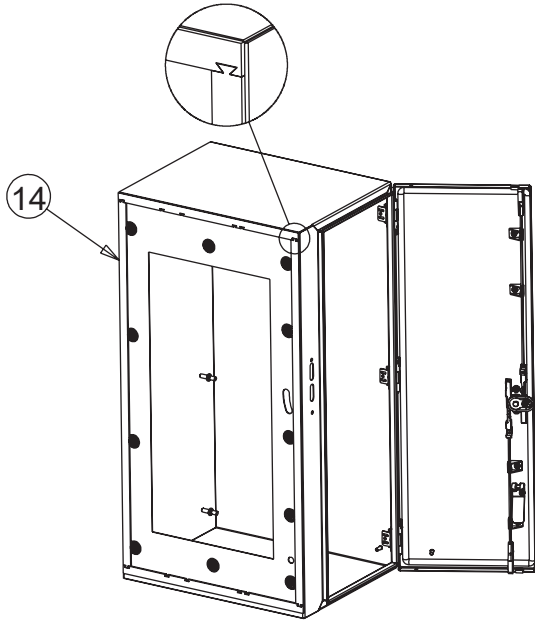

Figure 1A

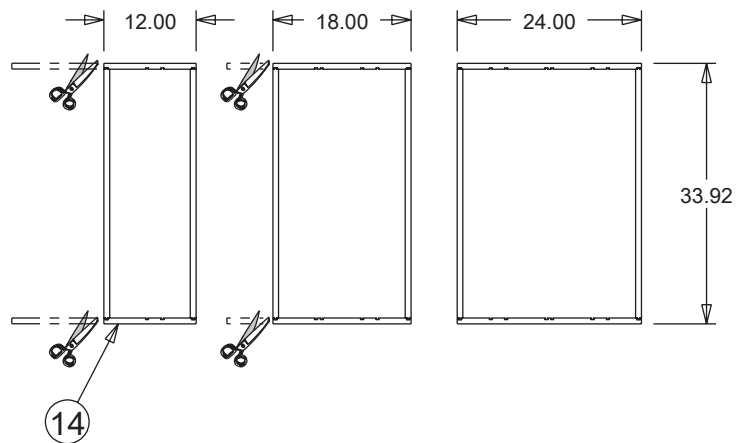

Figure 1B

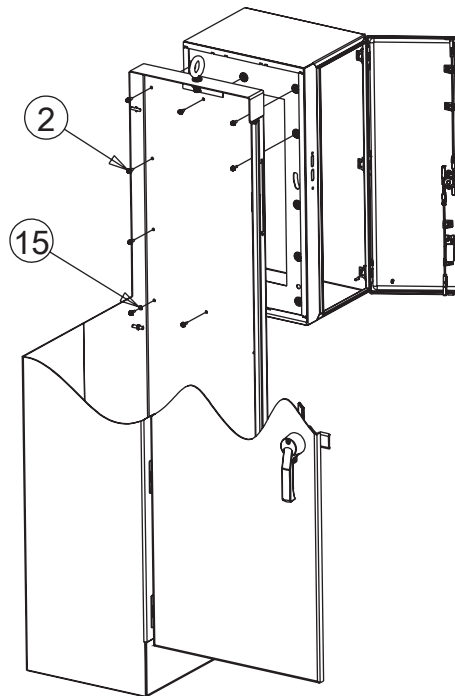

Figure 1C

Installing the Circuit Breaker/Disconnect Switch and Associated Hardware

1. Drill mounting holes in the panel for the specific disconnect switch/circuit breaker being installed. Additional holes may be required when using fused switches. See the device manufacturer's instructions.
2. Install the left-hand configuration circuit breaker mechanism or disconnect switch, trailer fuse block, and fuses onto the panel per the device manufacturer's instructions.
3. Install the populated panel into the Sequestr enclosure. Secure with the six previously saved hex nuts.
4. Punch, drill or cut holes side of the control enclosure to allow wires to pass through using approved gland(s). Add wiring from the load side of the trailer fuse block/circuit breaker to the existing wiring or the incoming power side of components in the control enclosure. Seal around the wires to maintain a Type 1 rating. Terminal blocks (ordered separately) are also available to aid in the effort.
5. Install conduit and wires to the line side of the circuit breaker/disconnect switch in the Sequestr enclosure.

Operating Handle Installation

(For cable operator handles installed in the control enclosure see next section).

1. For either cable operated or variable depth devices, install the device operating handle on the Sequestr enclosure flange following the device manufacturer's instructions.

Sequestr Defeater Arm and Cover Plate Installation

1. Install the defeater arm (Item 6) through the sliding cover plate (Item 13) as shown in Figures 2 and 3. (Note the curved end is on the top and pointing toward the front of the enclosure)
 - a. **Allen Bradley handle (see Figure 2):** Insert the Sequestr defeater arm (Item 6) through the curved slot in the enclosure side and secure it to the switch handle defeater lever with two screws supplied by Allen Bradley. If the spring interferes with the defeater bracket attach the end of the spring to the control rod, as shown, to provide clearance between the defeater bracket and the spring.

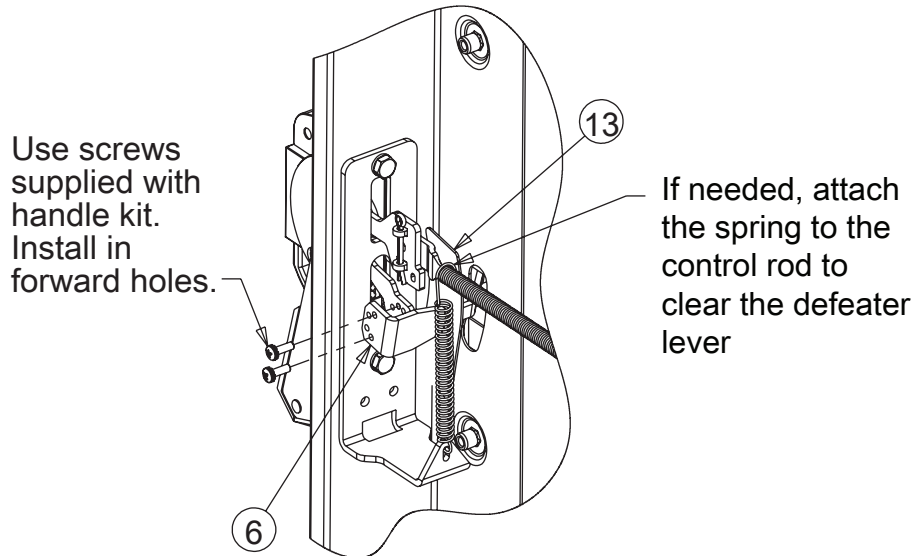

Allen Bradley Handle
Figure 2

- b. **Square D handle (see Figure 3A):** Insert the Sequestr defeater arm (Item 6) through the curved slot in the enclosure side and secure it to the switch handle defeater lever on the side of the defeater lever nearest the Sequestr enclosure wall with two screws supplied by Square D. The screws will pass through the defeater lever and thread into the Sequestr defeater arm. In order to provide clearance between the defeater arm and the spring, attach the longer end of the spring to the control rod at the beginning of the threads instead of the eye hook.

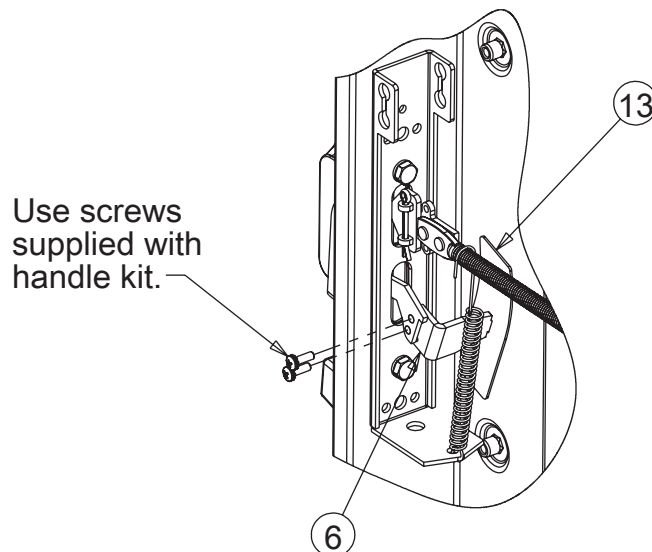

Square D Handle
Figure 3A

Device Operating Handle Installation

(For cable operator handles remaining in the control enclosure).

1. Install the operating handle and associated hardware in the control enclosure per the device manufacturers instructions.
2. Based on the length of the operating cable, determine if the loop in the cable will be in the control enclosure or in the Sequestr enclosure. Mark, cut, and deburr a hole in the wall of the control enclosure for the cable to pass through that maintains the manufacturers recommended bend radius without kinking or binding. A slot that will allow the cable to freely pass through at a reduced angle to the wall may be preferred. (See Figure 3B.) Note: If the cable cannot be disconnected from the switch or breaker operating mechanism it may be necessary make a cutout large enough for the device operating mechanism to pass through.
3. Pass the cable through the enclosure side wall and connect to the switch/breaker per manufacturer's instructions. If a larger hole/cutout was required, the installer may need to make and install a cover plate that has a slot for cable passage and maintains a Type 1 rating.
4. Install a Preferred Cutout Closure Plate (order separately from nVent HOFFMAN) in the Sequestr enclosure handle cutout.

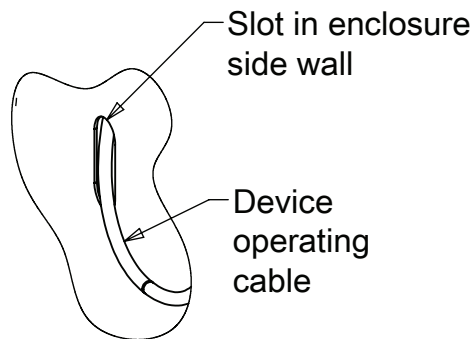
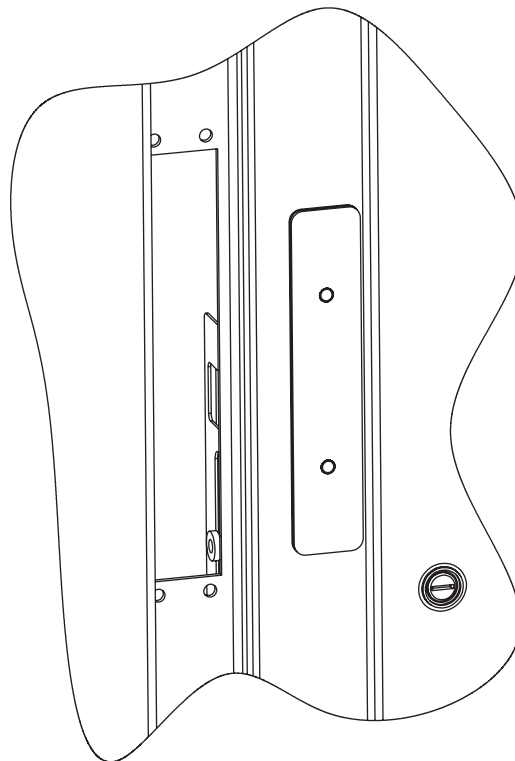

Figure 3B



Preferred Cutout Closure Plate

Defeater Slide Arm Installation

1. Referring to Figure 4, check the adjustment of the factory-installed control enclosure release mechanism, verify that the top of the door latch contacts the latch stop when the door is closed and the handle is fully latched.
2. Install Defeater Slide Arm:
 - a. Using one of the remaining M6x20 washer head cap screws (Item 2), install the screw through the shoulder spacer (Item 3) and the slide arm (Item 12) so the smaller diameter of the spacer fits through the slot of the arm. Install the screw just below the Sequestr defeater arm (Item 6) making sure the slide arm moves freely when the screw is tightened.
 - b. Attach the bottom of the slide arm over the two studs on the release mechanism with two flat washers (Item 10), and two KEPS lock nuts (Item 11). Do not tighten until all parts are adjusted.
 - c. Make an initial adjustment of the slide arm (Item 12) so it is approx. $\frac{1}{4}$ inch above the Sequestr defeater arm (Item 6) when the switch handle is in the OFF position. Adjust the length of the slide arm so the switch handle defeater releases just before the master door is completely latched. Lengthen the arm if the defeater releases too soon. Shorten the arm if the defeater releases too late.

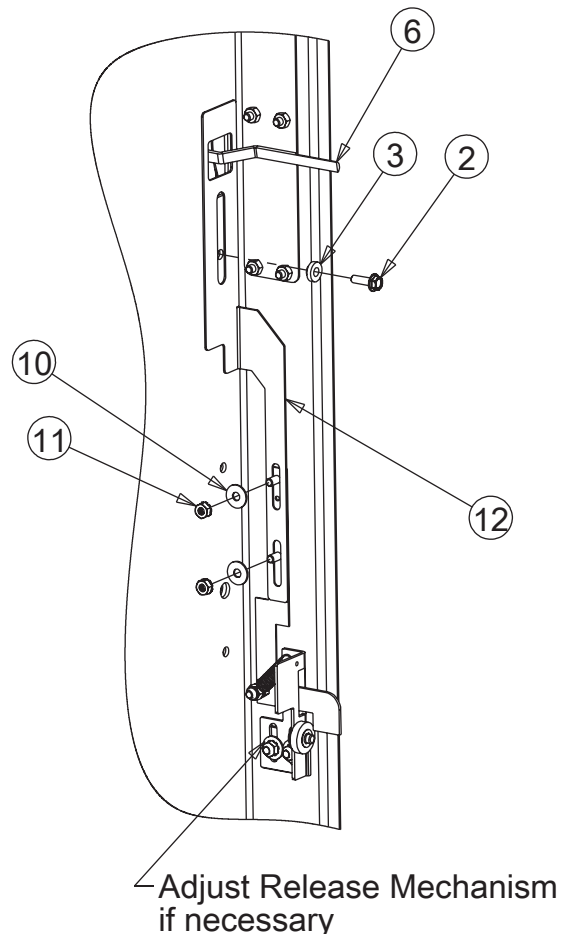

Figure 4

Install Control Enclosure Door Hook

1. Referring to Figure 5, install the control enclosure adjustable door hook (Item 7) onto the door of the control enclosure using two 10-32 screws (Item 8) and #10 flat washers (Item 9). Initially position the hook approximately two inches from the top of the door bracket.
2. Close the door and check that the hook engages the Sequestr defeater arm (Item 6) with the switch handle in the "ON" position.
3. Move the handle to the "OFF" position and verify the hook is released and the door can be opened.
4. Adjust the hook up or down to for proper engagement with the Sequestr defeater arm. Tighten all screws and nuts when the adjustments are complete.

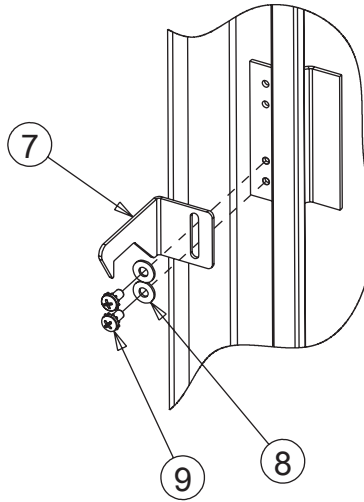

Figure 5

Interlock Installation

1. Referring to Figure 6A, with the interlock arm removed, install the control enclosure interlock (Item 1) with the shaft passing through the hole in the control enclosure and into the Sequestr enclosure. Secure the interlock with the two remaining M6x20mm washer head cap screws (Item 2)
2. Install the interlock arm onto the shaft so it protrudes out of the Sequestr enclosure door opening. It should be installed with the hook facing up and parallel with the arm on the opposite end of the shaft. Secure the arm with the screw provided. Apply Loctite 262 as indicated.

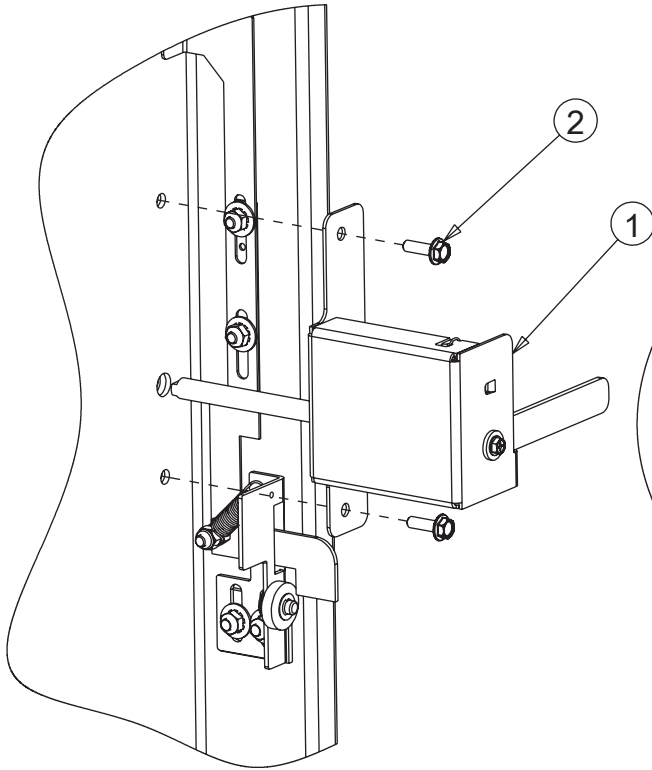

Figure 6A

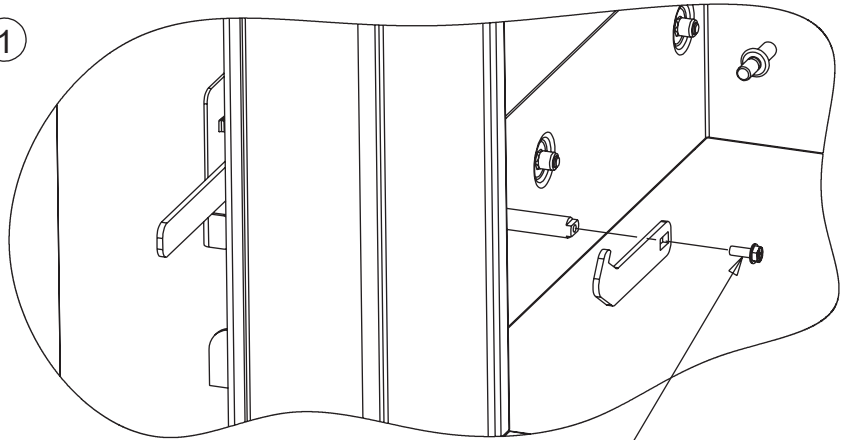

Figure 6B

Labeling

Add the derived power label (Item 4) to the control enclosure below the tipping warning label as shown Page 3 of this instruction. The arrow on the label should be pointing toward the Sequestr enclosure.

NOTE: Extra warning labels (Items 4 and 5) are included for the purpose of and should be applied after the enclosure is painted or the original label is destroyed. Customers should contact nVent for any additional warning labels in the event they cannot find the extra labels or need more.

Powering Up the System

1. Remove any component protective covering that may have been installed per step 3 of “Removing Old Hardware and Preparing the Control Enclosure” on page 4.
2. Verify the operator handle is in the “OFF” position.
3. Close the Sequestr enclosure door and latch securely. The interlock arm should rotate upward.
4. Close the control enclosure door and latch securely. The control enclosure door will now hold the interlock in the position and prevent the Sequestr door from being opened.
5. Restore power to the enclosure (possibly the disconnect on the bus bar).
6. Flip the operator handle on the Sequestr enclosure to the “ON” position using the appropriate right or left hand rule.
7. Verify that the machine / system operates with the new electrical connection.

Accessing the Enclosures

Opening the Control Enclosure Door with Power “ON”





1. Defeat the operator handle per the device manufacturer’s instructions.
2. Open the control enclosure door
3. Sequestr door can be opened after control enclosure door is opened.

Opening the Sequestr Enclosure Door with Power “OFF”

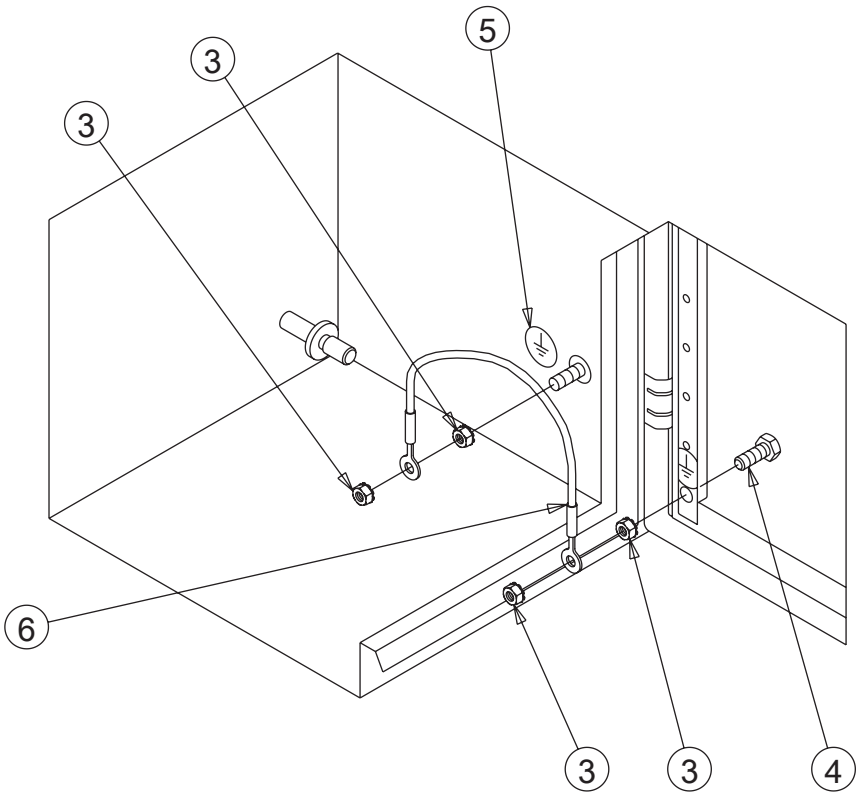
1. Open the master door on the control enclosure. Door stop arm will be free to rotate down and release the Sequestr door latch.
2. Open the Sequestr enclosure door.

Sequestr Enclosure Grounding

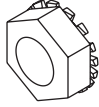
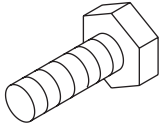

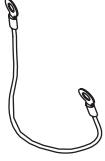
<p>1</p>  <p>(Panel mounting nut in enclosure)</p>	<p>2</p>  <p>(1x)</p>
<p>3</p>  <p>(6x)</p>	<p>4</p>  <p>(2x)</p>
<p>5</p>  <p>(2X)</p>	<p>6</p>  <p>Supplied by customer (0X)</p>

Sequestr Panel Installation / Grounding

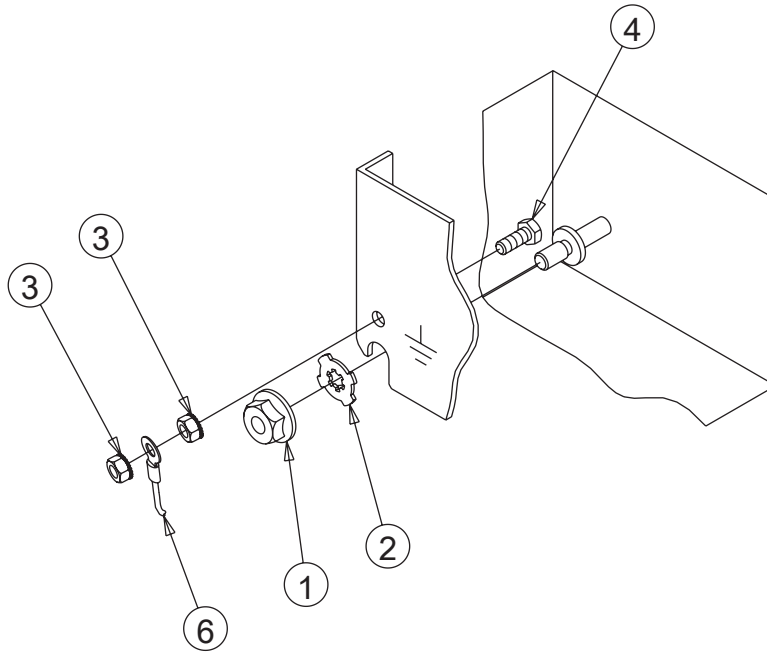

Hardware Kits

Shown are the proper installation procedures for grounding the doors, covers, and optional panels and mounting the optional side and back panels.

Ground wires (Item 6) are available from nVent Equipment Protection at nvent.com/HOFFMAN.

Repainting Instructions

Suggested Paints: The following paints typically provide superior adhesion qualities:

- Two Component Epoxies
- Two Component Polyurethanes
- Lacquers
- Acrylics
- Alkyd Baking Enamels
- Industrial Enamel

Surface Preparation: Wet wipe all surfaces to be painted with xylene solvent. Allow surfaces to flash dry three to five minutes. If a delay of greater than two hours occurs before painting, wet wipe again

Painting: Apply top coat per paint manufacturer's instructions. Allow adequate cure time between coats.

Allow top coat to cure completely prior to testing paint adhesion. Consult with the paint manufacturer for proper cure time.

Drill Patterns for 34-Inch Tall Sequestr Models

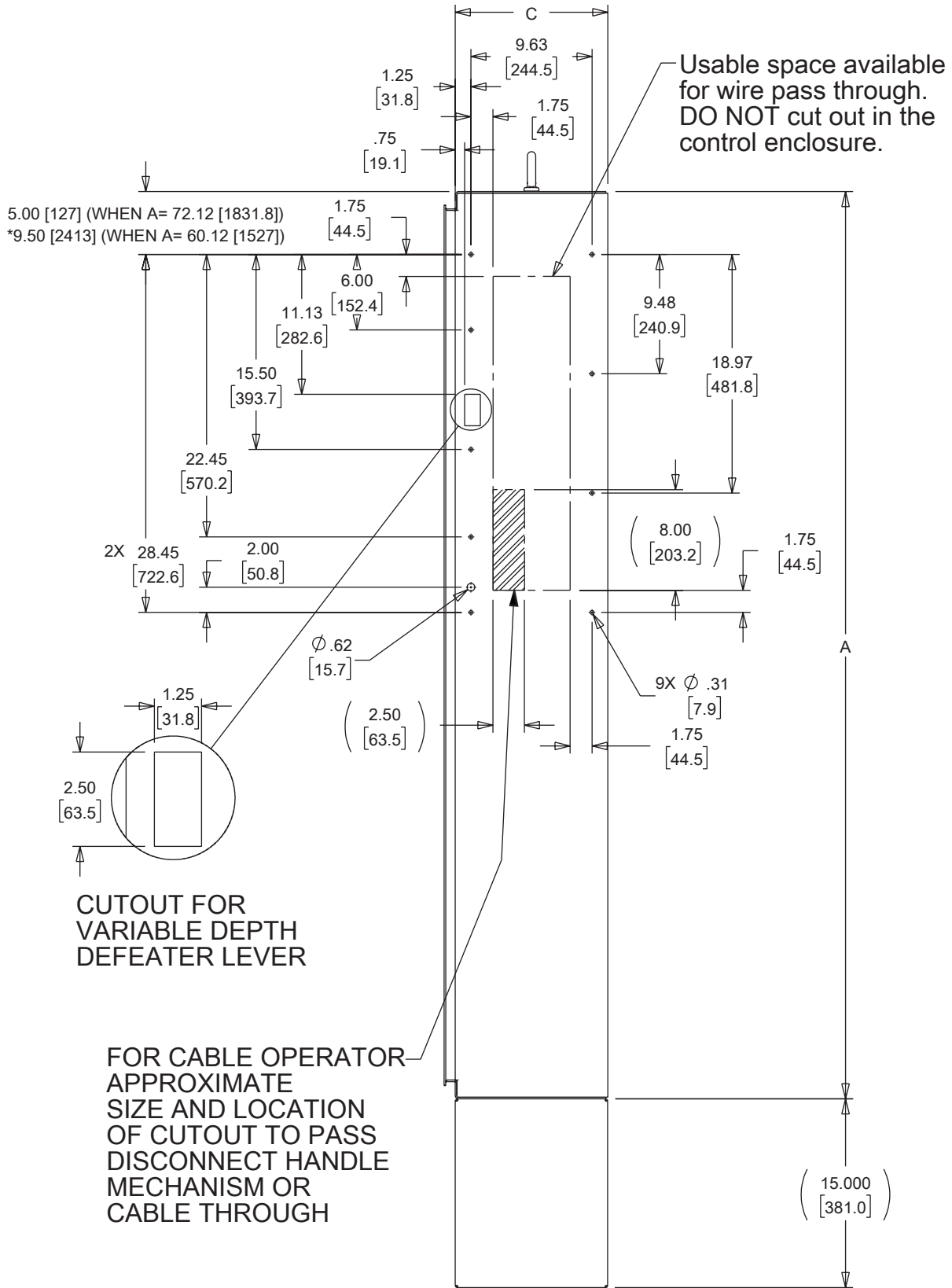

34 INCH SEQUESTR
 C = 12.12 [307.8]
 BUL- A21, A21S4

*NOTE: SEQUESTR CAN ONLY BE INSTALLED AS A CABLE OPERATED DEVICE ON 60 INCH ENCLOSURE

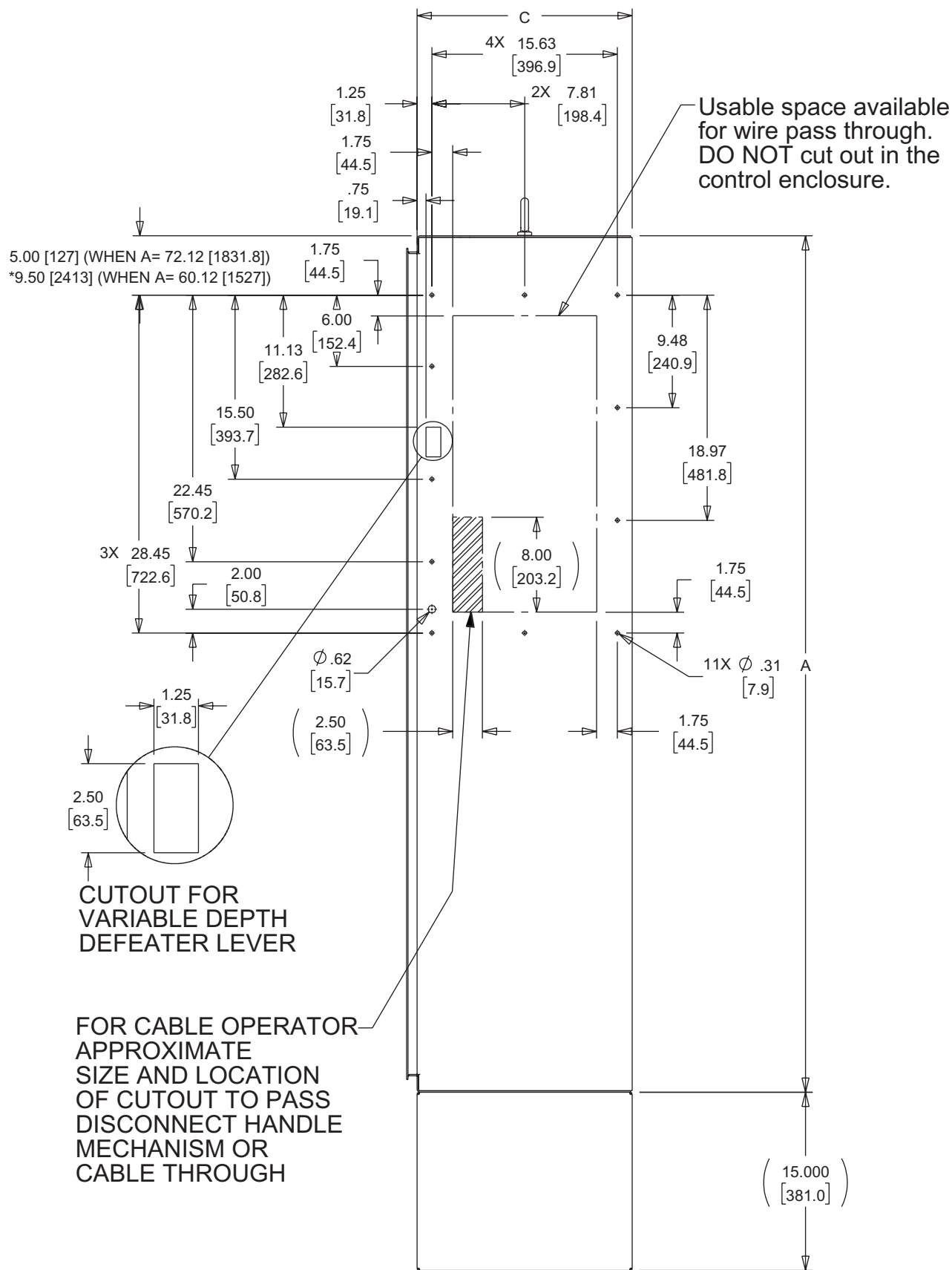

34 INCH SEQUESTR
 C = 18.12 [460.2]
 BUL- A21, A21S4

*NOTE: SEQUESTR CAN ONLY BE INSTALLED AS A CABLE OPERATED DEVICE ON 60 INCH ENCLOSURE

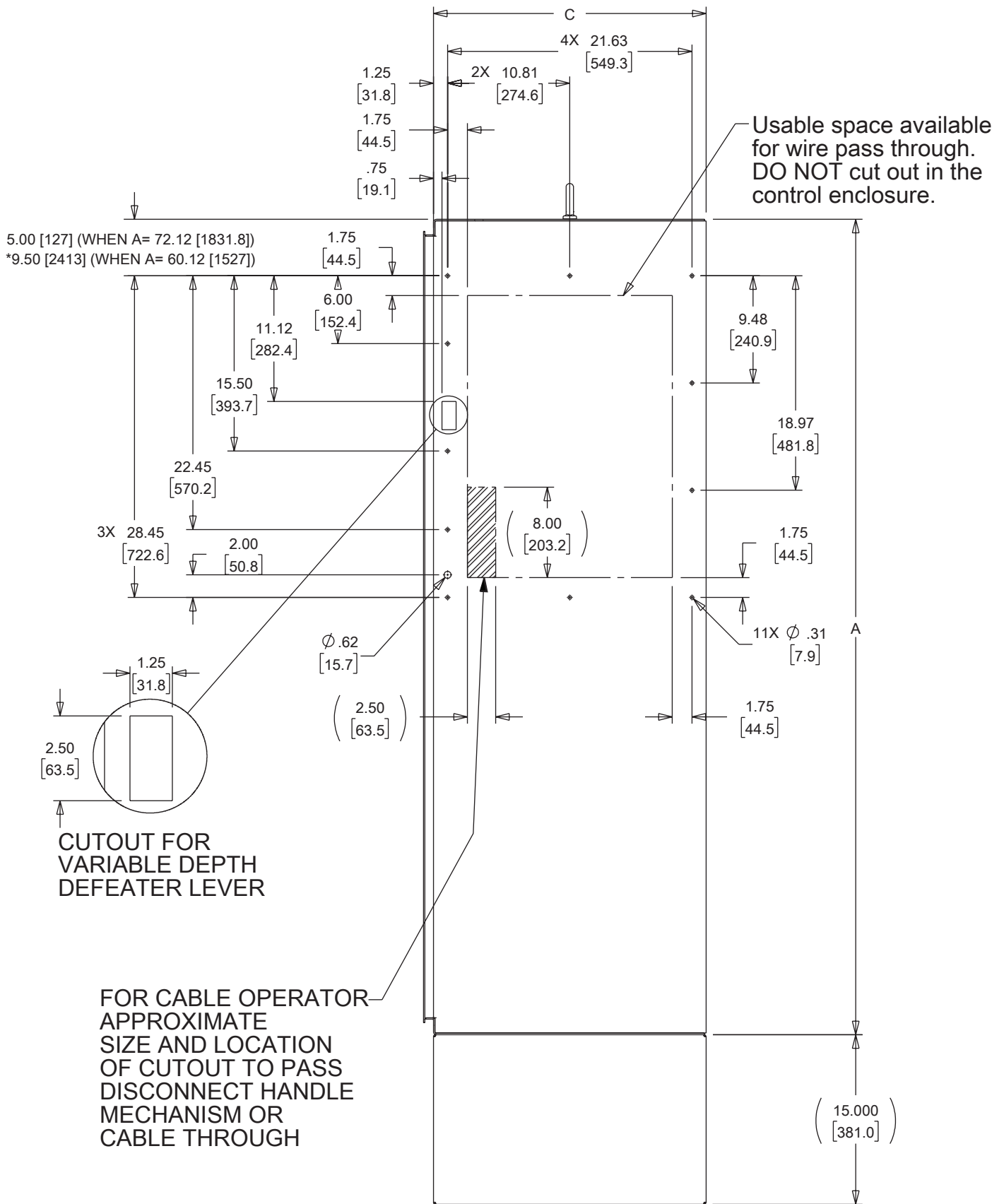

34 INCH SEQUESTR
 C = 24.12 [612.6]
 BUL- A21, A21S4

*NOTE: SEQUESTR CAN ONLY BE INSTALLED AS A CABLE OPERATED DEVICE ON 60 INCH ENCLOSURE

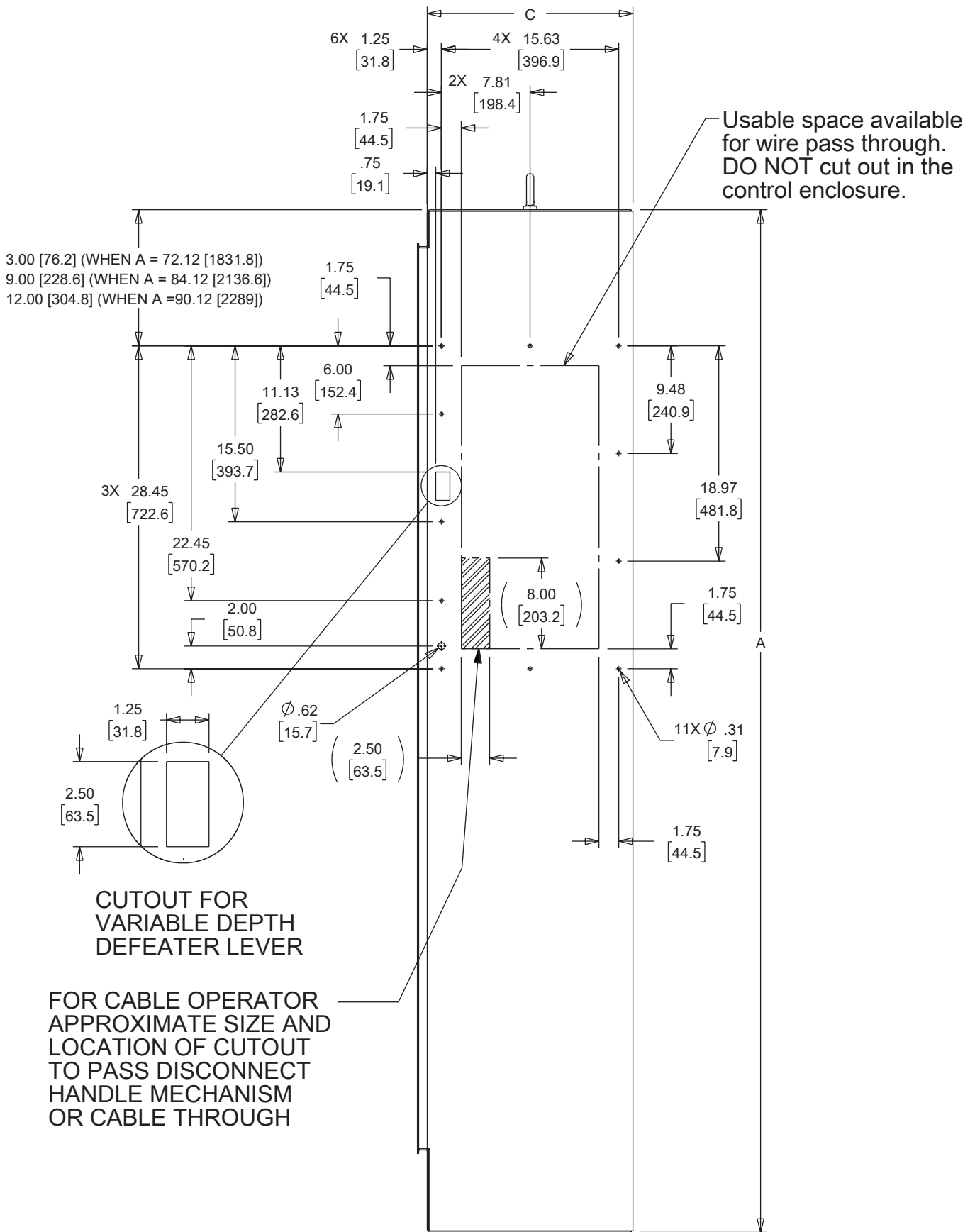

34 INCH SEQUESTR
 C = 18.12 [460.4]
 BUL - A28, A34, A4L3D, A28S4

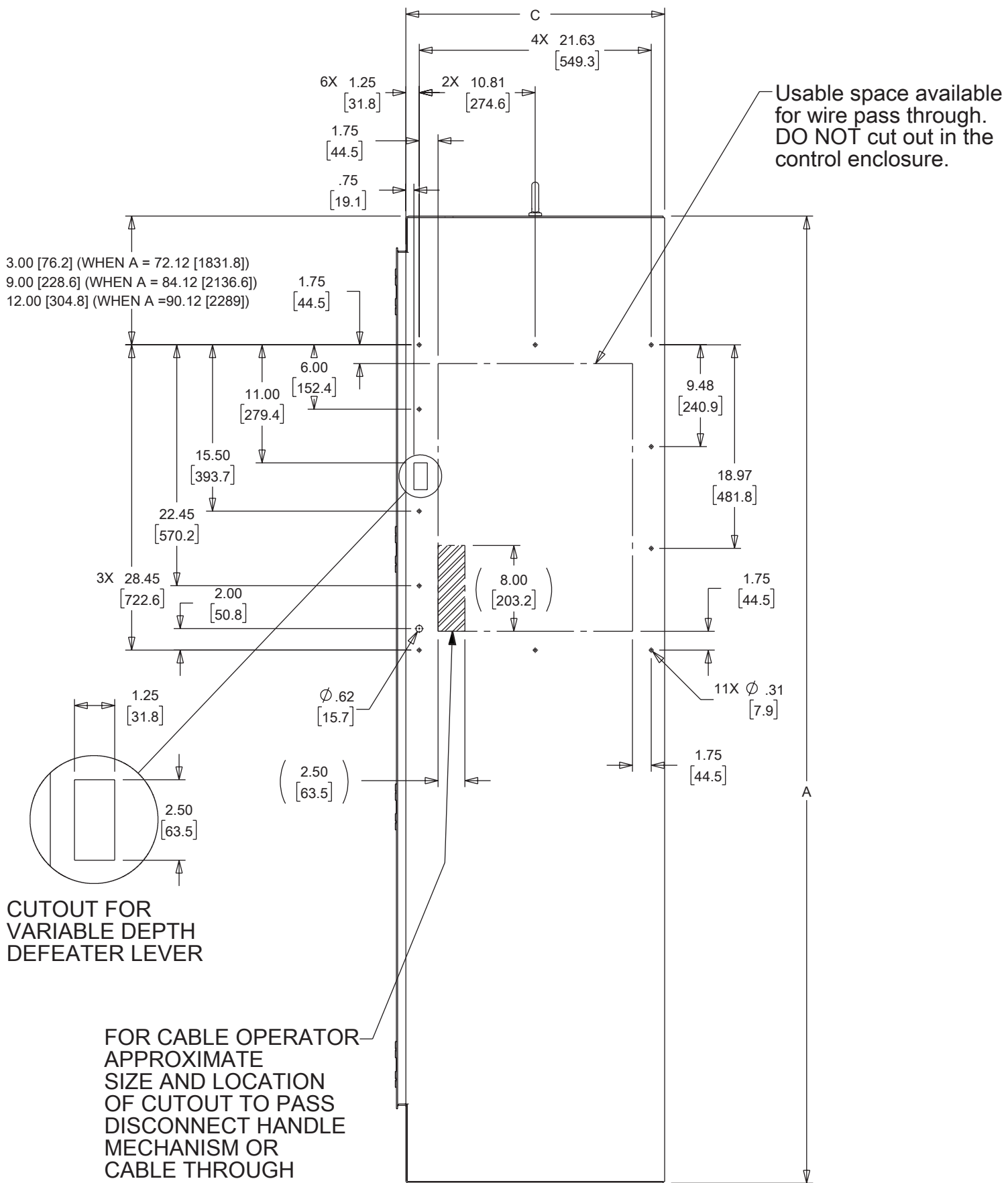

34 INCH SEQUESTR
 C = 24.12 [612.6]
 BUL - A28, A34, A4L3D, A28S4

Cutout Template Dimensions for 34-Inch Tall Sequestr Models

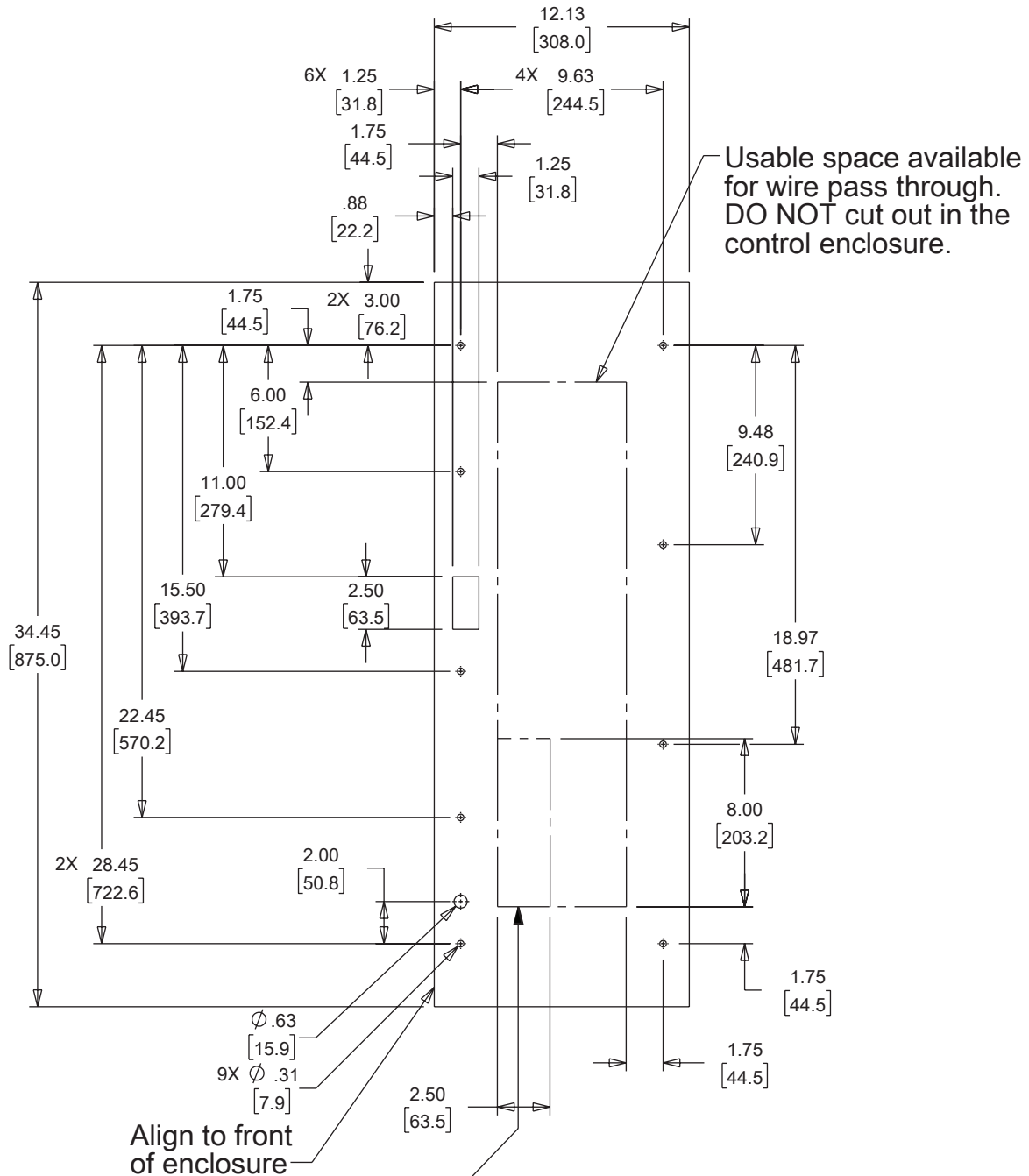

FOR CABLE OPERATOR APPROXIMATE SIZE AND LOCATION OF CUTOUT TO PASS DISCONNECT HANDLE MECHANISM OR CABLE THROUGH

TEMPLATE FOR 34 X 12 SEQUESTR
(1:1 scale downloadable template is available at nVent/hoffman.com)

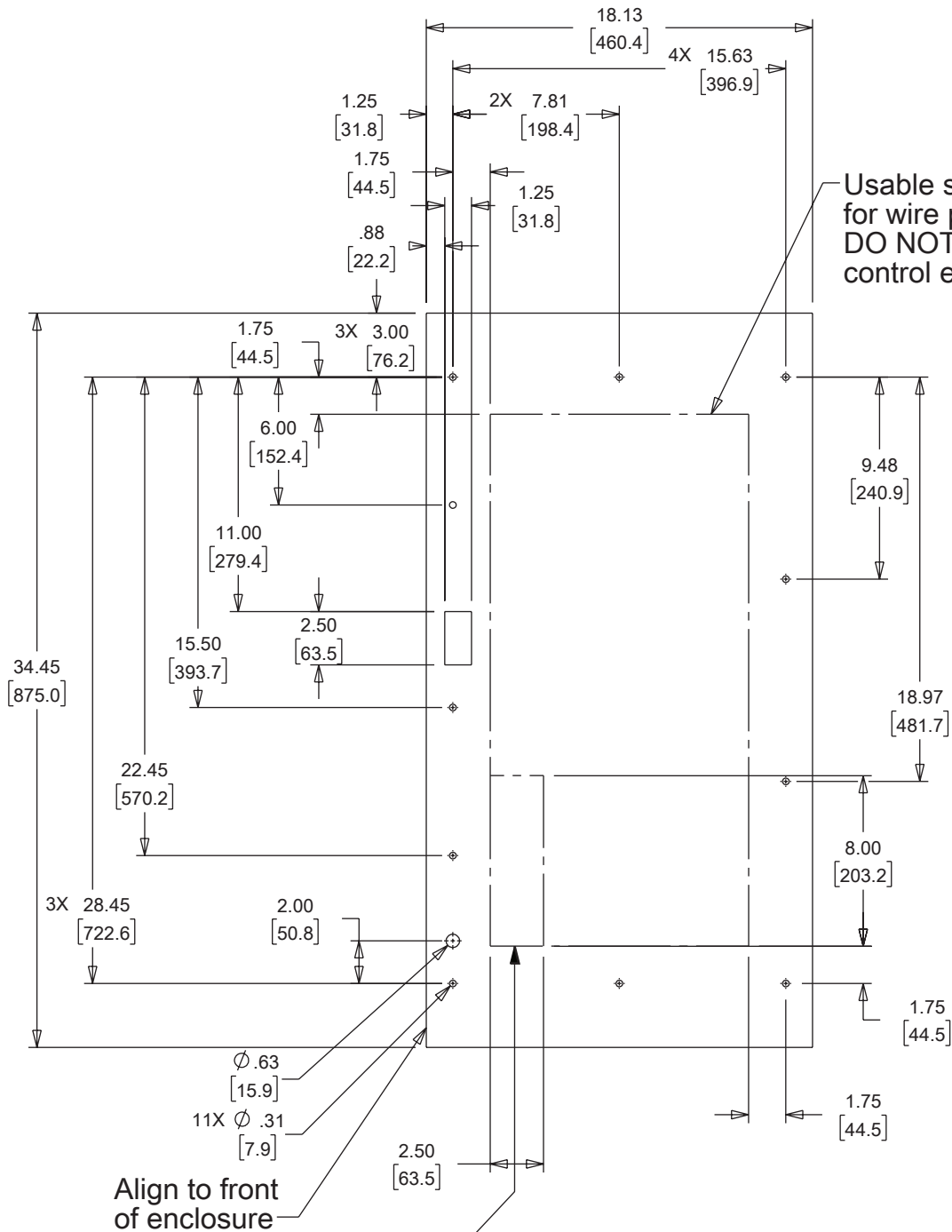

TEMPLATE FOR
34 X 18 SEQUESTR
(1:1 scale downloadable template is available at nVent/hoffman.com)

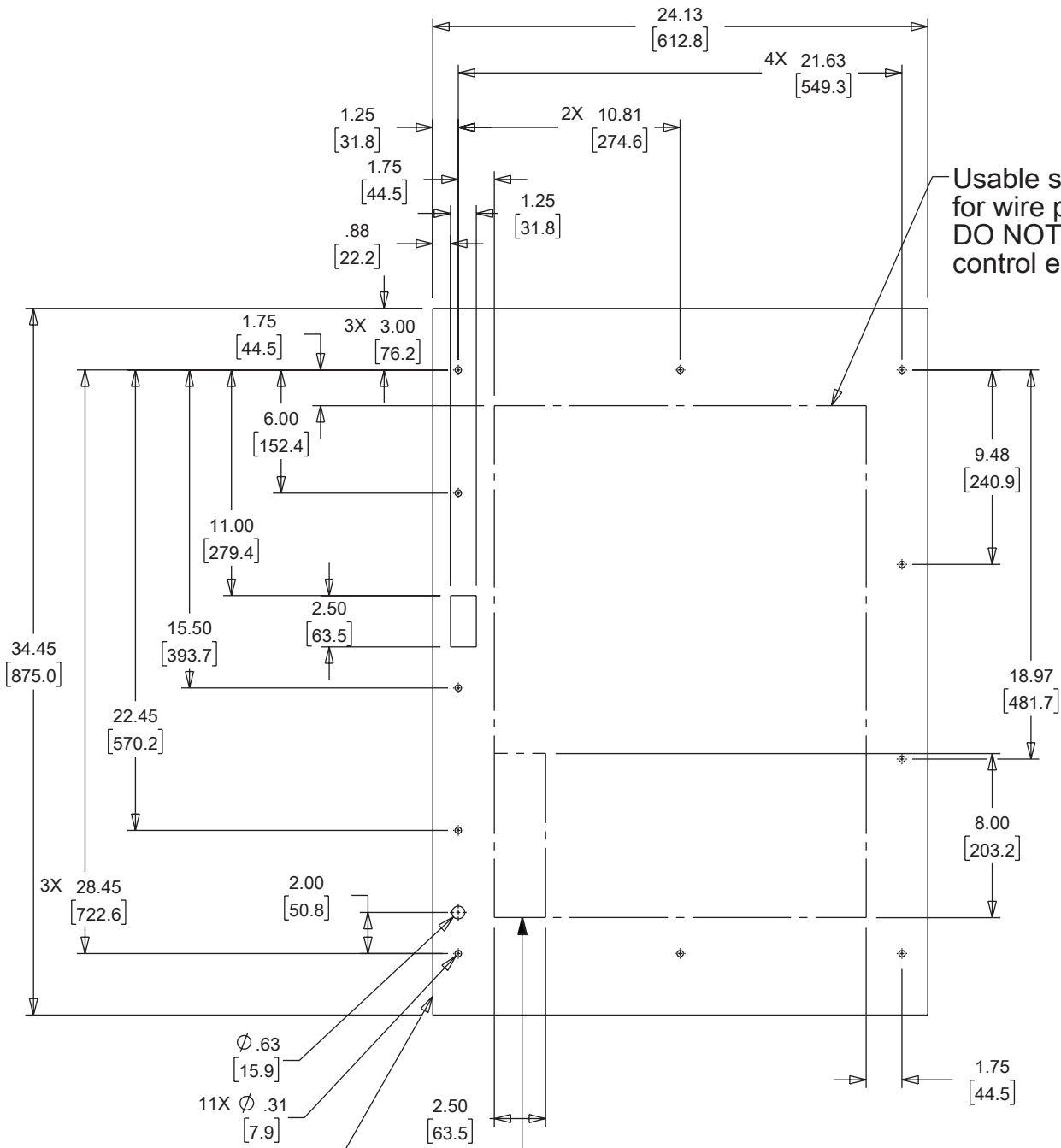

Usable space available for wire pass through. DO NOT cut out in the control enclosure.

Align to front of enclosure

FOR CABLE OPERATOR APPROXIMATE SIZE AND LOCATION OF CUTOUT TO PASS DISCONNECT HANDLE MECHANISM OR CABLE THROUGH

TEMPLATE FOR 34 X 24 SEQUESTER (1:1 scale downloadable template is available at nVent/hoffman.com)

