

RAYCHEM

EMK-XC-USA

ElectroMelt Power Connection & End Seal Kit Installation Instructions

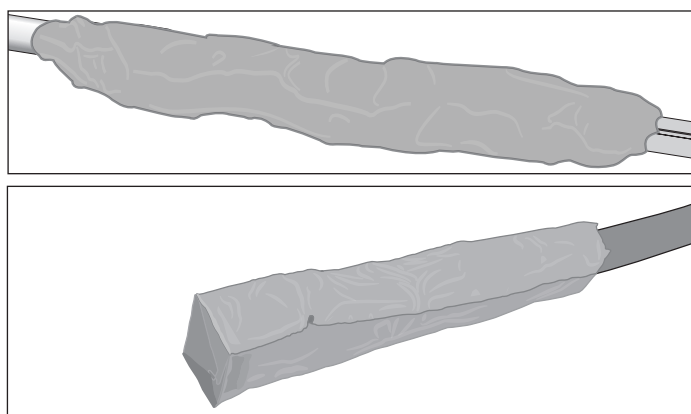

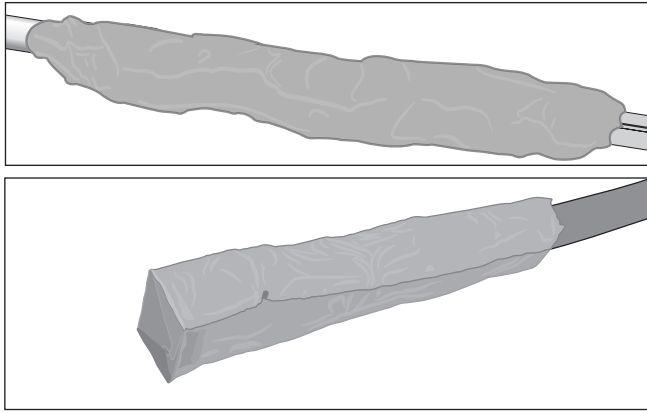

DESCRIPTION

The nVent RAYCHEM EMK-XC-USA Power Connection and End Seal Kit is for use with nVent RAYCHEM EM2-XR heating cable. Materials for one power connection and one end seal are included in the kit. This document should be used in conjunction with the ElectroMelt System Design Guide (H53393) and ElectroMelt System Installation and Operation Manual (H58086).

For technical support call nVent at (800) 545-6258.

TOOLS REQUIRED

- Needle-nose pliers
- Utility knife
- Diagonal cutters
- Heat gun or propane torch
- Wire cutter
- Slip Joint pliers
- Non-insulated Crimper
 - Multi-Comp KST2000D-1322 or
 - Ideal 30-429
- Small screwdriver

APPROVALS

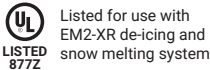

KIT CONTENTS

Item	Qty	Description
A	2	Heat shrinkable tube: 1/8 x 1 1/2 in (3 x 38 mm)
B	1	Heat shrinkable tube: 1/2 x 1 1/2 in (13 x 38 mm)
C	2	Non-insulated 14/16 AWG - 8 AWG butt splices
D	3	Heat shrinkable tube: 3/8 x 1 3/8 in (10 x 41 mm)
E	12	Mastic strips 1 x 3 in (25 x 76 mm)
F	1	Non-insulated 8 AWG - 10/12 AWG butt splice
G	1	Heat shrinkable tube - grn/yel: 1/4 x 1 1/2 in (6 x 38 mm)
H	1	Heat shrinkable tube - adhesive lined: 1 x 8 in (25 x 203 mm)
I	1	Heat shrinkable tube: 1 1/2 x 12 in (38 x 305 mm)
J	1	Heat shrinkable tube: 1 1/2 x 5 in (38 x 127 mm)
K	1	End seal plug
L	1	Power connection wire 8 AWG 15 ft (4.6 m)
M	1	Heat shrinkable cap: 1/2 in x 1 1/2 in (12.7 x 38 mm)
N	1	Heat shrinkable tube: 1 1/2 x 9 in (38 x 230 mm)
O	2	"Electric Deicing and Snow Melting" labels
P	2	Aluminum tape for end seal
Q	4	Aluminum tape for power connection

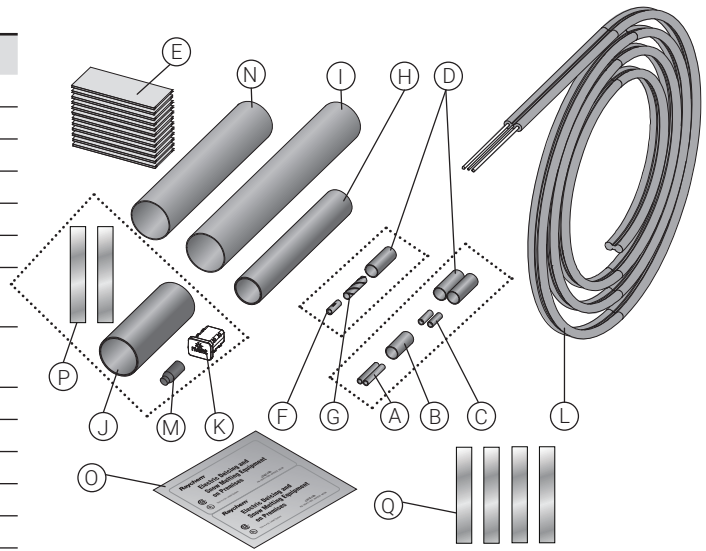

WARNING:

The heating cable is an electrical device that must be installed correctly to ensure proper operation and to prevent shock or fire. Read these important warnings and carefully follow all of the installation instructions.

- To minimize the danger of fire from sustained electrical arcing if the heating cable is damaged or improperly installed, and to comply with nVent, agency certifications, and national electric codes, ground-fault equipment protection must be used. Arcing may not be stopped by conventional circuit breakers.
- Component approvals and performance are based on the use of nVent specified parts only. Do not use substitute parts or vinyl electrical tape.
- The black heating-cable core is conductive and can short. It must be properly insulated and kept dry.

- Damaged bus wires can overheat or short. Do not break bus wire strands when scoring the jacket or core.
- Keep components and heating-cable ends dry before and during installation.
- Bus wires will short if they contact each other. Keep bus wires separated.
- Heat-damaged components can short. Use a heat gun or a torch with a soft, yellow, low-heat flame, not a blue focused flame. Keep the flame moving to avoid overheating, blistering, or charring the heat shrinkable tubes. Avoid heating other components. Replace any damaged parts.
- Megohmmeters operate at high voltage. This voltage is hazardous and possibly lethal. Read and follow all instructions included with the instrument you are using.

CAUTION:

HEALTH HAZARD: Overheating heat shrinkable tubes will produce fumes that may cause irritation. Use adequate ventilation and avoid charring or burning. Consult MSDS RAY3122 and ITCSN for further information.

CHEMTREC 24-hour emergency telephone:

(800) 424-9300

Non-emergency health and safety information:

(800) 545-6258.



RAY3122



ITCSN

POWER CONNECTION

Heating Cable Construction

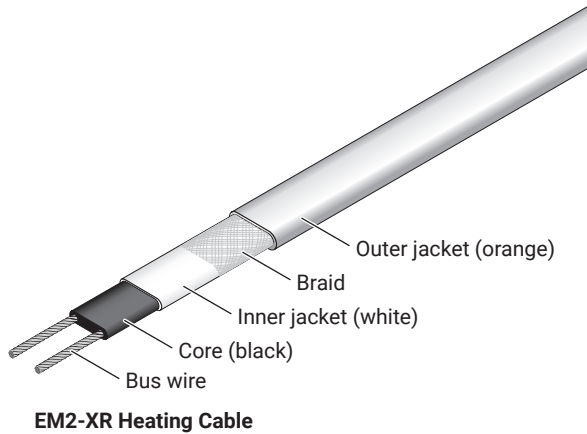

1

Instructions for using a heat gun or torch:

- Follow safety precautions provided with heat gun or torch.
- When using a torch use a soft yellow, low-heat flame. Apply just enough heat to do the job.
- Keep torch or heat gun moving continuously to distribute the heat evenly to avoid overheating, blistering or charring the heating cable and heat-shrinkable tubes.
- Replace any heat-damaged parts.

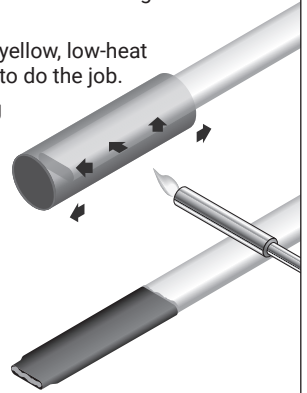

2

- Slide 9 inch (230 mm) (Item N), then 12 inch (305 mm) (Item I) and then 8 inch (203 mm) (Item H) heat shrinkable tubes over the end of the heating cable.

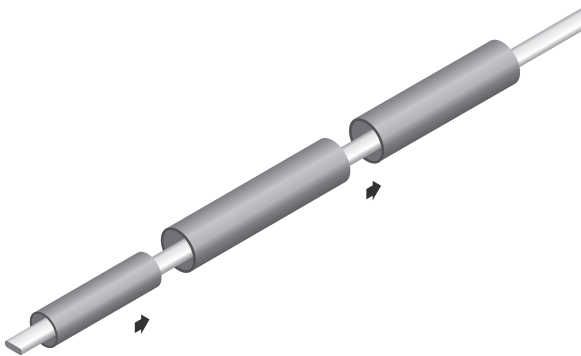

3

WARNING: Do not cut into braid or inner jacket. This could result in a short circuit.

- Score around outer jacket 3 1/4 inches (80 mm) from end. Make one lengthwise score as shown.
- Be sure to make a 90 degree perpendicular cut.

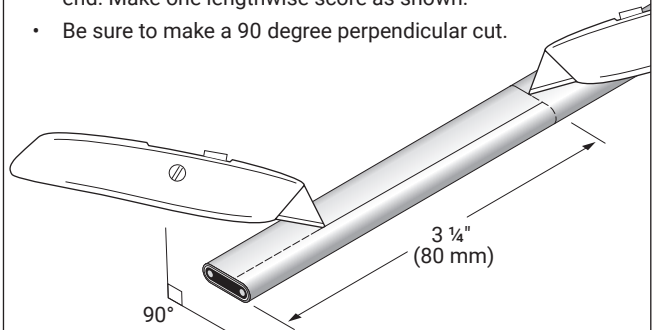

4

WARNING: Fire or Shock Hazard. See Step 1 for proper heating techniques.

- **Gently** heat end of cable to loosen bond between outer jacket and braid.

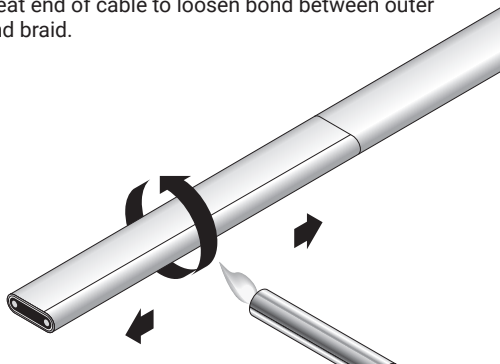

5

- Use slip joint or blunt nose pliers to pull outer jacket from braid.
- Rewarm the outer jacket as needed throughout the process to keep it pliable and reduce sticking to the braid.

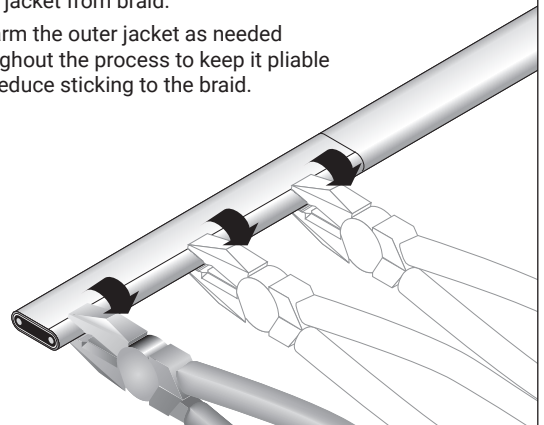

6

- Roll outer jacket back around heating cable to remove.
- This step is craft sensitive and gentle heating makes it easier.
- The jacket is pinched with the pliers towards the edge of the cable, not pinching down on the interior cable.
- The pinching operation should be performed from each side of the cable cut towards the narrow edge.
- Once it is pinched from each side to the edge fully, it can be removed peeling it off the back in one piece.
- Rewarm the outer jacket as needed throughout the process to keep it pliable and reduce sticking to the braid.

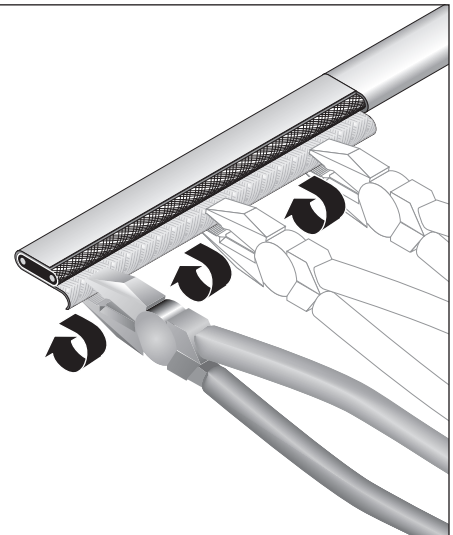
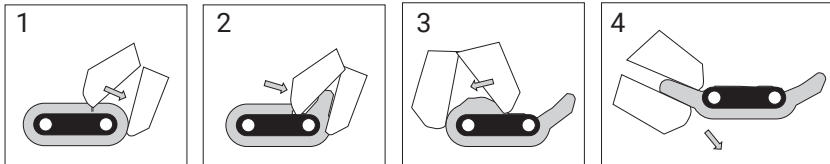

7

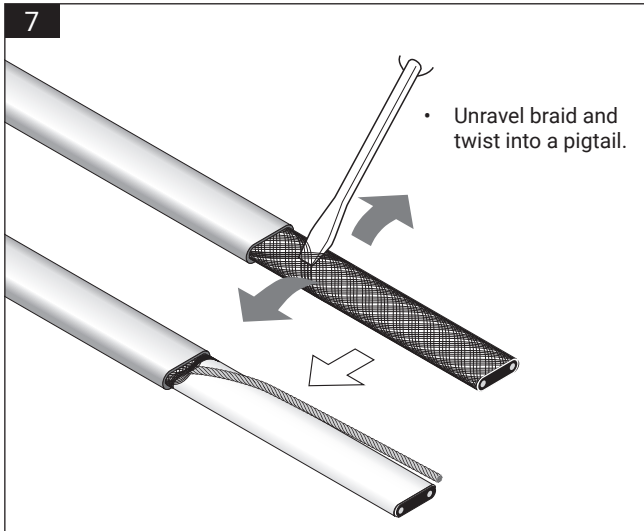

- Unravel braid and twist into a pigtail.

8

WARNING: Do not cut or damage bus wires. Damaged wires can overheat or short.

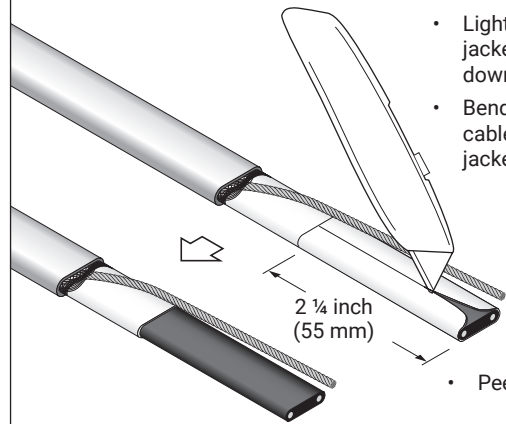

- Lightly score inner jacket around and down as shown.
- Bend heating cable to break jacket at score.

- Peel off jacket.

9

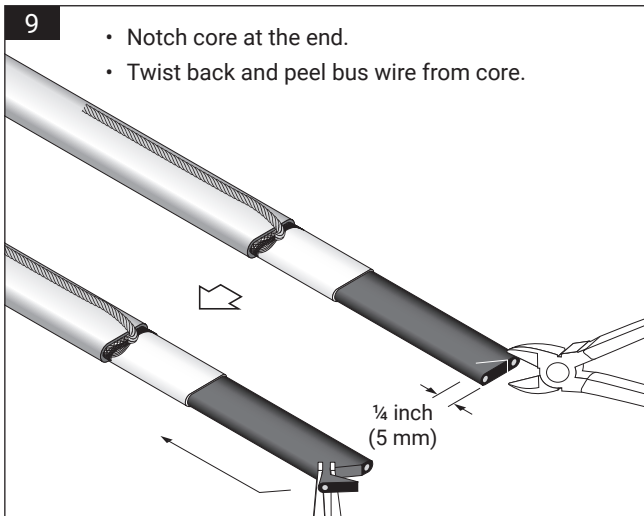

- Notch core at the end.
- Twist back and peel bus wire from core.

10

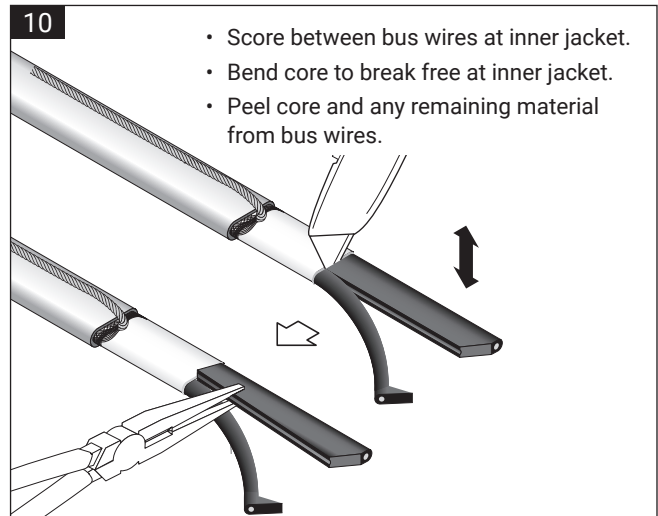

- Score between bus wires at inner jacket.
- Bend core to break free at inner jacket.
- Peel core and any remaining material from bus wires.

11

- Slide 1/8 inch (3 mm) diameter tubes (Item A) over bus wires.



12

- Ensure heat shrinkable tubes (Item A) are fully against cable core.
- Shrink onto bus wires.
- Slide green/yellow tubing (Item G) over braid.

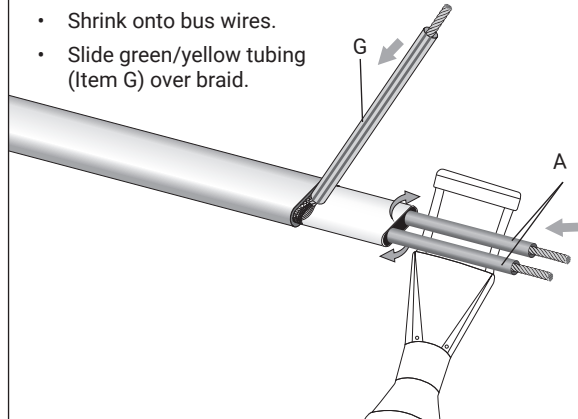

13

- Position 1/2 x 1 1/2 inch (13 x 38 mm) heat shrinkable tube (Item B) midway over end of cable core where wires exit.
- Shrink in position.

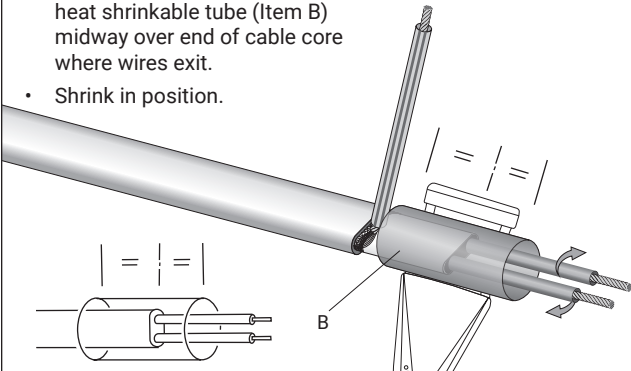

 NOTE: Item B has a similar appearance to Item D, but differs in diameter and texture. See Step 1 for proper heating techniques.

14

- While still hot from shrinking, gently squeeze tube between wires to form a "Y" branch seal.
- Keep bus wires as straight as possible.
- Hold 10 seconds.
- Squeeze tube base to seal around core.

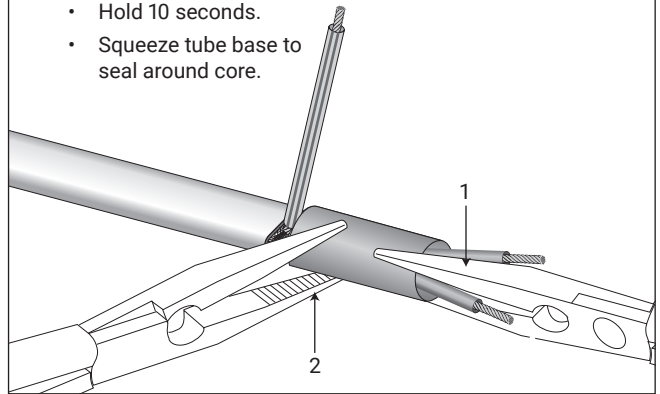

15

- Cleanly trim braid and wire tips to indicated lengths.

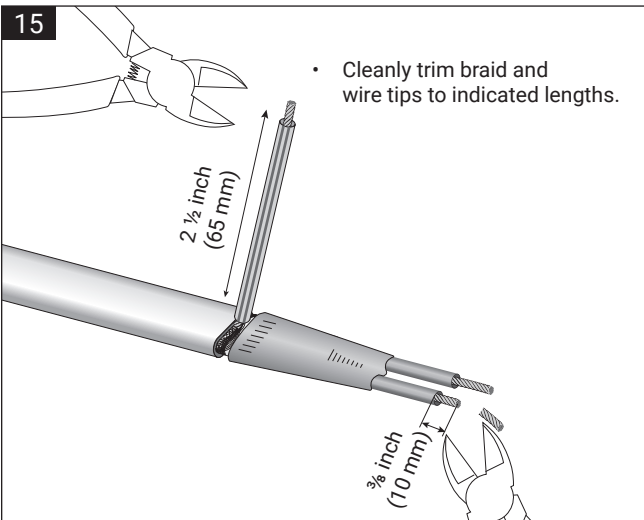

16

- Ensure heat shrinkable tubes (Items N, H and I) are on heating cable before proceeding.

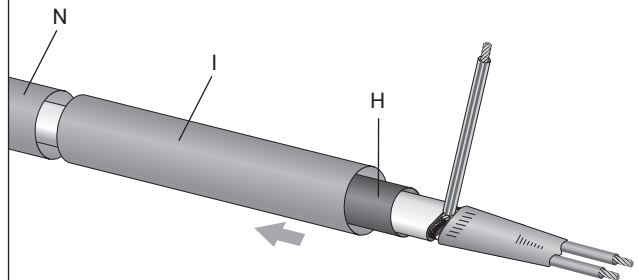

17

- Prepare power cable (Item L) stripping outer jacket and outer 8 AWG conductor wires to indicated lengths.
- Inspect cut area for to ensure no damage.

Non-insulated ground wire

3/8 inch (10 mm)

2 3/8 inch (60 mm)

⚠ WARNING: Do not cut inner conductor insulation.

18

- Insert non-insulated butt splices 14/16 AWG-8 AWG (Item C) onto bus wire ends and crimp firmly.
- Repeat with (Item F) non-insulated 8AWG -10/12 AWG butt splice on ground wire.

C

F

C

⚠ WARNING: Use only the splices supplied with this kit and one of the crimping tools specified on page 1. Check each crimp for loose or broken wire strands. If more than one loose or broken strand is found, the connection must be remade.

19

- Place heat shrinkable tubes (Item D) over conductors.

D

20

- Insert heating cable conductor ends into 14-16 AWG-8 AWG non-insulated butt splices.
- Hold in position and crimp very firmly linking the two cables.
- Only use specified crimping tool (page 1).

⚠ WARNING: Use only the splices supplied with this kit and one of the crimping tools specified on page 1. Check each crimp for loose or broken wire strands. If more than one loose or broken strand is found, the connection must be remade.

21

- Slide heat shrinkable tubes (Item D) over non-insulated splices (Item C). Tube must cover power connection evenly.

22

- Heat shrink tubes (Item D) over splices fully allowing internal adhesive to flow sealing around wires.
- Repeat step 14 if the core sealer opens up during this step.

23

- Wrap mastic (Item E) squeezing against base of braid and over the end of the shrunken core tube (Item B). Do not stretch mastic.

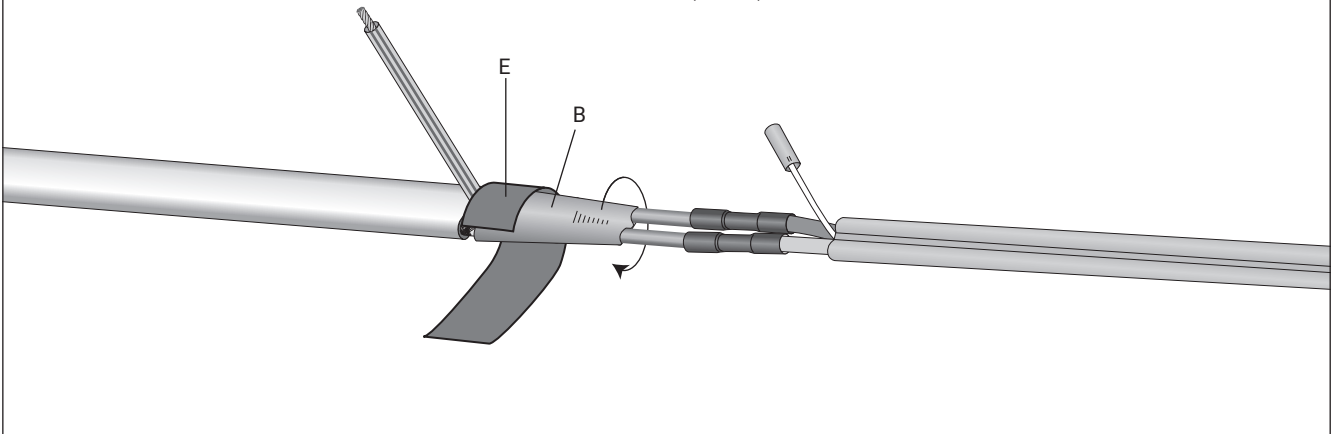

24

- Fold one mastic (Item E) piece lengthwise to form a narrow band of double thickness.
- Wrap mastic (Item E) between and around each individual conductor up against power cables' outer insulation.

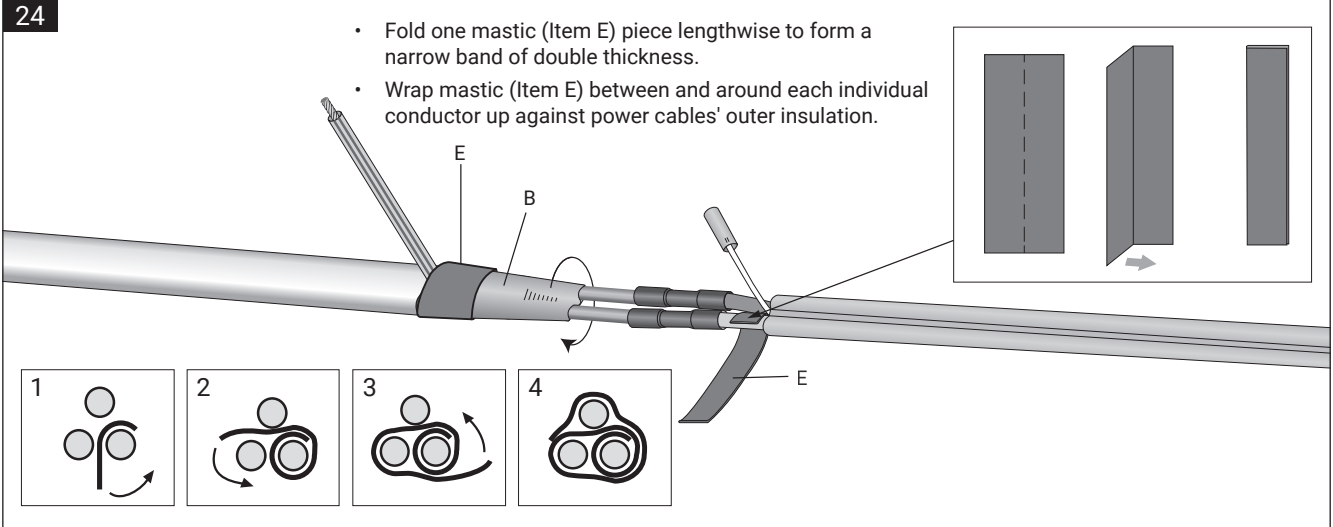

25

- Ensure heat shrinkable tube (Item D) is placed over power cables' ground wire before proceeding.

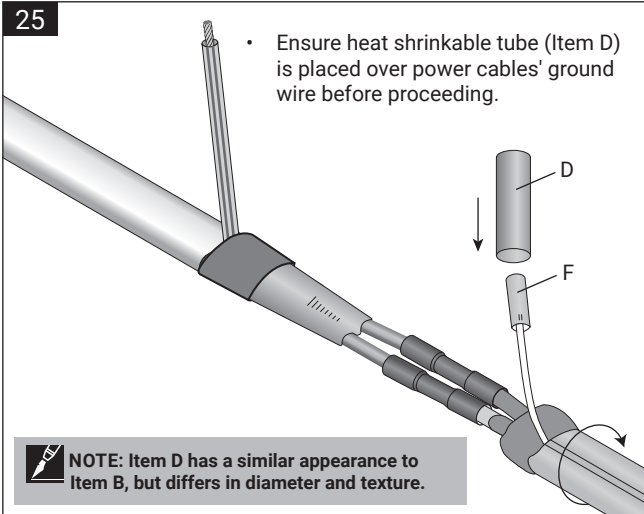

26

- Insert heating cable braid into non-insulated 8 AWG splice (Item F) and firmly crimp.
- Slide heat shrinkable tube (Item D) and center over non-insulated butt splice.

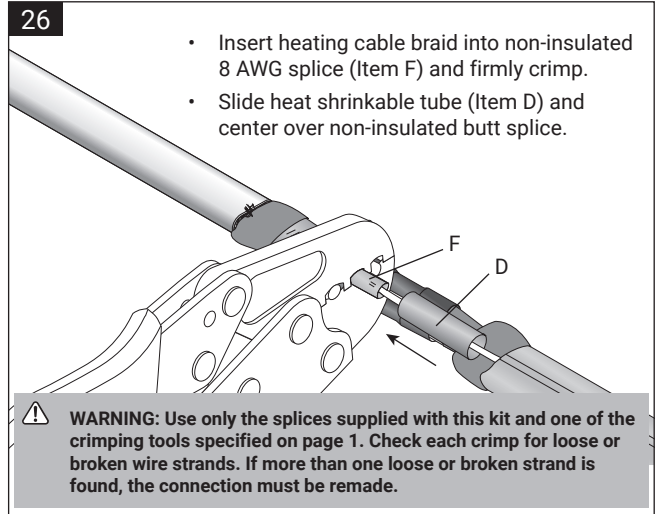

27

- Heat shrink tube (Item D) over splice fully allowing internal adhesive to flow sealing around wires. Yellow/green tubing (Item G) may be shrunk, but it is not required.
- Repeat step 14 if the core sealer opens up during this step.

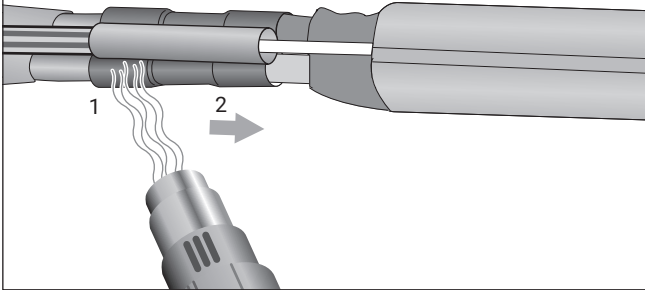

28

- Add an additional mastic (Item E) covering both the base of the braid and body of the heating cable.

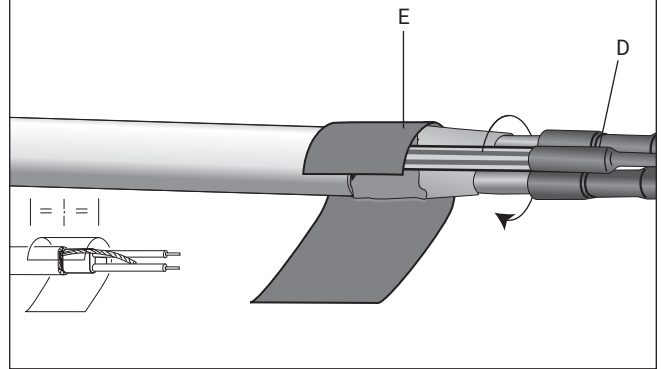

29

- Cut two mastic strips (Item E) into half to make four pieces
- Roll up into tight spirals for placement on the power cables' (Item L) external groove.

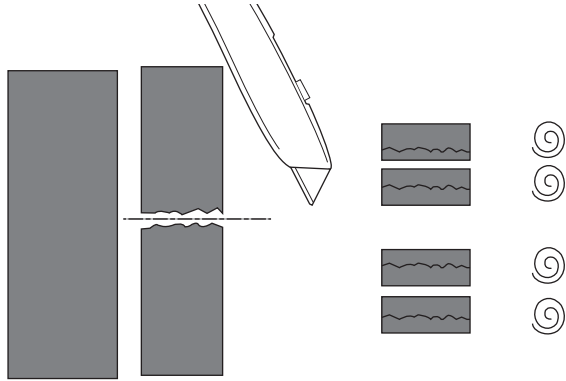

30

- Add rolled mastic spiral pieces (Item E) on both sides of the power cable (Item L).
- Depress into place using mastic release liner under fingers squeezing spiral into cable groove on each side.

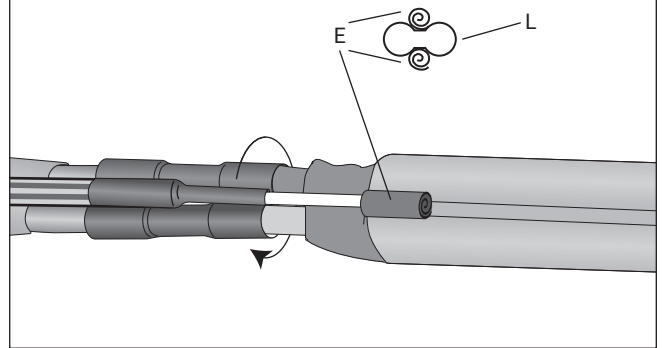

31

- Add additional mastic (Item E) over prior wrap covering region where wires exit and body of cable.

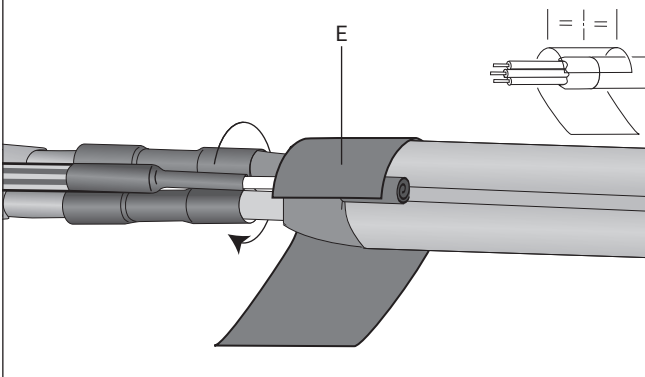

32

- Slide 8" heat shrinkable tube (Item H) centering between mastic bands.
- Shrink into position working from the tube center towards each end.

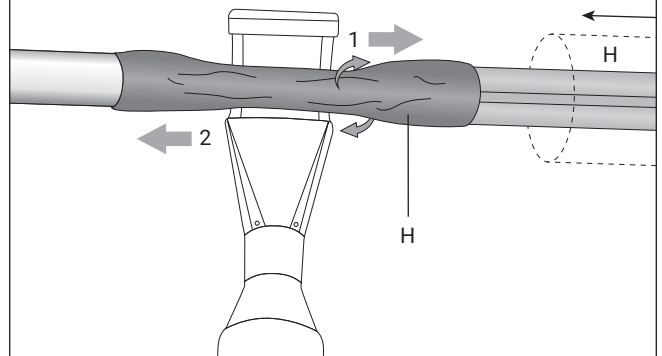

33

- Add rolled mastic spiral pieces (Item E) on both sides of the power cable (Item L).
- Depress into place using mastic (Item E) release liner under fingers squeezing spiral into cable groove on each side.

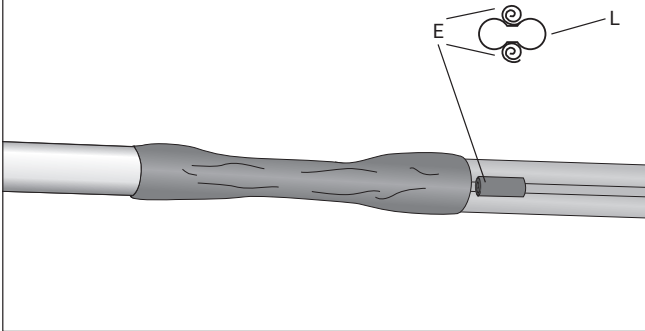

34

- Wrap the body of each cable with a mastic (Item E) up against sides of tube.

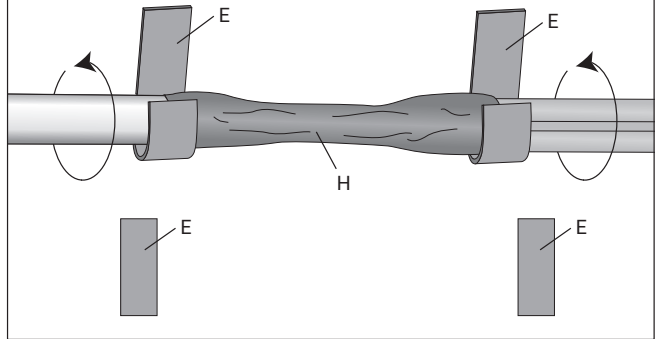

35

- Squeeze heat shrinkable tubing (Item I) if necessary to slide tube over mastic bands (Item E) and position evenly over connection.
- Do not drag mastic while sliding tube in position.

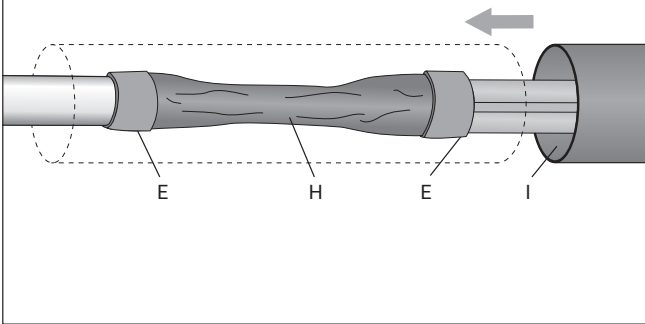

36

- Shrink (Item I) tube beginning in the center.
- Work towards each end to expel air while shrinking.

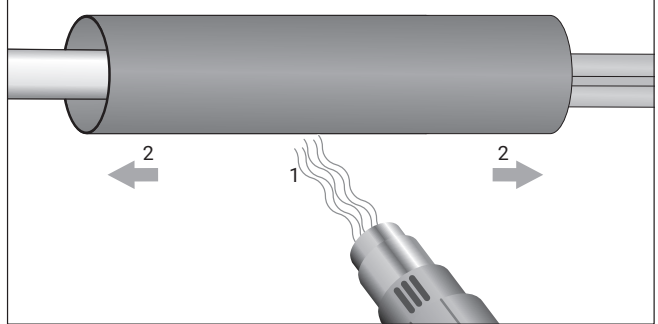

37

- Overlap the 4 pieces of aluminum tapes (item Q) by 2" inch lengthwise and 1/4" widthwise

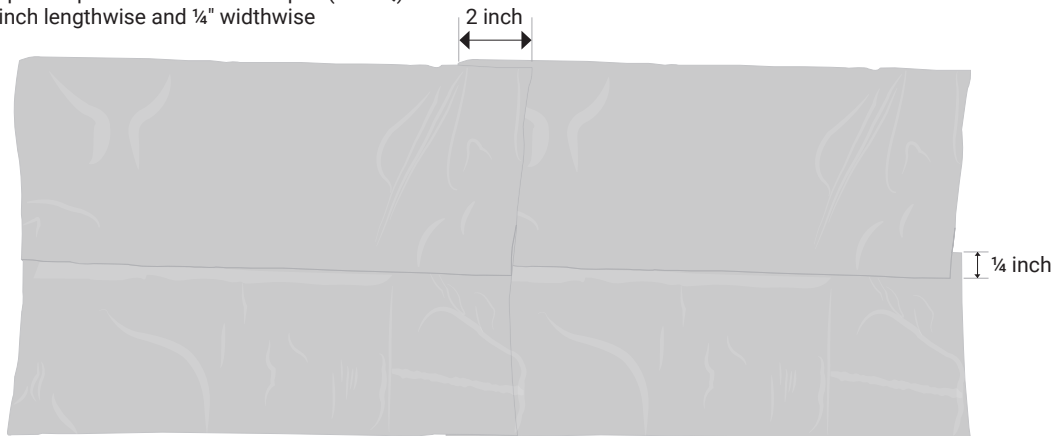

38

- Press and form the aluminum tapes onto the heat shrink tube. Ensure the heat shrink tube is completely covered by the aluminum tapes.

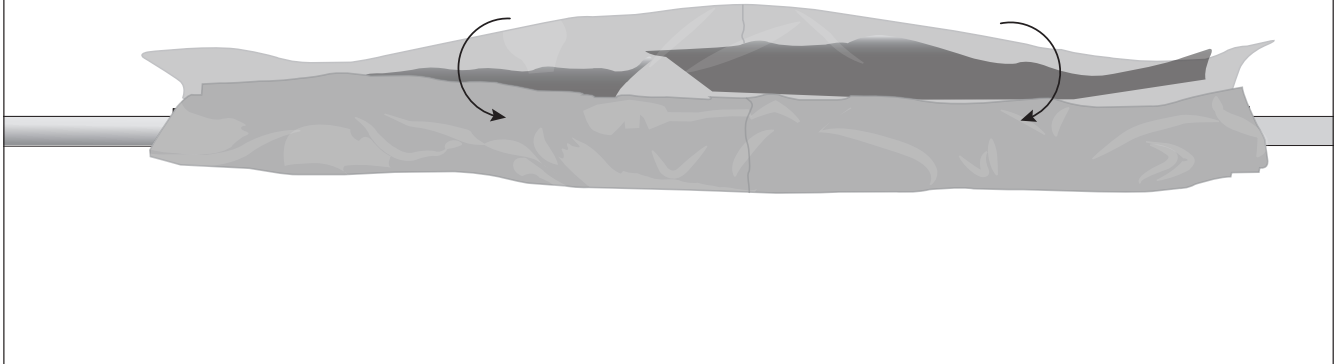

39

- Ensure that the inside and outside of the conduit end inside the concrete form are deburred.
- Position the power connection and power cable such that there is between 1 and 6 inches of power cable visible between the end of the conduit and the end of the power connection heat shrink tubing.

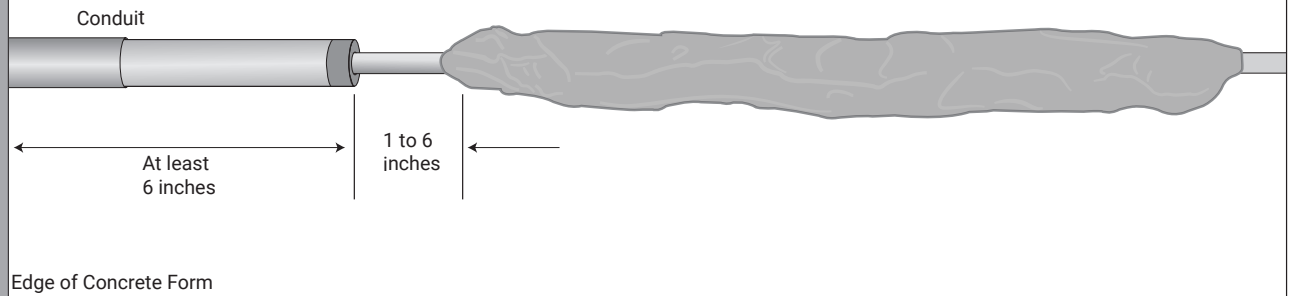

40

- Slide the 9 inch long heat shrink tubing (Item N) up from the heating, so that it evenly covers the ends of the conduit and power connection heat shrink tubing.
- Shrink the tubing evenly starting in the middle and working toward both ends.
- Ensure that both ends are fully recovered.

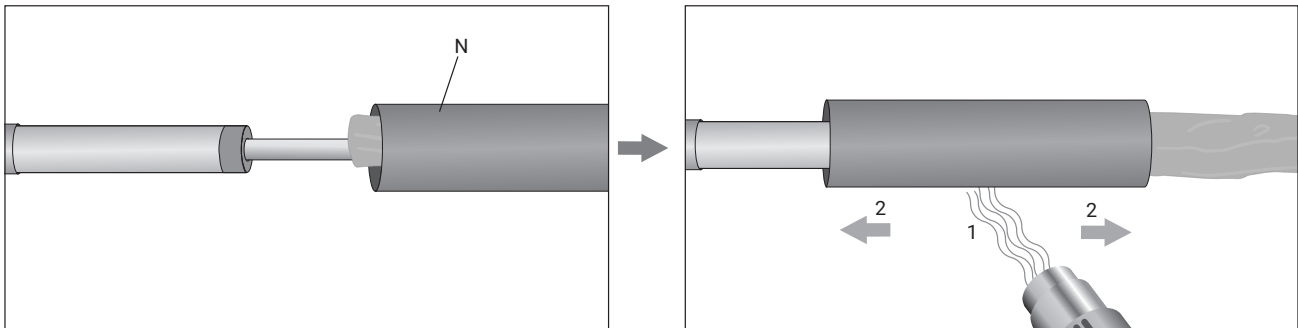

- Completed power connection sealed to conduit



EMK-XC-USA END SEAL INSTRUCTIONS

1

⚠ WARNING: Do not cut into inner jacket. This could result in a short circuit.

- Score along and around heating cable jacket to indicated dimensions.

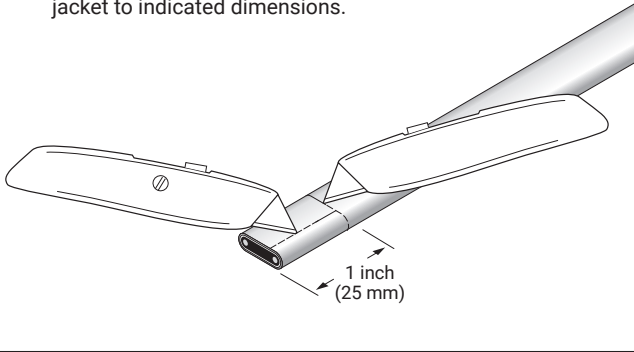

2

- **Gently** heat as described in power connection step 1.
- Roll outer jacket back around heating cable to remove.
- See power connection step 6 for detailed method.

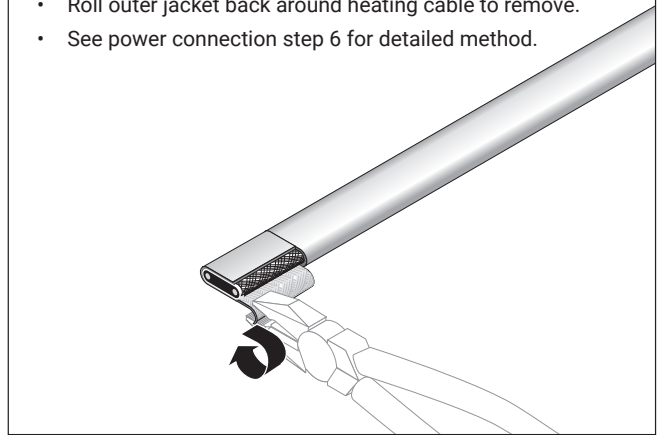

3

- Untangle braid and closely trim braid flush with end of cables' outer jacket.
- Ensure no remaining braid wire fragments.
- Be careful to not damage inner jacket.

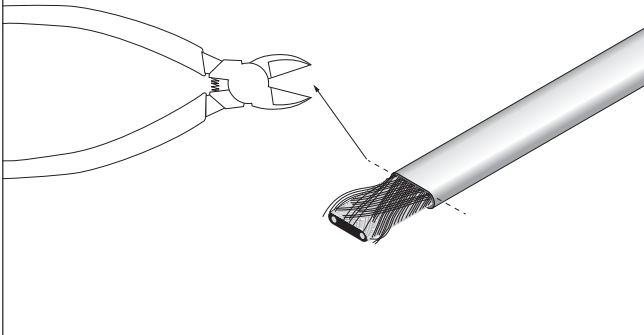

4

- Rub away loose or tall jacket fragments to ensure cap seals on surface.
- Low profile and smooth jacket remnants may be left attached.
- Trim wires very closely to body; wires cannot poke up through mastic.

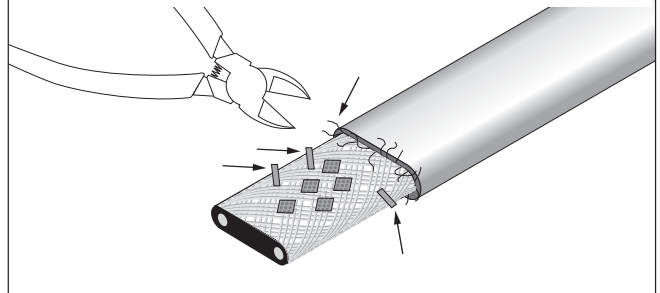

5

- Slide heat shrinkable tube (Item J) onto heating cable.

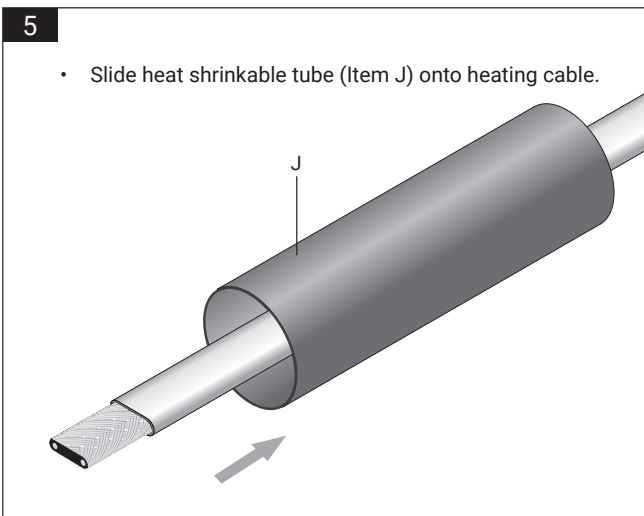

6

- Insert heat shrinkable cap (Item M) over tip of cable.

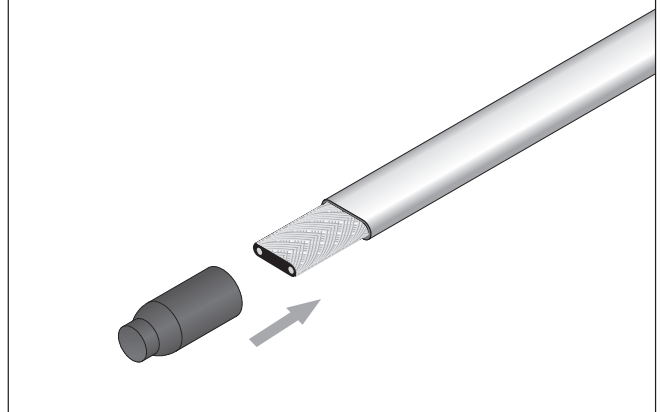

7

- Shrink heat shrinkable cap (Item M) over tip of cable to form seal.
- Ensure cap is fully shrunk and remains entirely on cable.

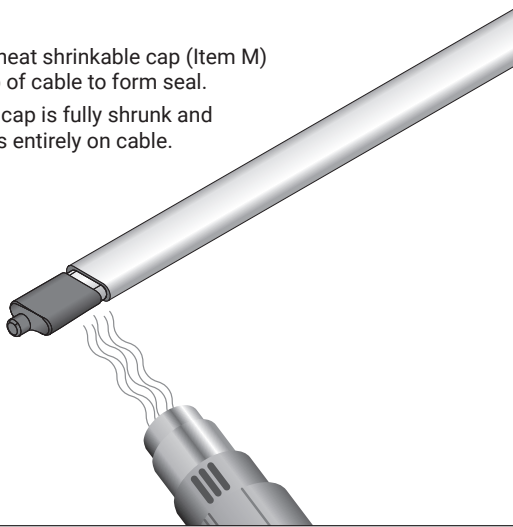

8

- Wrap mastic (Item E) across cable core to outer jacket interface.
- Wrap body of cable with two strips as indicated.

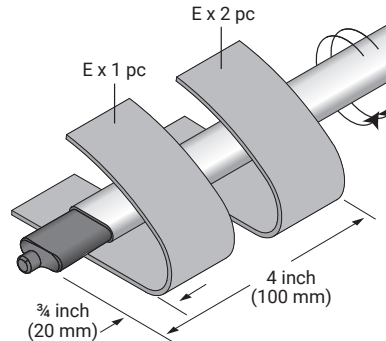

9

- Insert cable with mastic bands (Item E) into end seal (Item K) opening allowing mastic to form a seal at the interface.

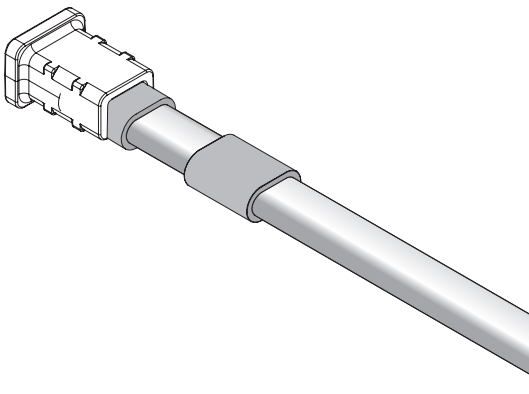

10

- Pack excess mastic (Item E) to form fillet at end plug entrance sealing cable body to end plug at opening.
- Wrap additional mastic band half across the end plug (Item K) and cable/mastic fillet at end plug opening.

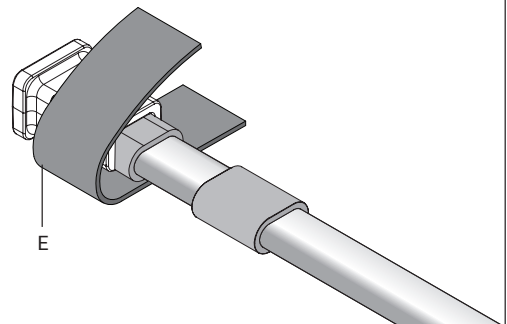

11

- Squeeze and slide heat shrinkable tube (Item J) up to flange shoulder of end seal plug.
- Tube should not cover outer rim of end seal plug.

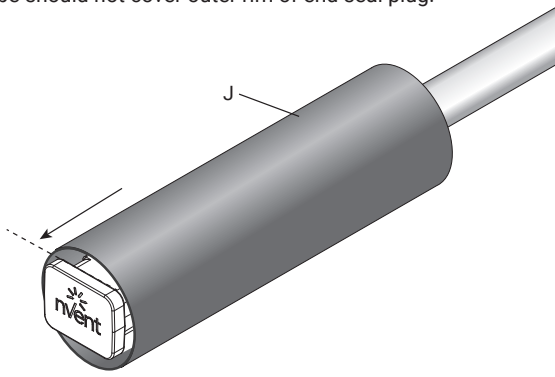

12

- Shrink tube (Item J) starting at plug side and completing at cable side.
- Ensure that tubing shrinks completely over its full length.

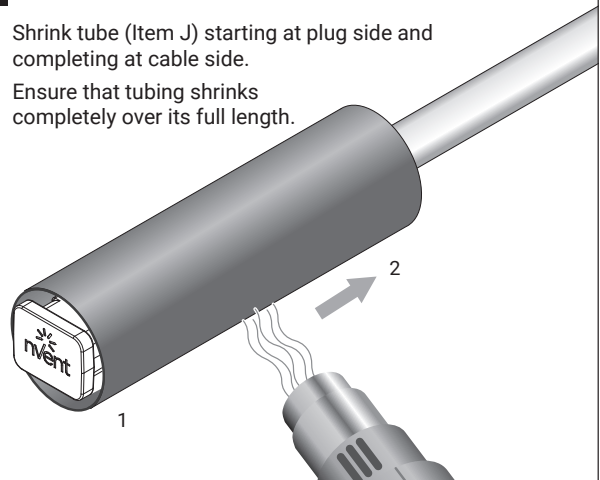

13

- Overlap the 2 pieces of aluminum tapes (Item P) by ¼ inch widthwise



14

- Line the tip of the end seal plug 1" away from the edge of the tapes.

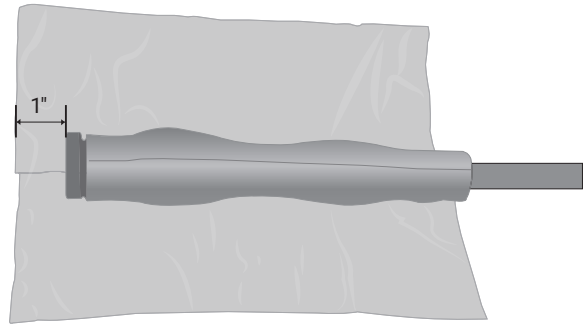

15

- Press and form the aluminium tapes onto the heat shrink tube and the end seal plug. Ensure the heat shrink tube and the end seal plug are completely covered by the aluminum tapes.

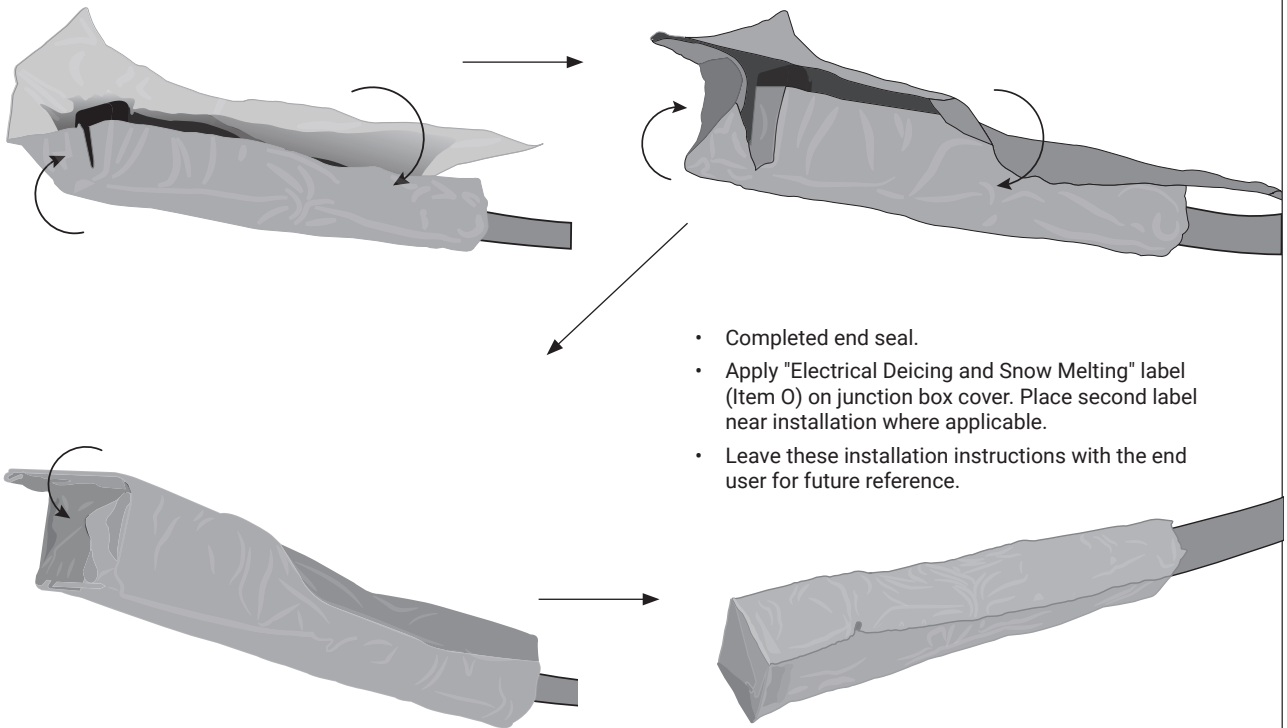

- Completed end seal.
- Apply "Electrical Deicing and Snow Melting" label (Item O) on junction box cover. Place second label near installation where applicable.
- Leave these installation instructions with the end user for future reference.

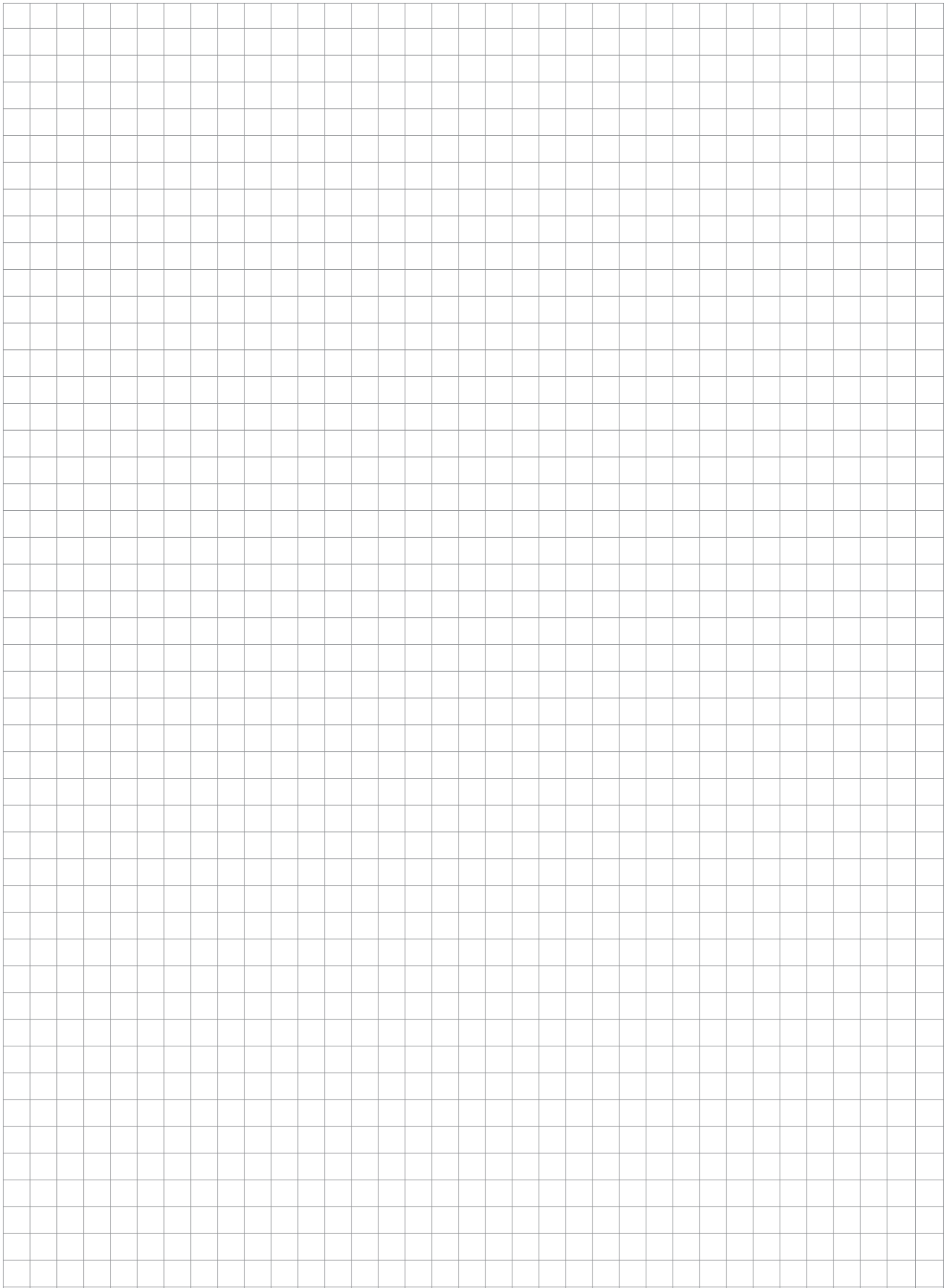

North America

Tel +1.800.545.6258
Fax +1.800.527.5703
thermal.info@nVent.com



nVent.com/RAYCHEM

©2023 nVent. All nVent marks and logos are owned or licensed by nVent Services GmbH or its affiliates. All other trademarks are the property of their respective owners.
nVent reserves the right to change specifications without notice.

RAYCHEM-IM-H61027-EMKXCUSA-EN-2311