



T-SERIES

AIR CONDITIONER

T43 MODEL

INSTRUCTION MANUAL

TABLE OF CONTENTS

WARRANTY AND RETURN POLICY	2
IMPORTANT NOTICE	2
RECEIVING THE AIR CONDITIONER.....	3
HANDLING AND TESTING THE AIR CONDITIONER.....	3
INSTALLATION INSTRUCTIONS	4
Design Data.....	4
DIMENSIONAL DRAWINGS	5
MOUNTING CUTOUT DIMENSIONS	6
MOUNTING GASKET KIT	7
Components List (115 Volt).....	8
Components List (230/460 Volt)	9
Wiring Diagram and Schematic	10
Generic Wire Diagram 115V and 6000 BTU 230V Models (actual unit options may vary)	10
Generic Wire Diagram 8000 and 10000 BTU 230V Models (actual unit options may vary)	11
Generic Schematic For 115V and 6000 BTU 230V Models (actual unit options may vary)	12
Generic Schematic For 8000 and 10000 BTU 230V Models (actual unit options may vary).....	13
Generic Wire Diagram For 3-Phase Models (actual unit options may vary).....	14
TEMPERATURE CONTROL	15
Units With Heat	15
PRINCIPLES OF OPERATION	15
MAINTENANCE.....	15
Compressor.....	15
Inlet Air Filter	15
How To Remove, Clean or Install a New Inlet Air Filter	16
Condenser and Evaporator Air Movers.....	16
Refrigerant Loss.....	16
TROUBLE SHOOTING	18
Basic Air Conditioning Trouble Shooting Check List.....	18
Symptoms and Possible Causes:	19
F-GAS INFORMATION.....	19

NOTE: Some of the information in this manual may not apply if a special unit was ordered. If additional drawings for a special unit are necessary, they have been inserted. Contact nVent Equipment Protection if further information is required.

WARRANTY AND RETURN POLICY

<https://hoffman.nvent.com/en/hoffman/warranty-information>

IMPORTANT NOTICE

- These instructions were authored in English. Instructions published in languages other than English have been translated from the authored language.
- These air conditioners are intended to be used by properly trained customers in industrial, communications and agricultural environments.
- Operating sound level is below 70 dBA.



RECEIVING THE AIR CONDITIONER

Inspect the air conditioner. Check for concealed damage that may have occurred during shipment. Look for dents, scratches, loose assemblies, evidence of oil, etc. Damage evident upon receipt should be noted on the freight bill. Damage should be brought to the attention of the delivering carrier – NOT to nVent Equipment Protection – within 15 days of delivery. Save the carton and packing material and request an inspection. Then file a claim with the delivering carrier.

nVent Equipment Protection cannot accept responsibility for freight damages; however, we will assist you in any way possible.

HANDLING AND TESTING THE AIR CONDITIONER

If the air conditioner has been in a horizontal position, be certain it is placed in an upright, vertical or mounting position for a minimum of five (5) minutes before operating.

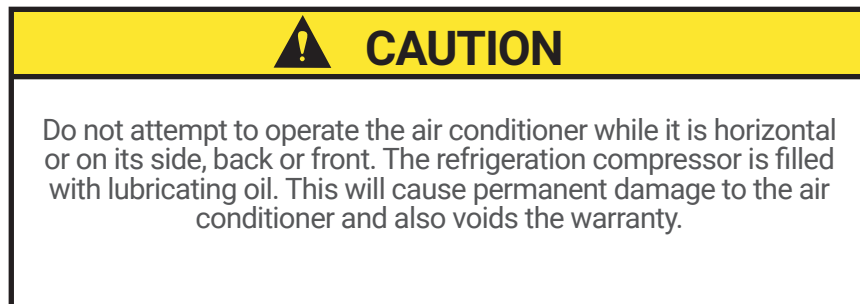

TEST FOR FUNCTIONALITY BEFORE MOUNTING THE AIR CONDITIONER TO THE ENCLOSURE.

Refer to the nameplate for proper electrical current requirements, and then connect the power cord to a properly grounded power supply. Minimum circuit ampacity should be at least 125% of the amperage shown in the design data section for the appropriate model. No other equipment should be connected to this circuit to prevent overloading.

Operate the air conditioner for five (5) to ten (10) minutes. No excessive noise or vibration should be evident during this run period. The condenser blower (ambient air), the evaporator impeller (enclosure air), and the compressor should be running.

Condenser air temperatures should be warmer than normal room temperatures within a few minutes. The compressor is provided with automatic reset thermal overload protection. This thermoswitch is located and mounted inside the plastic enclosure clipped to the compressor. The switch operates when the compressor overheats due to clogged or dirty inlet air filter or if ambient air temperatures exceed nameplate rating or if enclosure dissipated heat loads exceed the rated capacity of the air conditioner. The thermal overload switch will actuate and stop compressor operation. The blowers will continue to operate and the compressor will restart after it has cooled to within the thermal overload cut-in temperature setting.

INSTALLATION INSTRUCTIONS

1. Inspect the air conditioner and verify correct functionality before mounting the air conditioner. See HANDLING AND TESTING THE AIR CONDITIONER on page 3.
2. Using the cutout dimensions, See MOUNTING CUTOUT DIMENSIONS on page 6 in this manual, prepare the air "IN" and air "OUT" openings, and mounting bolt hole pattern for the enclosure.
3. Using the gasket kit provided, install gaskets to air conditioner. See MOUNTING GASKET KIT on page 7 for proper location.
4. Mount air conditioner on enclosure using mounting bolts and screws provided. "EZ" mount tabs can be used to hold unit on enclosure while mounting in place. Allow unit to remain upright for a minimum of five (5) minutes before starting. Caution! Air conditioner must be in upright position during operation.
5. To avoid cross-threading mounting inserts, start bolts by hand before tightening with a wrench or ratchet driver.
6. When routing the drain tube, caution should be taken to keep it from kinking or being elevated above the exit point of the air conditioner. The drain tube must be on a continuous downward slope. A slight elevation of the tube could result in secondary trap. FAILURE TO FOLLOW THESE INSTRUCTIONS COULD RESULT IN OVERFLOWING OF THE CONDENSATE DRAIN PAN.
7. Refer to top of nameplate for electrical requirements. Connect the power cord to a properly grounded power supply. Use of an extension cord is not recommended. Electrical circuit should be fused with slow blow or HACR circuit breaker.

DESIGN DATA

Model	Voltage	Hz	Full Load Amps	Phase	BTU/Hr @ Max Amb Temp	Max Amb Temp °F/°C	Shipping Weight lb./kg
T430616GXXX	115	50/60	7.9	1	6080/6300	131/55	125/57
T430626GXXX	230	50/60	4.2	1	6400/6600	131/55	125/57
T430816GXXX	115	50/60	9.8/11.2	1	7400/8100	131/55	125/57
T430826GXXX	230	50/60	4.9/6.2	1	7600/8200	131/55	125/57
T431016GXXX	115	50/60	16.2/21.0	1	10090/11090	131/55	125/57
T431026GXXX	230	50/60	7.8/9.5	1	9750/10250	131/55	125/57
T431046GXXX	460	50/60	5.5	1	9750/10250	131/55	150/68
T431046G4XX	400/460	50/60	3.1/3.4	3	8970/9600	131/55	140/64

XXX will be replaced with a three-digit number designating all desired options. Consult the factory for specific model numbers.

DIMENSIONAL DRAWINGS

6K BTU

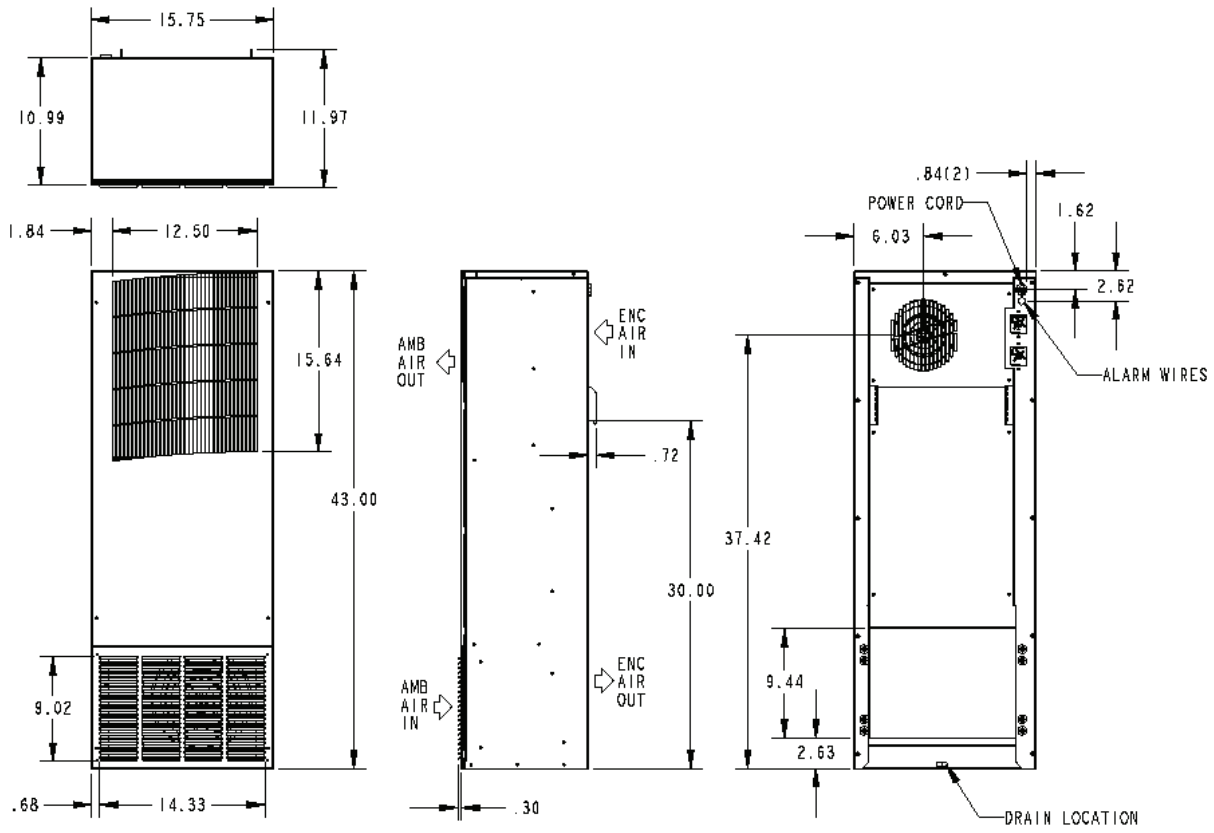

8-10K BTU

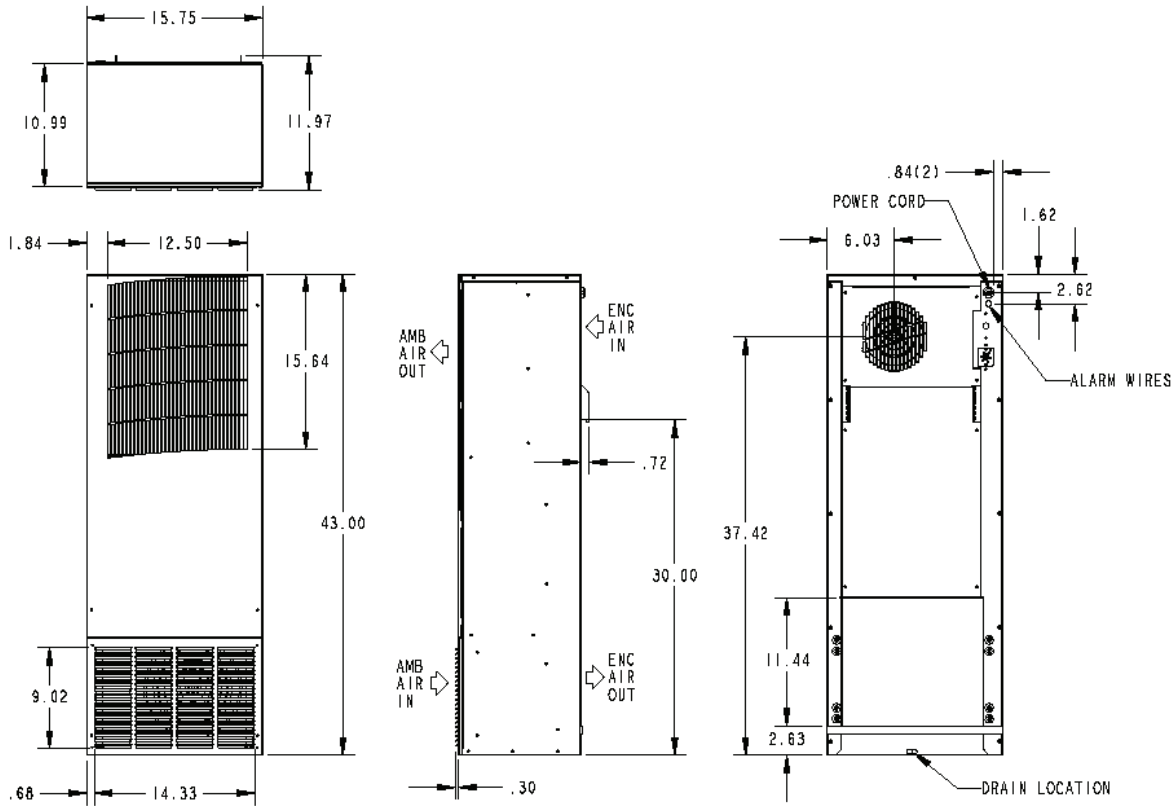

MOUNTING CUTOUT DIMENSIONS

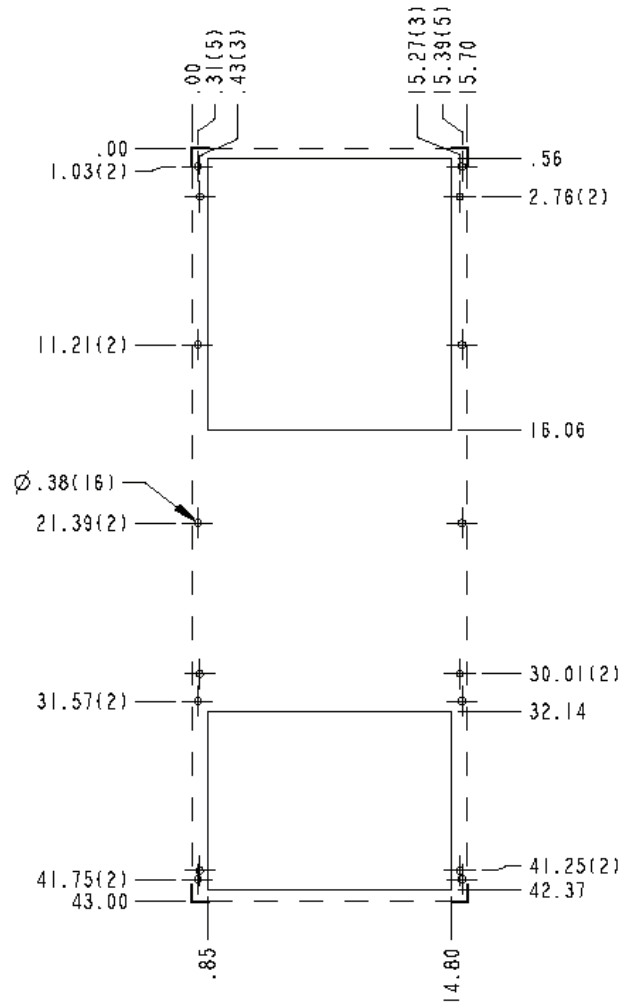
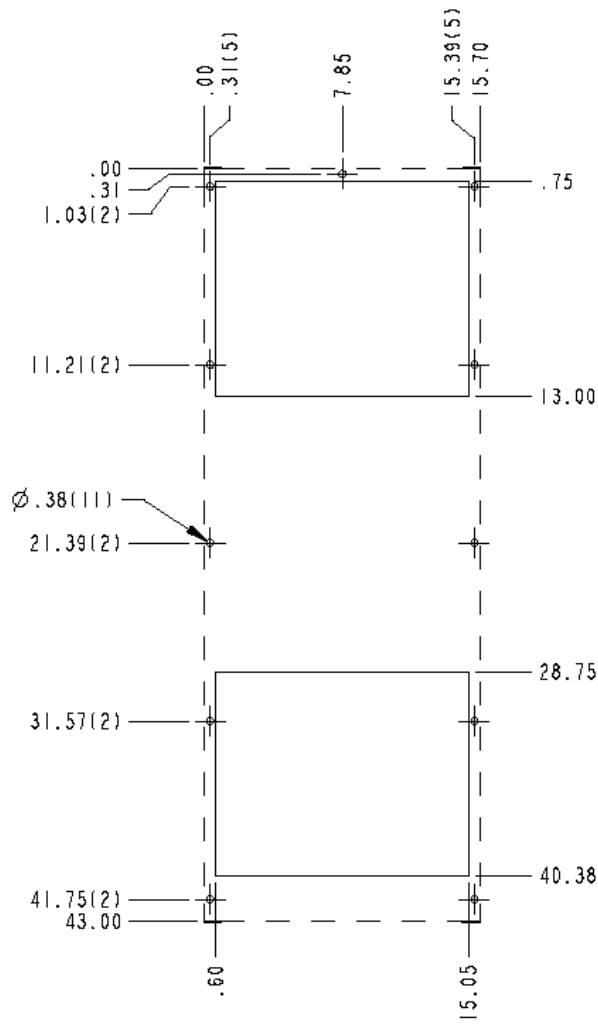

MOUNTING GASKET KIT

MOUNTING GASKET KIT, 45-1000-50 INCLUDED.
APPLY GASKET TO AIR CONDITIONER BEFORE
MOUNTING TO ENCLOSURE

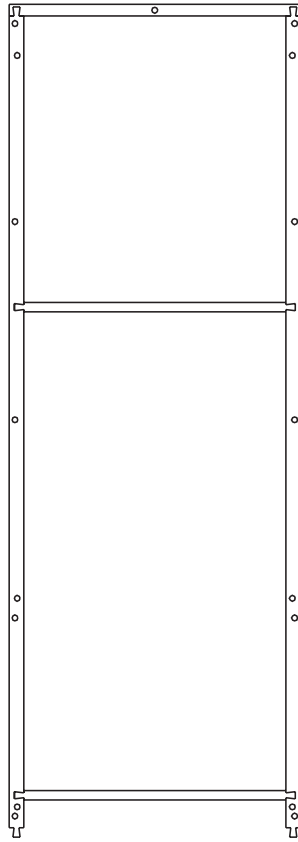

EXTERNAL MOUNT
(EVAP SIDE)

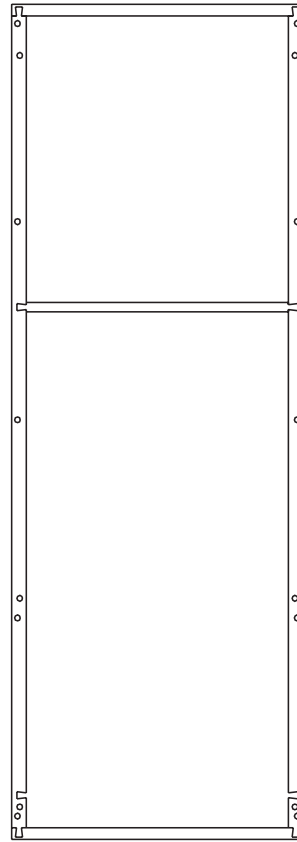

INTERNAL MOUNT
(COND SIDE)

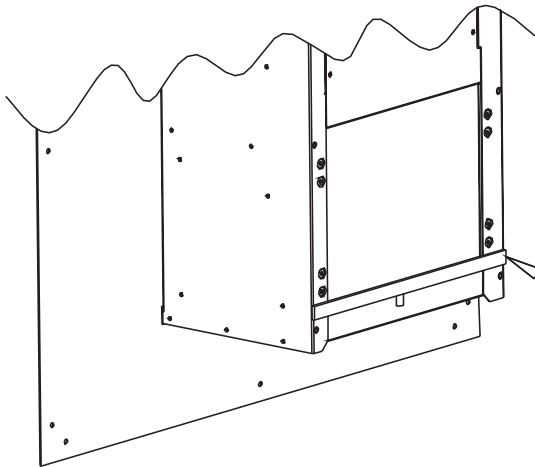

NOTE:
ADD STRIP TO
EVAP PAN IF
INTERNALLY MOUNTED
(INCLUDED)

COMPONENTS LIST (115 VOLT)

Item	Part Description	Part Number		
		6000 BTU	8000 BTU	10000 BTU
1	Capacitor, Compressor, Start	89173376	89115350	10-1032-08
2	Capacitor, Compressor, Run	89172425	89172425	89172481
3	Capacitor, Impeller, Condenser	52-6084-01	52-6031-03	52-6031-03
4	Capacitor, Impeller, Evaporator	52-6084-01	52-6084-01	52-6084-01
5	Coil, Condenser	45-6051-00	45-6051-00	45-6051-00
6	Coil, Evaporator	43-6025-00	43-6025-00	43-6025-00
7	Compressor	89169165	89169167	89169173
8	Filter, Air, Reusable	89057617	89057617	89057617
9	Filter/Dryer	52-6028-00	52-6028-00	52-6028-00
10	Freeze Stat	89097855	89097855	89097855
11	Head Pressure Control Switch	52-6104-26	52-6104-26	52-6104-26
12	Impeller, Condenser	10-1091-123	10-1091-138	10-1091-89
13	Impeller, Evaporator	10-1091-123	10-1091-123	10-1091-123
14	Relay, Compressor Start	89172340	89172340	89172341
15	Service Cord	89107626	89107626	52-6035-85
16	Thermal Expansion Valve	99-0540-39 (cap tube)	10-1040-37	10-1040-38
17	Thermal Overload, Compressor	89183837	89183472	Internal
18	Thermostat, SPST, 55-100F	10-1061-16	10-1061-16	10-1061-16

T43 115V MODELS T43 6,000 BTU 230/460V MODELS

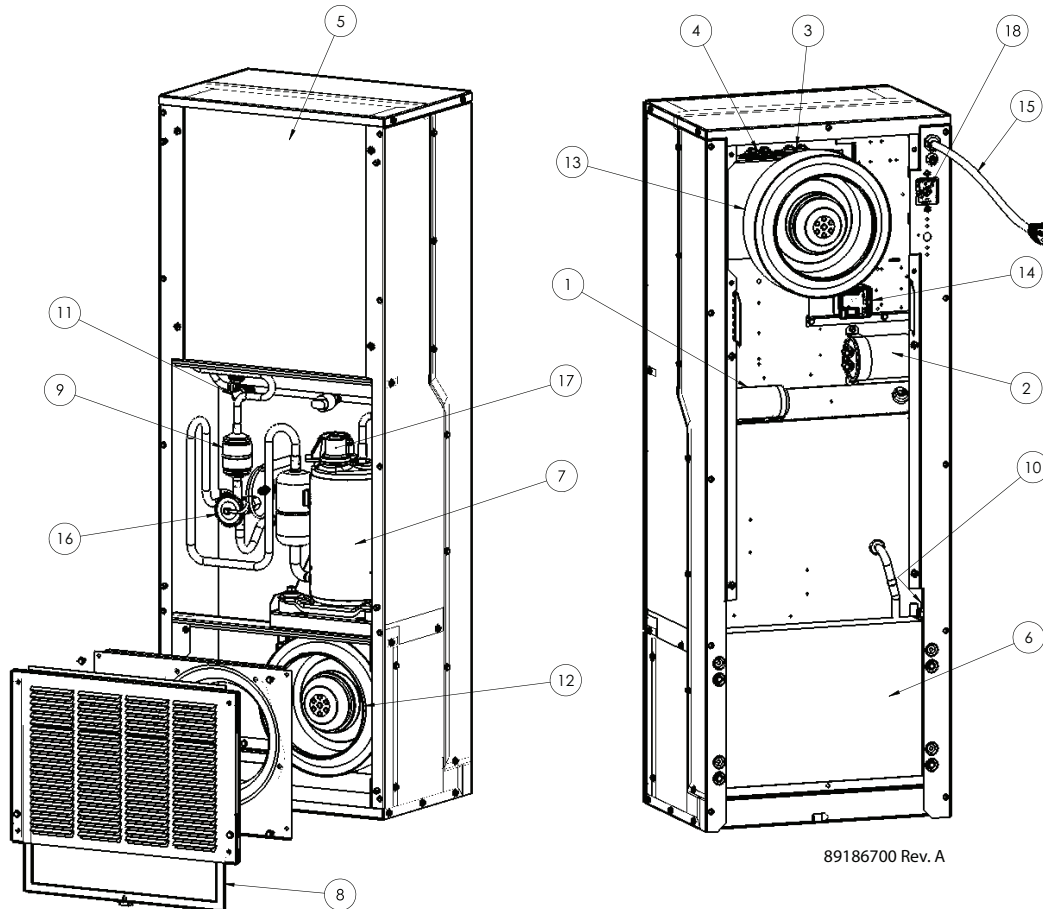

COMPONENTS LIST (230/460 VOLT)

Item	Part Description	Part Number			460V 3-Phase
		6000 BTU	8000 BTU	10000 BTU	10000 BTU
1	Capacitor, Compressor, Start	10-1032-08	N/A	N/A	N/A
2	Capacitor, Compressor, Run	89104097	89174772	89174771	N/A
3	Capacitor, Impeller, Condenser	52-6084-02	52-6084-02	52-6084-05	52-6032-20
4	Capacitor, Impeller, Evaporator	52-6084-02	52-6084-02	52-6084-02	52-6032-14
5	Coil, Condenser	45-6051-00	45-6051-00	45-6051-00	45-6051-00
6	Coil, Evaporator	43-6025-00	45-6050-00	45-6050-00	45-6050-00
7	Compressor	89169166	89105607	89107889	89107890
8	Filter, Air, Reusable	89057617	89057617	89057617	89057617
9	Filter/Dryer	52-6028-00	52-6028-00	52-6028-00	52-6028-00
10	Freeze Stat	89097855	89097855	89097855	87097855
11	Head Pressure Control Switch	52-6104-26	52-6104-26	52-6104-26	52-6104-26
12	Impeller, Condenser	10-1091-124	10-1091-124	10-1091-90	10-1091-90
13	Impeller, Evaporator	10-1091-124	10-1091-124	10-1091-124	10-1091-124
14	Relay, Compressor Start or Time Delay	89172340	89172089	89172089	N/A
15	Service Cord	52-6035-32	52-6035-32	52-6035-32	N/A
16	Thermal Expansion Valve	99-0540-39 (cap tube)	10-1040-42	10-1040-38	10-1040-31
17	Thermal Overload, Compressor	TTC=8300MRAL20 OR TI=MRA4765-114	TTC=8300MRAL23 OR TI=MRA1706-114	Internal	89171728
18	Thermostat, SPST, 55-100F	10-1061-16	10-1061-16	10-1061-16	10-1061-16
19	Relay, Phase Monitor	N/A	N/A	N/A	89117576
20	Relay, Overload	N/A	N/A	N/A	89098326
21	Contact, 3-Pole	N/A	N/A	N/A	89102057
22	Relay, 24 VAC	N/A	N/A	N/A	10-1005-36
23	Transformer, 460/230V, 400VA	N/A	N/A	N/A	10-1006-128
24	Transformer, 230-208/24V, 20VA	N/A	N/A	N/A	89154383

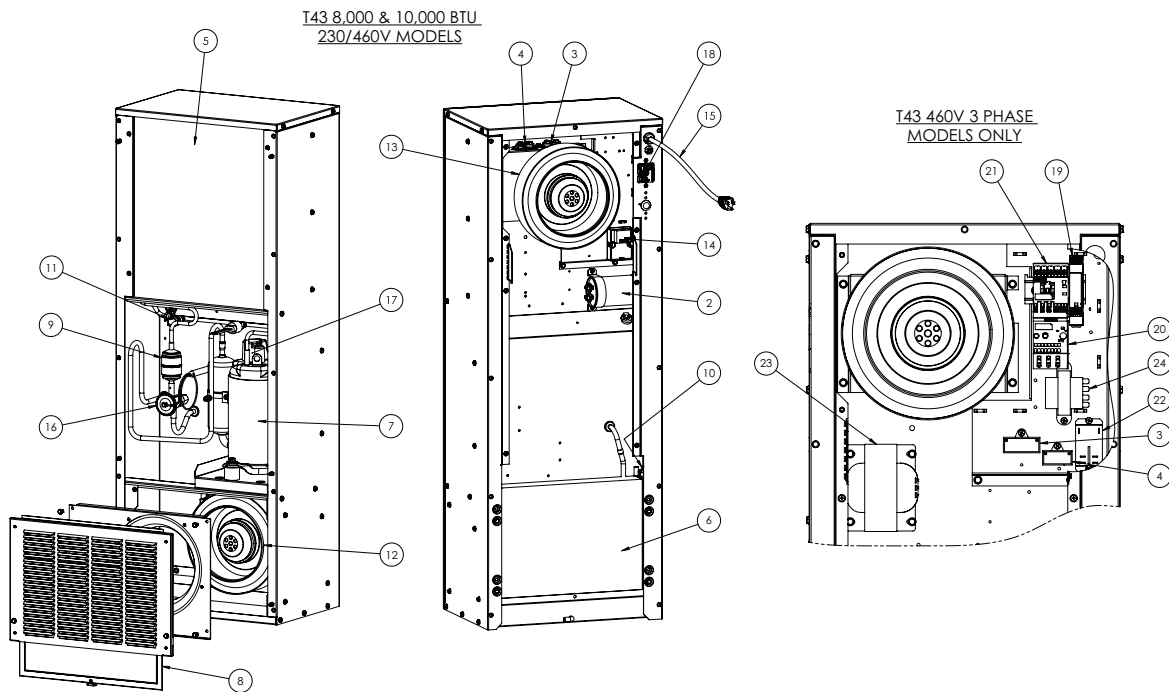

WIRING DIAGRAM AND SCHEMATIC

GENERIC WIRE DIAGRAM 115V AND 6000 BTU 230V MODELS (ACTUAL UNIT OPTIONS MAY VARY)

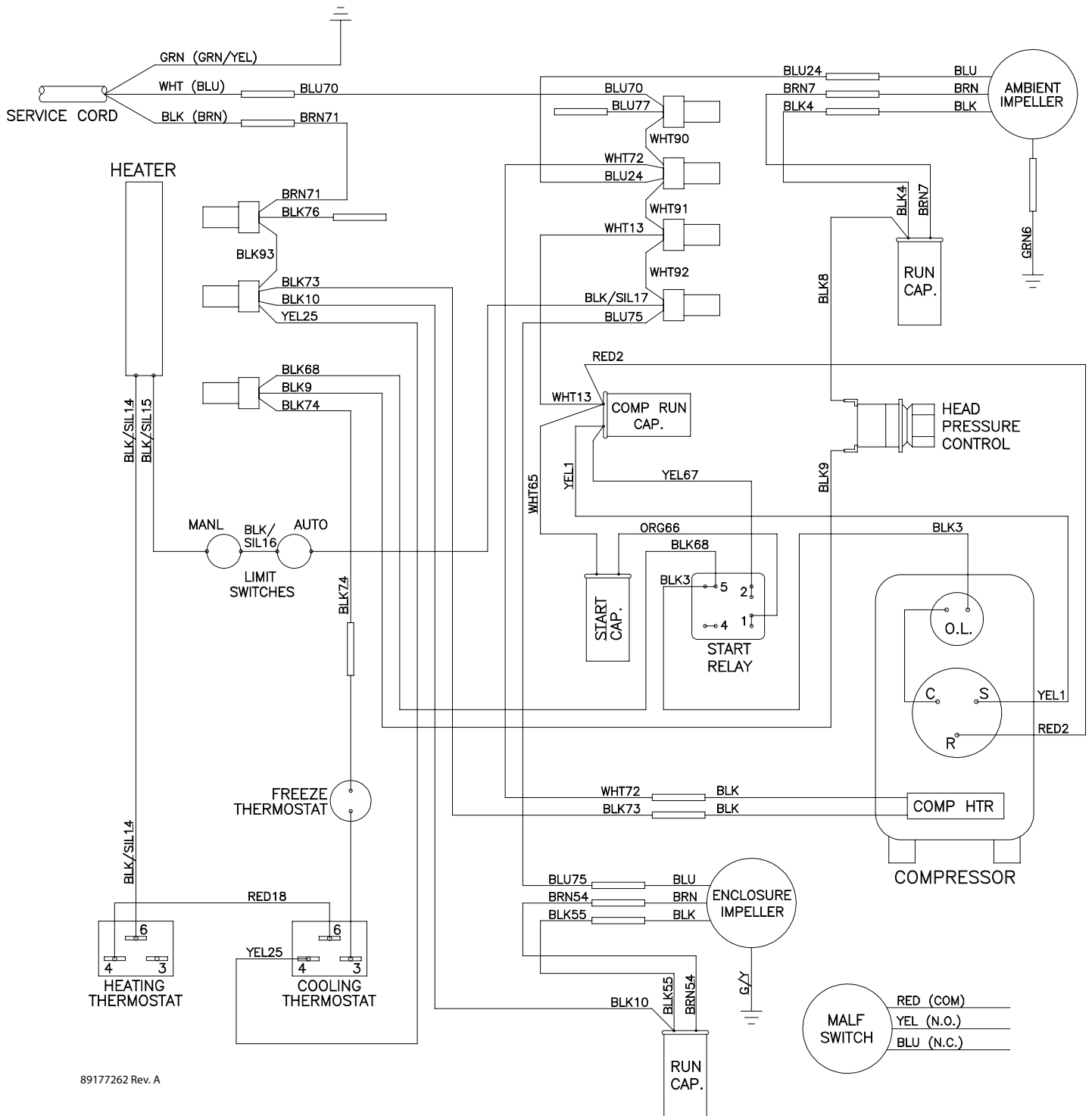

89177262 Rev. A

GENERIC WIRE DIAGRAM 8000 AND 10000 BTU 230V MODELS (ACTUAL UNIT OPTIONS MAY VARY)

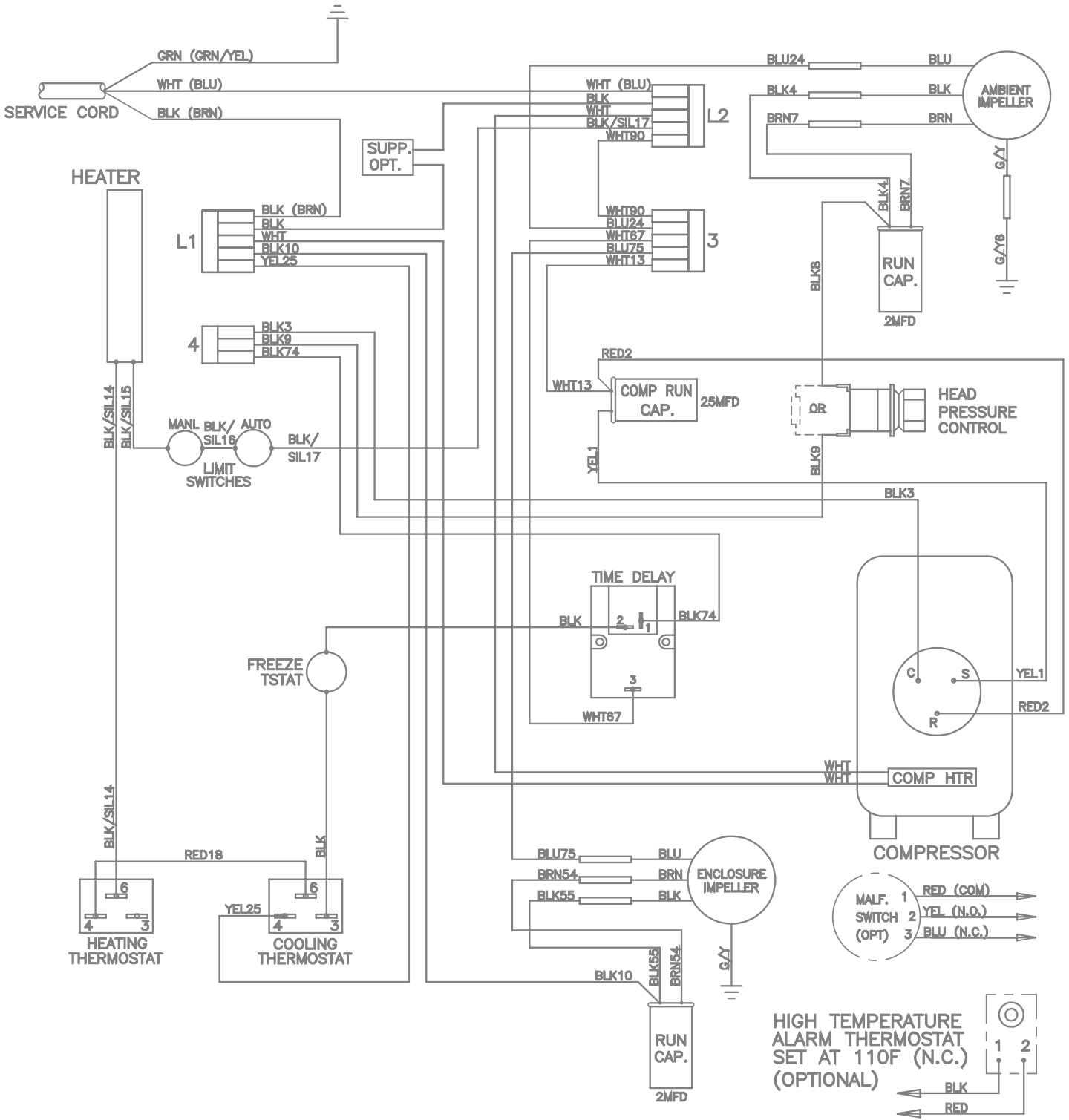

GENERIC SCHEMATIC FOR 115V AND 6000 BTU 230V MODELS (ACTUAL UNIT OPTIONS MAY VARY)

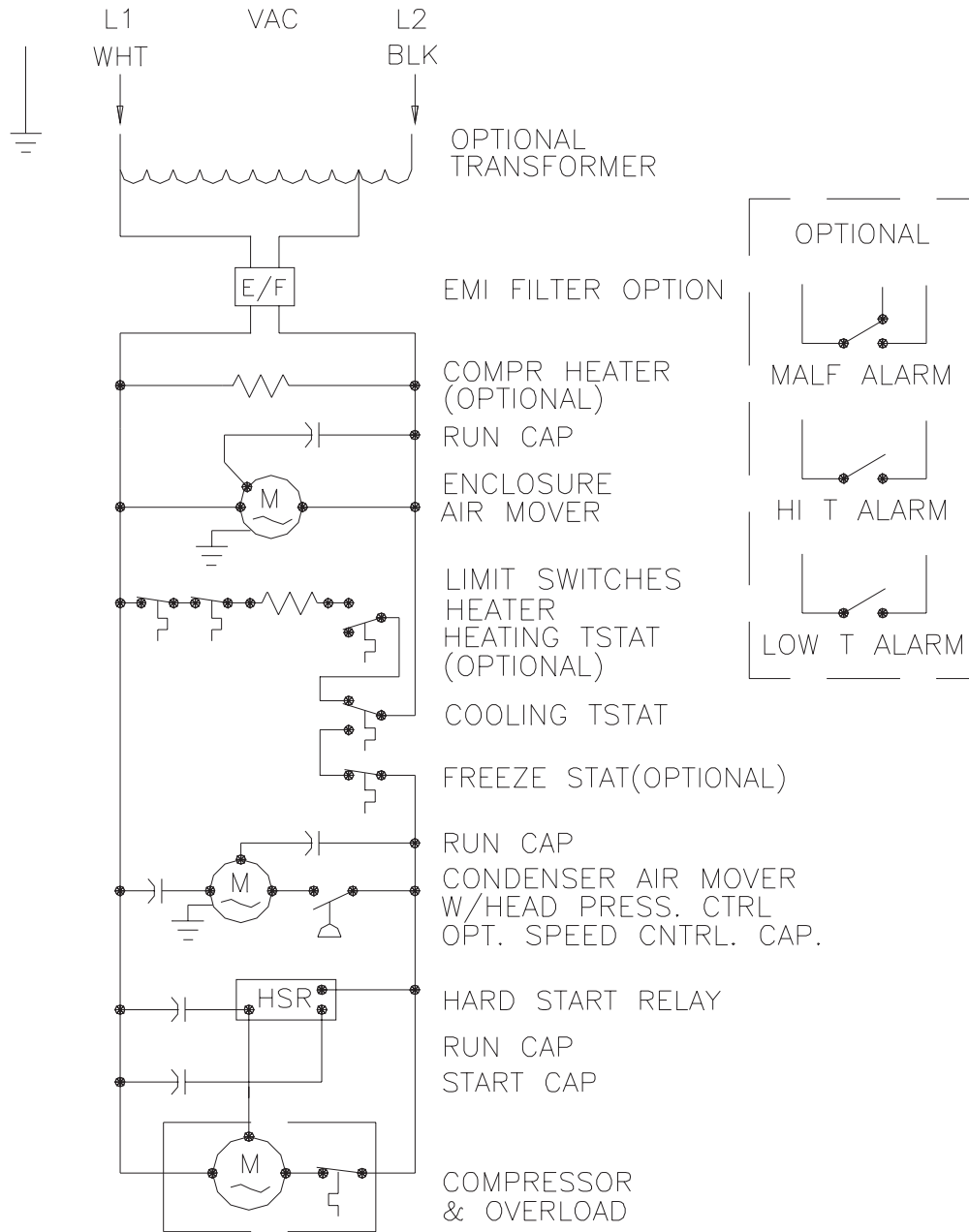

GENERIC SCHEMATIC FOR 8000 AND 10000 BTU 230V MODELS (ACTUAL UNIT OPTIONS MAY VARY)

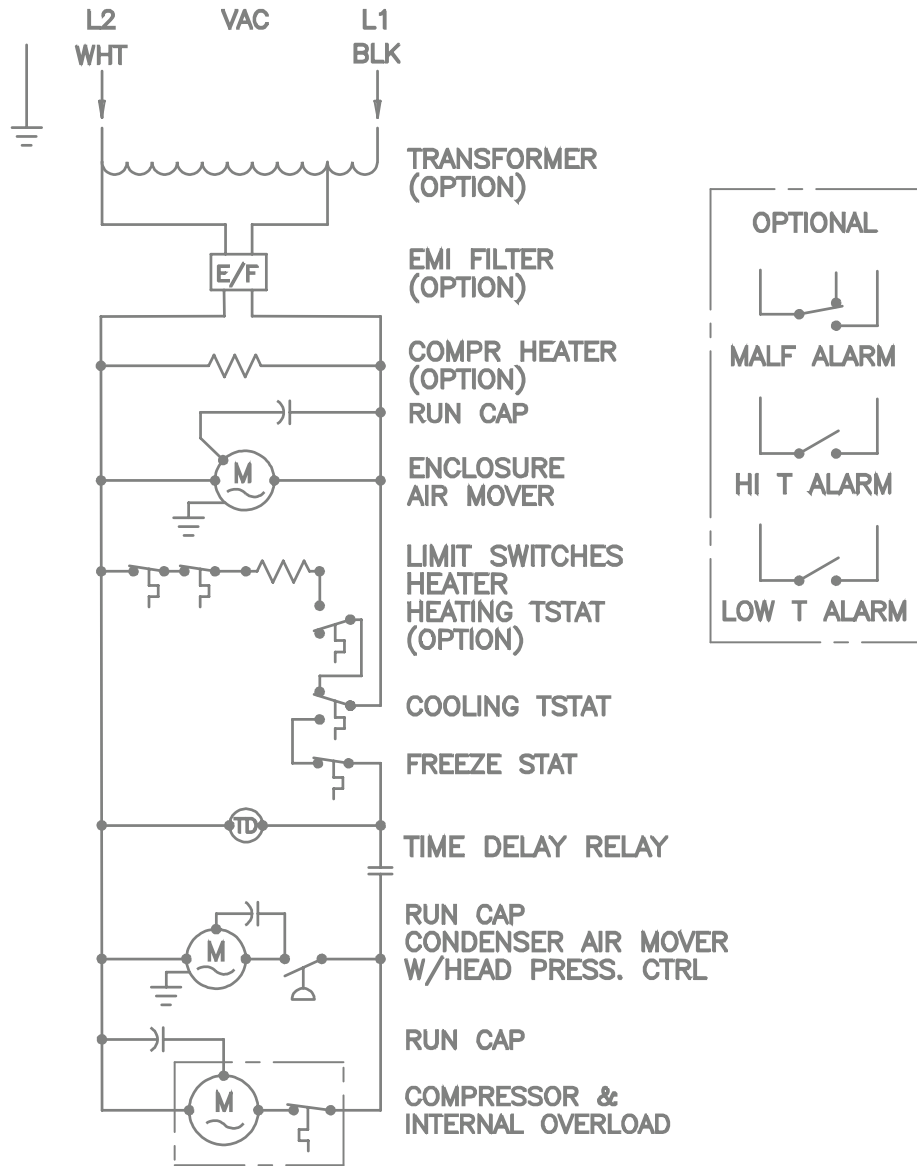

ELECTRICAL SCHEMATIC

89168160 REV.B

GENERIC WIRE DIAGRAM FOR 3-PHASE MODELS (ACTUAL UNIT OPTIONS MAY VARY)

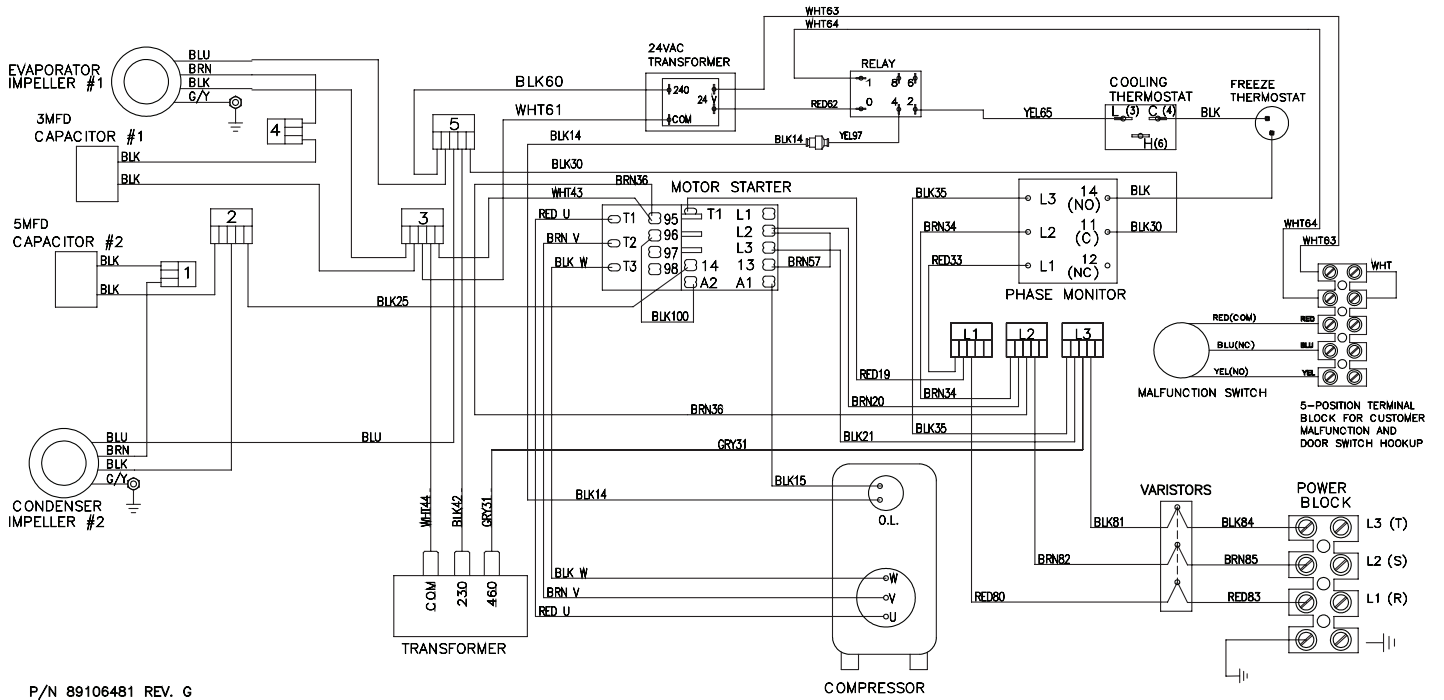

P/N 89106481 REV. G

TEMPERATURE CONTROL

The electromechanical thermostat is factory preset to 75 F/24 C. To change the temperature setting, remove the nylon plug (if applicable) from the back face of the unit. Use a standard screwdriver to adjust thermostat. For cooler temperatures turn clockwise, for warmer temperatures turn counterclockwise. The set point of the thermostat equals the off temperature. The on temperature is 10 F/5 C above the set point.

UNITS WITH HEAT

The heating thermostat is factory preset to 55 F/13 C. The set point for the heating thermostat equals the on temperature. The off temperature is 10 F/5 C above the set point.

PRINCIPLES OF OPERATION

If electrical power to the air conditioner is interrupted and reapplied immediately, (within 3 to 5 seconds), the compressor may not restart due to the high back pressure of the compressor. It takes a minimum of one (1) minute after shut-down for the compressor suction and discharge pressures to equalize in order for the air conditioner to restart.

Operating the air conditioner below the minimum ambient temperature or above the maximum ambient temperatures indicated on the nameplate voids all warranties.

It is recommended that the warranty section of this manual be read in order to familiarize yourself with parameters of restricted operation.

The moisture that the enclosure air can contain is limited. If moisture flows from the drain tube continuously this can only mean that ambient air is entering the enclosure. Be aware that frequent opening of the enclosure's door admits humid air, which the air conditioner must then dehumidify.

MAINTENANCE

COMPRESSOR

The compressor requires no maintenance. It is hermetically sealed, properly lubricated at the factory and should provide years of satisfactory operating service.

Should the refrigerant charge be lost, recharging ports (access fittings) on the suction and discharge sides of the compressor are provided for recharging and/or checking suction and discharge pressures.

Under no circumstances should the access fitting covers be loosened, removed or tampered with.

Breaking of seals on compressor access fittings during warranty period will void warranty on hermetic system.

Recharging ports are provided for the ease and convenience of reputable refrigeration repair service personnel for recharging the air conditioner.

INLET AIR FILTER

Proper maintenance of the inlet air filter, located behind the front cover, will assure normal operation of the air conditioner. If filter maintenance is delayed or ignored, the maximum ambient temperatures under which the unit is designed to operate will be decreased.

If the compressor's operating temperature increases above designed conditions due to a dirty or clogged filter (or plugged condenser coil), the air conditioner's compressor will stop operating due to actuation of the thermal overload cut-out switch located on the compressor housing. As soon as the compressor temperature has dropped to within the switch's cut-in setting, the compressor will restart automatically. However the above condition will continue to take place until the filter or coil has been cleaned. It is recommended that power to the air conditioner be interrupted intentionally when abnormally high compressor operating temperature causes automatic shut-down of the unit. The above described shut-down is symptomatic of a clogged or dirty filter, thus causing a reduction in cooling air flow across the surface of the compressor and condenser coil.

Do not run the air conditioner for extended periods of time with the filter removed. Particles of dust, lint, etc., can plug the fins of the condenser coil which will give the same reaction as a plugged filter. The condenser coil is not visible through the filter opening, so protect it with a filter.

Continued operation under the above conditions can and will damage and shorten compressor life. The air conditioner is available with an easily removable inlet filter to facilitate necessary cleaning. There should be no reason to neglect this necessary maintenance.

HOW TO REMOVE, CLEAN OR INSTALL A NEW INLET AIR FILTER

RP aluminum washable air filters are designed to provide excellent filtering efficiency with a high dust holding capacity and a minimum amount of resistance to air flow. Because they are constructed entirely of aluminum they are lightweight and easy to service. Optimum filter performance is maintained by recoating the filters after washing with RP Super Filter Coat adhesive. To achieve maximum performance from your air handling equipment, air filters should be cleaned on a regular basis.

The inlet air filter is located behind the lower access cover. To access filter, pull ring protruding from slot in bottom of front cover, or remove the lower access cover by removing the two screws at the bottom of unit, the filter is held in the cover, slide filter out. The filter may now be cleaned or new filter installed.

Cleaning Instructions:

1. Flush the filter with warm water from the exhaust side to the intake side. **DO NOT USE CAUSTICS.**
2. After flushing, allow filter to drain. Placing it with a corner down will assure complete drainage.
3. Recoat the filters with RP Super Filter Coat adhesive. When spraying filter do so from both sides for maximum concentration of adhesive.

CONDENSER AND EVAPORATOR AIR MOVERS

Impeller motors require no maintenance. All bearings, shafts, etc. are lubricated during manufacturing for the life of the motor.

If the condenser impeller motor (ambient impeller) should fail, it is not necessary to remove the air conditioner from the cabinet or enclosure to replace the blower. The condenser blower is mounted on its own bulkhead and is easily accessible by removing the lower access panel.

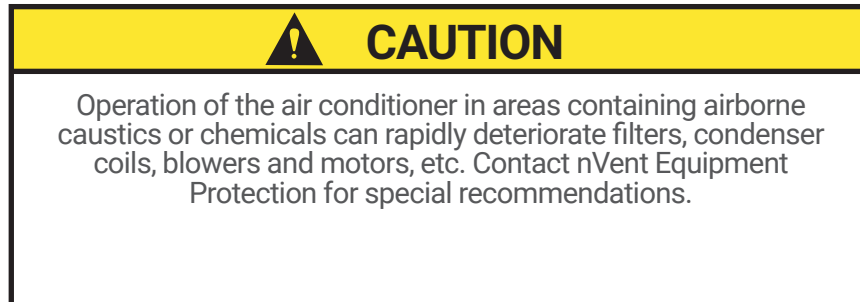

REFRIGERANT LOSS

Each air conditioner is thoroughly tested prior to leaving the factory to insure against refrigeration leaks. Shipping damage or microscopic leaks not found with sensitive electronic refrigerant leak detection equipment during manufacture may require repair or recharging of the system. This work should only be performed by qualified professionals, generally available through a local, reputable air conditioning repair or service company.

Refer to the data on the nameplate which specifies the type of refrigerant and the charge size in ounces.

Before recharging, make sure there are no leaks and that the system has been properly evacuated into a deep vacuum.

NOTES

TROUBLE SHOOTING

BASIC AIR CONDITIONING TROUBLE SHOOTING CHECK LIST

1. Check manufacturer's nameplate located on the unit for correct power supply.
2. Turn on power to the unit. The evaporator (Enclosure or "COLD" air) impeller should come on. Is there airflow?

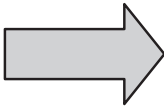
YES, proceed to step 3.	
NO, possible problem:	
<ul style="list-style-type: none">• Open motor winding• Stuck impeller motor• Obstructed wheel	
Repair or Replace defective part	

3. Check thermostat setting and adjust thermostat to the lowest setting. This should turn on the condenser impellers and compressor. Did condenser impellers and compressor come on when the thermostat was turned on?

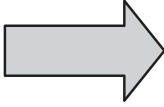
YES, proceed to step 4.	
NO, possible problem:	
<ul style="list-style-type: none">• Defective thermostat	
Replace Part	

4. Are both impellers and the compressor running? If not the unit will not cool properly.
5. Check condenser (Ambient or "HOT" air) impellers for airflow. Is there airflow?

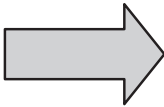
YES, proceed to step 6.	
NO, possible problem:	
<ul style="list-style-type: none">• Defective thermostat• Open motor winding• Stuck impeller motor• Obstructed wheel	
Repair or Replace defective part	

6. Carefully check the compressor for operation - motor should cause slight vibration, and the outer case of the compressor should be warm. Is the compressor showing signs of this?

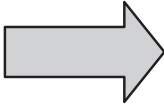
YES, wait 5 minutes, then proceed to step 7.	
NO, possible problem:	
<ul style="list-style-type: none">• Defective thermostat• Defective capacitor• Defective overload• Defective relay	
Repair or Replace defective part	

7. Make sure the coils are clean. Then check evaporator "air in" and "air out" temperatures. If the temperatures are the same:

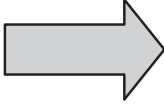
<ul style="list-style-type: none">• Possible loss of refrigerant• Possible bad valves in the compressor	
Repair or Replace defective part	

8. To check for a bad thermostat, turn power to the unit off. Remove the control box cover and place both thermostat wires onto one terminal (replace control box cover for safety). This will pass the switch in the thermostat. Turn the power on and if both blowers and the compressor come on, the thermostat needs to be replaced.

SYMPTOMS AND POSSIBLE CAUSES:

SYMPTOM	POSSIBLE CAUSE
Unit won't cool	Clogged fins on coil(s)
	Dirty filter
	Impellers not running
	Compressor not running
	Compressor runs, but has bad valves
	Loss of refrigerant
Compressor tries to start but won't run	Low line voltage at start. Should be +/-10% rated voltage.
	Compressor motor stuck
	Bad contactor
	Bad overload switch
	Bad run/start capacitor
Unit blows breakers	Undersized breaker/fuse or not time delayed
	Short in system
Getting water in enclosure	Drain plugged
	Drain tube kinked
	Enclosure not sealed (allowing humidity in)
	Mounting gasket damaged

For additional technical support (i.e., amp draw, pressures, temperatures), contact nVent Equipment Protection at 800-896-2665.

F-GAS INFORMATION

	T430616GXXX T431016GXXX	T430816GXXX	T430626GXXX T430646GXXX T430826GXXX T430846GXXX	T431026GXXX T431046GXXX 1-Ph	T431046GXXX 3-PH
Refrigerant Kühlmittel Chłodziwo	R134a	R134a	R134a	R134a	R134a
GWP	1430	1430	1430	1430	1430
Factory Charge Füllmenge durch Hersteller Opłata Fabryczna	992 Grams 992 Gramm 992 Gramów	709 Grams 709 Gramm 709 Gramow	1021 Grams 1021 Gramm 1021 Gramów	907 Grams 907 Gramm 907 Gramów	879 Grams 879 Gramm 879 Gramów
CO ₂ Equivalent CO ₂ Equivalent CO ₂ Ekwilalent	1.42 Tons 1,42 Tonnen 1,42Tony	1.02 Tons 1,02 Tonnen 1,02 Tony	1.46Tons 1,46 Tonnen 1,46Tony	1.30 Tons 1,30 Tonnen 1,30Tony	1.26 Tons 1,26 Tonnen 1,26 Tony



nVent
2100 Hoffman Way
Anoka, MN 55303 USA
☎ +1.763.422.2211
📠 +1.763.576.3200

nVent.com