

### Channel panel system for concealed roof & gutter de-icing

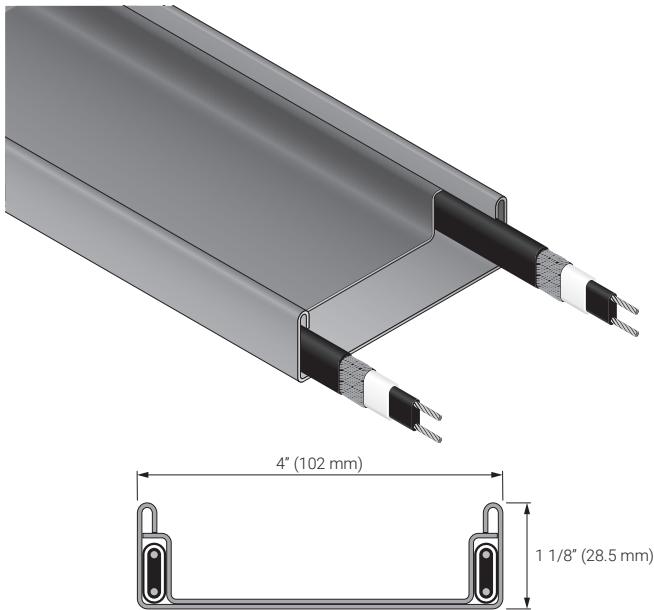

#### PRODUCT OVERVIEW

nVent RAYCHEM Roof Ice Melt (RIM) systems are designed to eliminate icicles and ice dam problems in wide range of applications.

The nVent RAYCHEM RIM Channel (RIM2-C) system is used to provide a heated channel for the snow melt to flow from one section of the roof to another, usually a drain or eave. The system consists of nVent RAYCHEM WFP heating cable, Aluminum extrusion designed to fit the cable and a cover panel for efficient heat transfer. The RIM2-C channel system uses two runs of WFP cable providing adequate power output necessary for moderate snow load areas.

RIM systems provide:

- Long term roof deicing solution by mechanically protecting the heating cable
- Aesthetically pleasing solution by concealing the heating cable
- High performance and reliable solution for moderate snow load areas



#### CATALOG NUMBER

RIM2-C, Channel System	Copper
RIM2-C, Channel System	Aluminum

#### CONTENTS

RIM-C	Base Panel (1 ft per foot of RIM-C)
	Cover Panel (1 ft per foot of RIM-C)
	WFP Heating Cable (2 ft per foot of RIM-C)

#### MATERIALS OF CONSTRUCTION

Extrusion	Aluminum
Base/Cover Panel	Aluminum
	Copper
	Custom
	Note: Refer to the RIM color guide (H59379) for a complete list of options.

## ADDITIONAL MATERIALS (AS REQUIRED)

Power Connection kits (WPCK-R)	Contains a heat shrink power connection and end seal designed for RIM systems
Splice/Tee Connection kits (FTC-HST-PLUS)	Heat shrink splice or tee kit designed for RIM systems
RIM Adhesive/Sealant	Silicone adhesive for RIM systems
	Note: Only approved connection kits and accessories must be used with RIM Systems. Refer to the RIM design guide (H59561) for proper selection.
End Seal kits	Heat shrink end seal kit designed for RIM systems

## PRODUCT SPECIFICATIONS (NOMINAL)

Power Output	16 W/ft of RIM-C (52 W/m of RIM-C) in snow or ice
Minimum Installation Temperature	0°F (-18°C)
Overall Cover Dimensions	Width: 1 5/8 in (41.3 mm) Thickness: 5/8 in (16 mm)
Weight	678 lb/1000 ft (1009 kg/km)

## HEATING CABLE SPECIFICATIONS (NOMINAL)

Voltage	WFP-612: 120 Vac
	WFP-622: 208- 277 Vac
Minimum Bend Radius	5/8 in (16 mm)

## CABLE SELECTION

Model number	Operating voltage	Power output in Snow/Ice (nominal)	Maximum circuit length vs Breaker size			
			20A CB		30A CB	
			@ 0°F	@ 32°F	@ 0°F	@ 32°F
WFP-612	120 Vac	8 W/ft	130 ft	165 ft	195 ft	240 ft
WFP-622	208-277 Vac	8 W/ft	270 ft	330 ft	405 ft	480 ft

**Note:** For 208 Vac application, multiply power output at 240 Vac by 0.85.  
For 277 Vac application, multiply power output at 240 Vac by 1.12.

## APPROVALS

The WFP-612 and WFP-622 heating cables are UL Listed and CSA Certified only when used with the appropriate agency-approved nVent RAYCHEM connection kits and accessories. For approvals information, refer to the WFP heating cable data sheet (H59576).

## GROUND-FAULT PROTECTION

To minimize the danger of fire from the sustained electrical arcing if the heating cable is damaged or improperly installed, and to comply with the requirements of nVent, agency certifications, and national electrical codes, ground-fault equipment protection must be used on each heating cable branch circuit. Arcing may not be stopped by conventional circuit protection. Many nVent RAYCHEM control and monitoring systems meet the ground-fault protection requirement.

## North America

Tel: +1.800.545.6258  
Fax: +1.800.527.5703  
thermal.info@nvent.com



Our powerful portfolio of brands:

**CADDY ERICO HOFFMAN RAYCHEM SCHROFF TRACER**