

Mounting Feet

1. Locate mounting foot stud location using the dimensions given (when holes are not provided).
2. Use center punch to mark hole centers, and drill four .5 inch (13 mm) diameter holes.
3. Deburr holes.

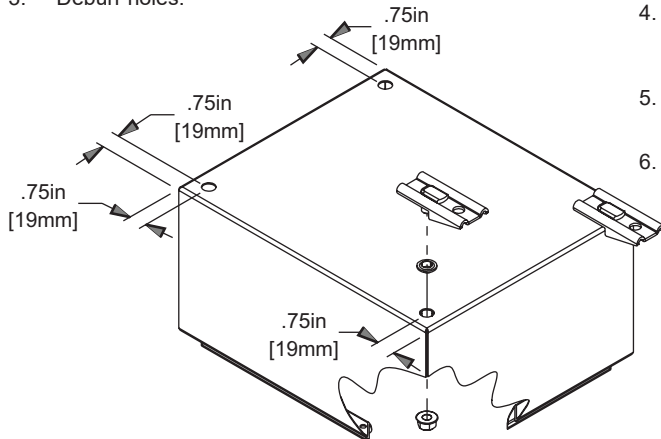

4. Insert sealing washers into holes from the outside, with the tapered cone toward the hole.
5. Insert mounting foot studs through sealing washers and turn enclosure upright.
6. Thread nuts onto mounting foot studs and tighten to 200 in-lbs. Note: If holes are pre-punched, omit steps 1-3.

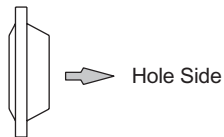

Sealing Washer Detail