

JBS-100-A, A6

Single Entry Power Connection with Junction Box Installation Instructions

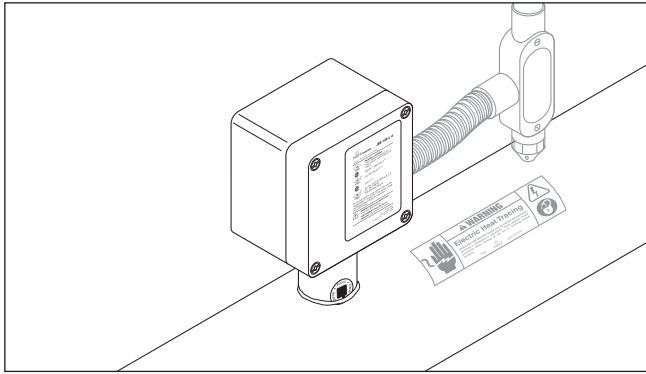

APPROVALS

Hazardous Locations



Class I, Div. 2, Groups A, B, C, D
 Class II, Div. 2, Groups E, F, G
 Class III



(JBS-100-A only) Ex eb IIC T* Gb

IECEX

JBS-100-A is IECEX certified for use with:
 BTV-CR/BTV-CT: IECEX BAS 20.0011X
 QTVR-CT: IECEX BAS 20.0013X
 XTV(R)-CT: IECEX BAS 20.0012X
 KTV-CT: IECEX BAS 20.0014X
 HTV-CT: IECEX PTB 21.0007X
 VPL-CT: IECEX BAS 20.0008X



Class I Division 2 (Zone 2**), Groups A, B, C, D
 Class I Zone 2 IIC



Ex eb IIC T* Gb; Class I Zone 1 AEx eb IIC T*Gb
 Ex tb IIIC T*C Db; Zone 21 AEx tb IIIC T*C Db

* For system Temperature Code, see heating cable or design documentation

(1) Except HTV

(2) Except KTV-CT

(3) For HTV-CT only ** Per CE Code Table 18

KIT CONTENTS

Item	Qty	Description
A	1	Stand assembly
B	1	Core sealer
C	1	Green/yellow tube
D	1	Cable lubricant
E	1	Cable tie
F	1	Lid
G	1	Box with terminal blocks

DESCRIPTION

The nVent RAYCHEM JBS-100-A and nVent RAYCHEM JBS-100-A6 are NEMA 4X-rated power connection kit. It is designed for use with nVent RAYCHEM BTV-CR, BTV-CT, QTVR-CT, XTV(R)-CT, KTV-CT, HTV-CT and VPL-CT industrial parallel heating cables.

The JBS-100-A6 utilizes larger terminal blocks to accommodate up to 6 AWG power wires.

These kits may be installed at temperatures as low as -67°F (-55°C), and the maximum ambient temperature of 132°F (56°C). For easier installation store above freezing until just before installation.

For technical support call nVent (800) 545-6258.

TOOLS REQUIRED

- Wire cutters
- Adjustable pliers
- Utility knife
- Needle nose pliers
- Large slotted screwdriver
- Marker
- Wire stripper (for VPL-CT)
- ¼ in or smaller flat-blade screwdriver

ADDITIONAL MATERIALS REQUIRED

- Pipe strap
- GT-66 or GS-54 glass cloth tape

OPTIONAL MATERIALS

- Recommended conduit drain:
 JB-DRAIN-PLUG-3/4IN P/N 278621-000
- Small pipe adapter for 1 in (25 mm) and smaller pipes:
 Catalog number JBS-SPA P/N E90515-000

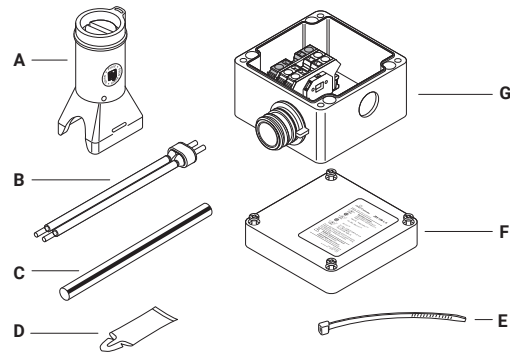

WARNING:

This component is an electrical device that must be installed correctly to ensure proper operation and to prevent shock or fire. Read these important warnings and carefully follow all of the installation instructions.

- To minimize the danger of fire from sustained electrical arcing if the heating cable is damaged or improperly installed, and to comply with the requirements of nVent agency certifications, and national electrical codes, ground-fault equipment protection must be used. Arcing may not be stopped by conventional circuit breakers.
- Component approvals and performance are based on the use of nVent-specified parts only. Do not use substitute parts or vinyl electrical tape.
- The black heating cable core and fibers are conductive and can short. They must be properly insulated and kept dry.
- Damaged bus wires can overheat or short. Do not break bus wire strands when scoring the jacket or core.
- Keep components and heating cable ends dry before and during installation.
- Use only fire-resistant insulation materials, such as fiberglass wrap and flame-retardant foam.

AVERTISSEMENT :

Ce composant électrique doit être installé correctement pour éviter les risques d'incendie ou de chocs électriques. Lire ces avertissements importants et suivre attentivement toutes les instructions d'installation.

- Pour réduire le danger d'incendie causé par un arc électrique entretenu, si le câble chauffant est endommagé ou mal installé, et pour respecter les exigences de nVent et celles des codes applicables, il est impératif d'utiliser une protection par disjoncteur différentiel. Les disjoncteurs ordinaires ne sont pas toujours capables de supprimer les arcs électriques.
- Les approbations et les performances des composants sont basées sur l'utilisation des pièces nVent spécifiées seulement. N'utilisez pas de pièces de rechange ou de ruban isolant en vinyle.
- Le noyau et les fibres du câble chauffant noir sont conducteurs et peuvent provoquer un court-circuit. Ils doivent être correctement isolés et gardés à sec.
- Les fils omnibus endommagés peuvent surchauffer ou subir un court-circuit.
- Ne brisez jamais les fils omnibus lorsque vous incisez la gaine ou le noyau.
- Maintenez les composants et les extrémités des câbles chauffants secs avant et pendant l'installation.
- Les fils omnibus peuvent provoquer un court-circuit s'ils se touchent. Les garder à l'écart les uns des autres
- N'utilisez que des matériaux isolants ininflammables, par exemple une gaine de fibre de verre ou de la mousse ignifuge.
- Laissez ces instructions d'installation à l'utilisateur pour qu'il puisse les consulter.

CAUTION:

HEALTH HAZARD: Prolonged or repeated contact with the sealant in the core sealer may cause skin irritation. Wash hands thoroughly. Overheating or burning the sealant will produce fumes that may cause polymer fume fever. Avoid contamination of cigarettes or tobacco. Consult MSDS VEN 0033 for further information.

CHEMTREC 24-hour emergency telephone: (800) 424-9300

Non-emergency health and safety information: (800) 545-6258.

MISE EN GARDE :

DANGER POUR LA SANTÉ : Le contact prolongé ou répété avec le produit d'étanchéité du noyau peut provoquer une irritation de la peau. Lavez-vous les mains soigneusement. La surchauffe et la combustion du produit d'étanchéité produira des vapeurs qui peuvent causer la fièvre des vapeurs de polymères. Évitez la contamination des cigarettes ou du tabac.

Consultez la fiche technique santé-sécurité (FTSS) VEN 0033 pour obtenir de plus amples informations.

Téléphone en cas d'urgence 24 heures sur 24 de CHEMTREC : (800) 424-9300

Renseignements non urgents en matière de santé et de sécurité : (800) 545-6258

Heating Cable Types

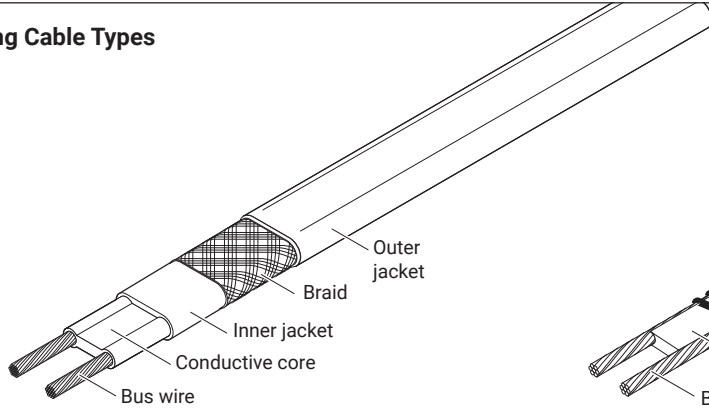

BTV-CR, BTV-CT, QTVR-CT

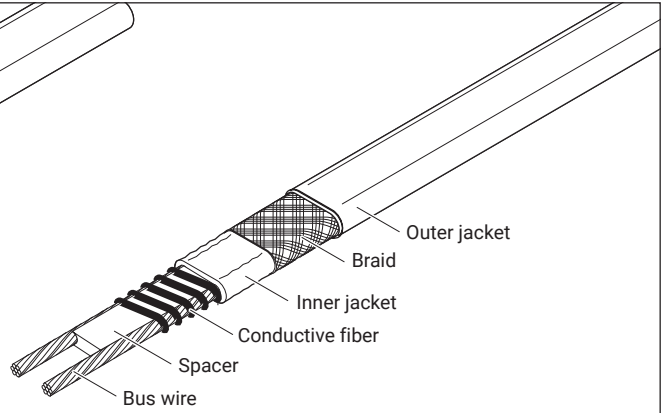

XTV(R)-CT, KTV-CT

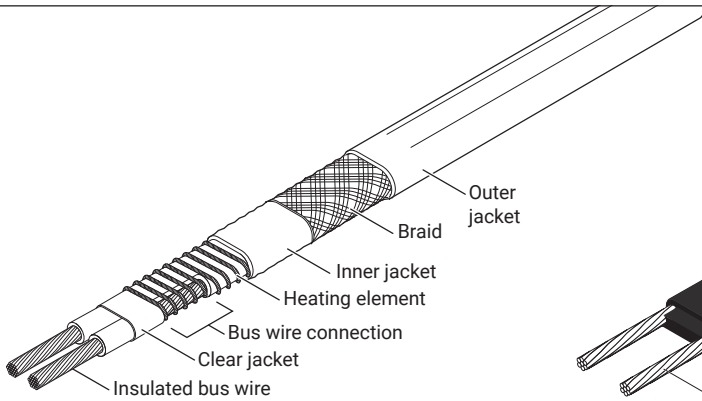

VPL-CT

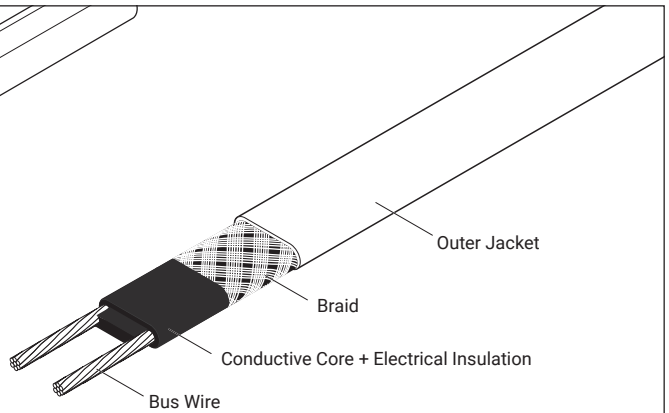

HTV-CT

1

- Allow approximately 24 in (60 cm) of heating cable for installation. For VPL, cut cable 12 in (30 cm) from bus indentation.
- Cut off heating cable end at about 45° for easier insertion.

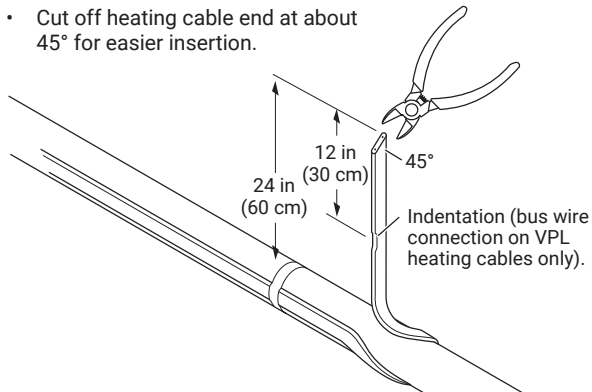

2

- Optional: If stand is to be installed on bottom side of pipe, knock out drain hole prior to inserting cable.
- With label on stand facing desired direction of box opening, push 18 in (45 cm) of heating cable through stand. Use cable lubricant if needed.
- Square off cable end with 90° cut.

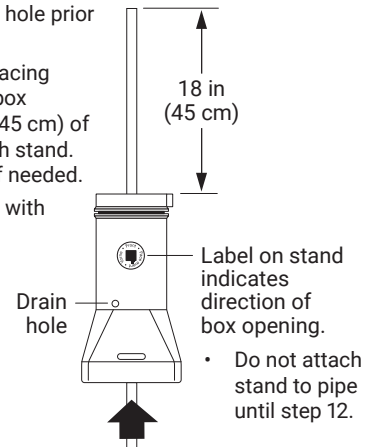
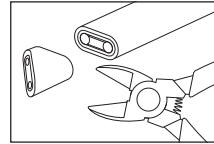

3

- Lightly score outer jacket around and down as shown.
- Bend heating cable to break jacket at score, then peel off jacket.

Do not cut braid.

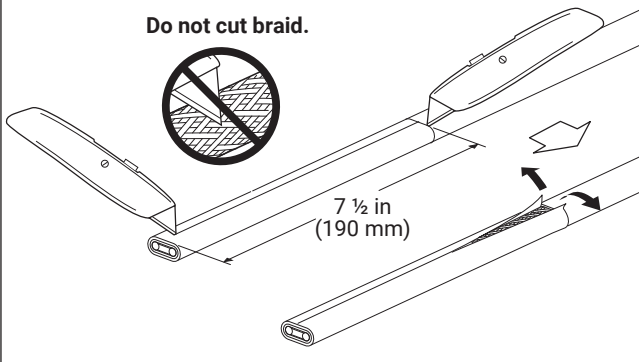

4

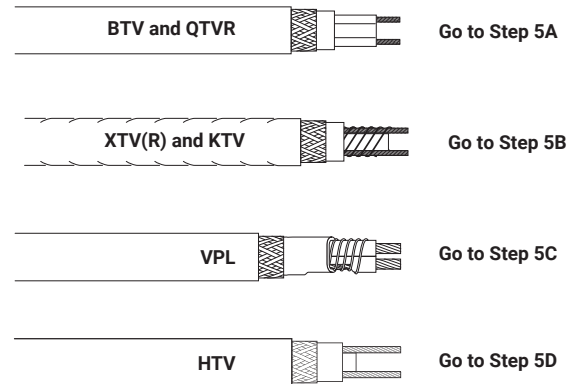

5A

BTV and QTVR

- Push braid back to create a pucker.

- At pucker use a screwdriver to open braid.
- Bend heating cable and work it through opening in braid.

- Lightly score inner jacket around and down as shown.
- Peel off inner jacket.

- Notch core.

- Peel bus wire from core.

- Score core between buswires at inner jacket.
- Bend and snap core.
- Peel core from bus wire.

- Remove any remaining core material from bus wires.
- Pull braid tight to make pigtail.

Go to Step 6

5B

XTV(R) and KTV

- Push braid back to create a pucker.

- At pucker use a screwdriver to open braid.
- Bend heating cable and work it through opening in braid.

- Lightly score inner jacket around and down as shown.
- Peel off inner jacket.

- Peel off inner jacket.

- Cut and remove all fiber strands.

- Score and remove center spacer.

- Remove any remaining fiber material from bus wires.
- Pull braid tight to make pigtail.

Go to Step 6

5C

VPL

- Push braid back and bunch as tight as possible.

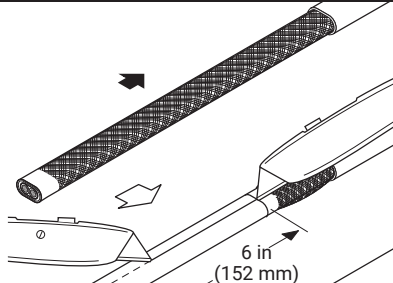

- Lightly score inner jacket around and down as shown.

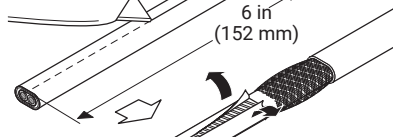

- Peel off inner jacket.

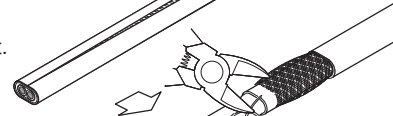

- Unwind heating element, cut and remove as shown.

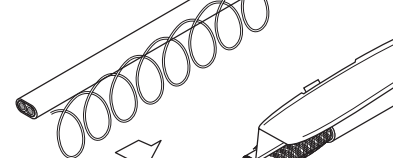

- Lightly score clear jacket around and down as shown.

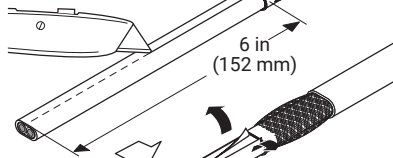

- Bend heating cable to break jacket at the score then peel off jacket.

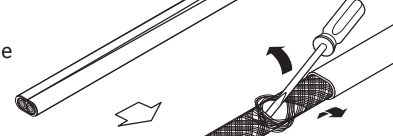

- Push braid forward. Use a screwdriver to open braid as shown.

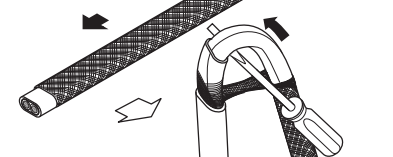

- Bend heating cable and work it through opening in braid.

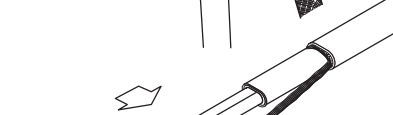

- Remove insulation from ends of bus wires.

- Pull braid tight to make pigtail.

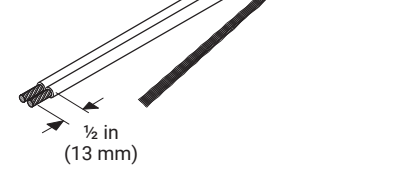

Go to Step 6

5D

HTV

- Push braid back to create a pucker.
- At pucker use a screwdriver to open braid.

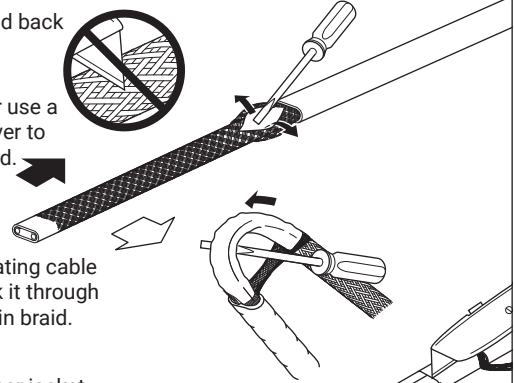

- Bend heating cable and work it through opening in braid.

- Score inner jacket and conductive core around and down as shown.

- Peel off inner jacket.

- Flip the cable 180°C and score the other side of inner jacket and conductive core.

- Remove the inner jacket, conductive core by using needle-nose pliers as shown.

- Score and remove center insulation.

- Remove any remaining material from bus wires.

- Pull braid tight to make pigtail.

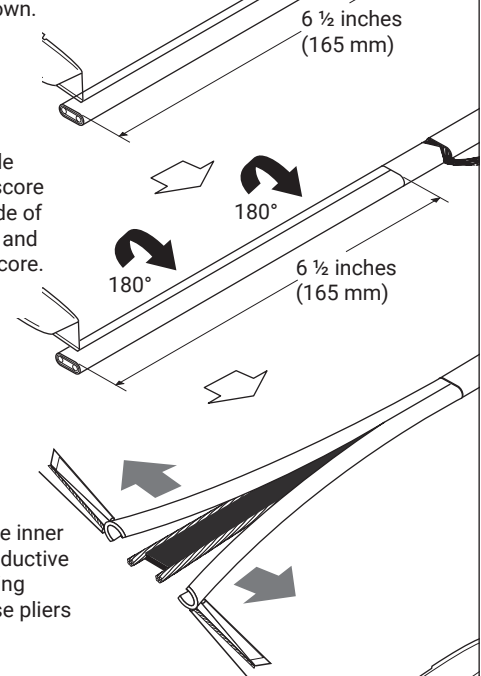

Go to Step 6

6

- Mark the jacket as shown.

5/8 in (15 mm)

7

⚠ CAUTION: Health Hazard. Wash hands after contact with sealant. Consult material safety data sheet VEN 0033.

⚠ AVERTISSEMENT : risque pour la santé. Se laver les mains après tout contact avec le produit d'étanchéité. Consulter la fiche de données de sécurité VEN 0033.

- If needed, re-twist and straighten bus wires, then insert into the guide tubes as shown.

Make sure all strands go into the tubes.

Tubes

8

- Push core sealer onto the heating cable to the mark made in step 6.

Note: Extra force may be required for larger cables or at lower temperatures.

Make sure the bus wires do not kink, bunch, or crossover.

9

- Remove the guide tubes and dispose of them in a plastic bag.

10

- Slip the green/yellow tube onto the braid. Heat-shrinking is not required.
- Trim bus wires and braid.

1/2 in (13 mm)

1/2 in (13 mm)

11

- Pull heating cable back into stand so 1 in (25 mm) is exposed as shown. Use cable lubricant if needed.

1 in (25 mm)

12

- Fasten stand to pipe with label facing desired direction of box opening. Do not pinch heating cable.
- Loop and tape extra heating cable to pipe.

⚠ CAUTION: To avoid pinching the heating cable, be sure the cable is not under the pipe strap.

⚠ AVERTISSEMENT : Pour éviter de pincer le câble chauffant, assurez-vous que le câble ne se trouve pas sous la sangle du tuyau.

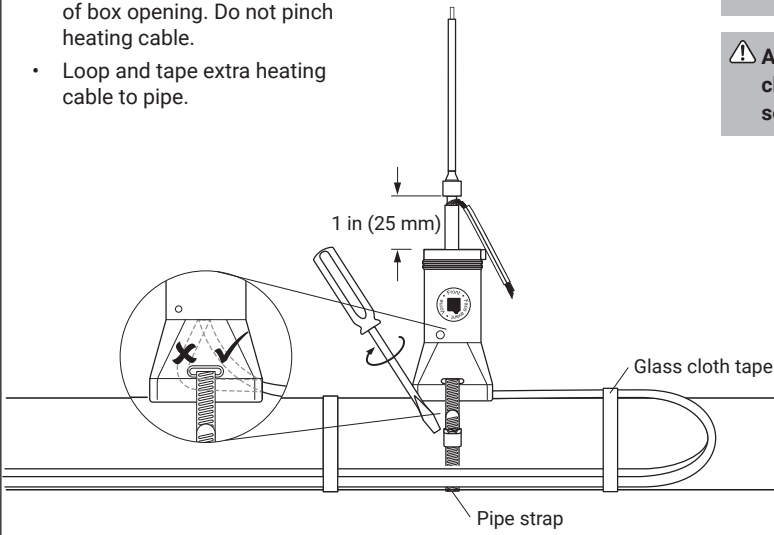

12A

Note: For 1 in (25 mm) and smaller pipes use adapter (purchased separately) and install between stand and pipe.

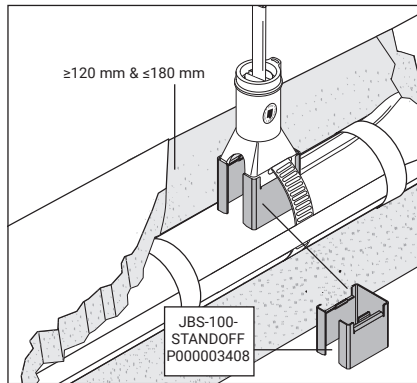
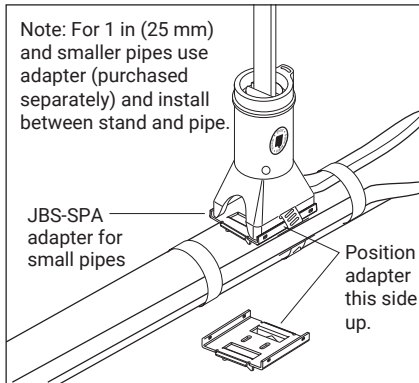

13

- Screw box onto stand until it stops. Do not overtighten.

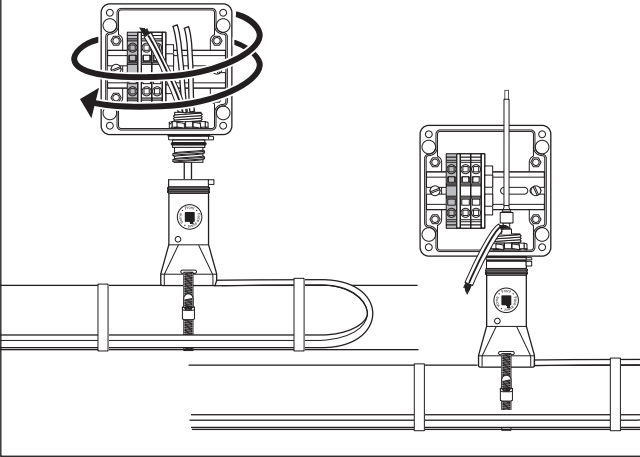

14

(Optional) To change direction of box opening:

- Loosen locknut using adjustable pliers.
- Lift box and rotate. Make sure tab on threaded piece fits into one of the four notches in box.
- Tighten locknut.

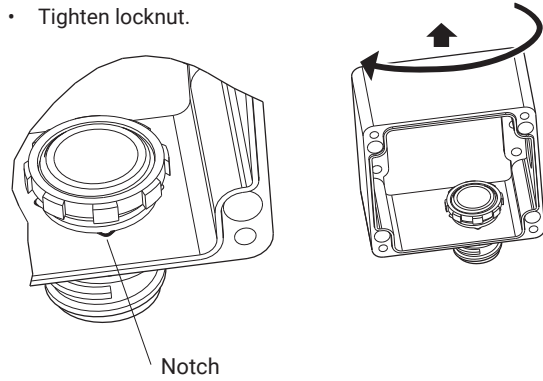

15

- Insert cable tie through slots on stand and box, and tighten firmly to prevent box rotation.

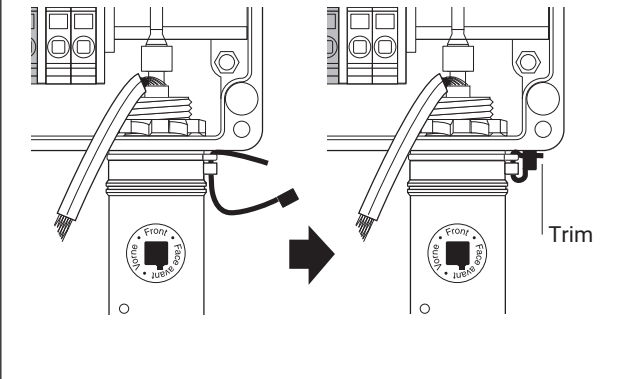

This kit uses spring clamp style terminals.

Terminals use a steel spring to clamp the wire to provide improved vibration resistance, reduced maintenance and faster installation.

To connect wires, firmly insert a slotted screwdriver into the square hole (①) to open the spring. When fully inserted, the screwdriver will lock into place, allowing you to remove your hand and insert the wire into the round hole (②). Remove the screwdriver to clamp the wire. The wire is held securely against the bus bar for low contact resistance over time without the need to periodically retighten screws.

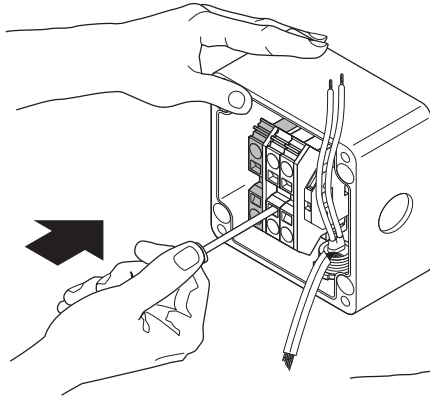

- Push screwdriver **FIRMLY** into square hole.

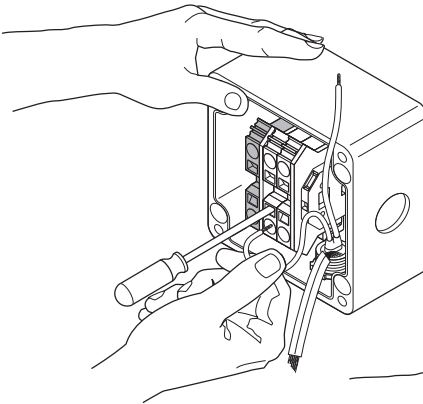

- Insert wire into round hole.
- Use green terminal for braid and ground wire.

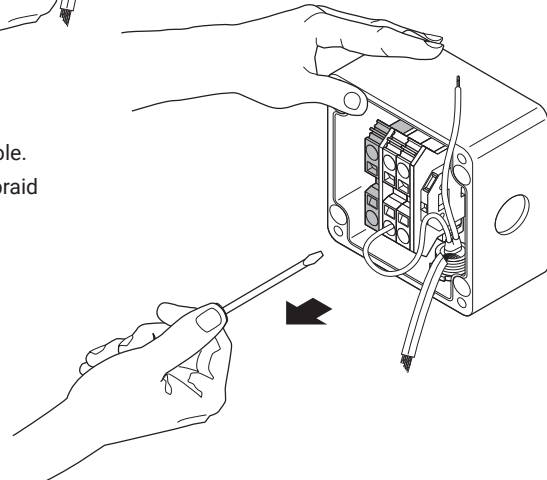

- Remove screwdriver.
- Repeat for all connections.

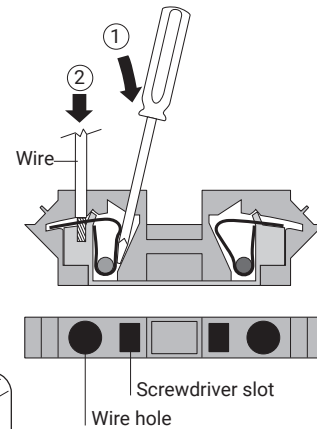

17

- Install conduit and fittings as shown. To minimize loosening due to pipe vibration, use flexible conduit.
- Pull in power and ground wires, strip off ½ in (13 mm) of insulation and terminate.

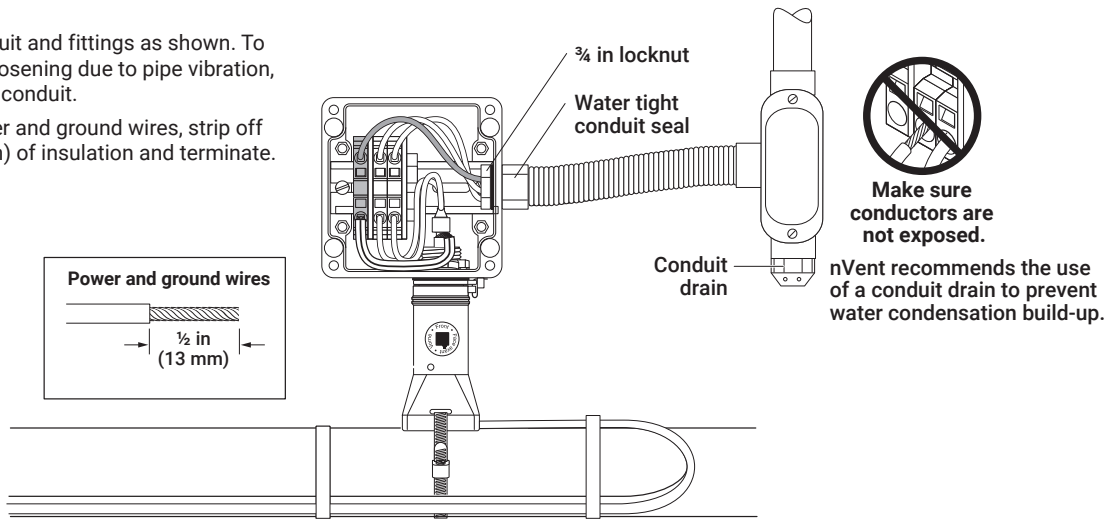

18

- Install lid. Torque = 1.02 to 1.47 Nm
- Apply insulation and cladding.
- Weather-seal the stand entry.
- Leave these instructions with the end user for future reference.

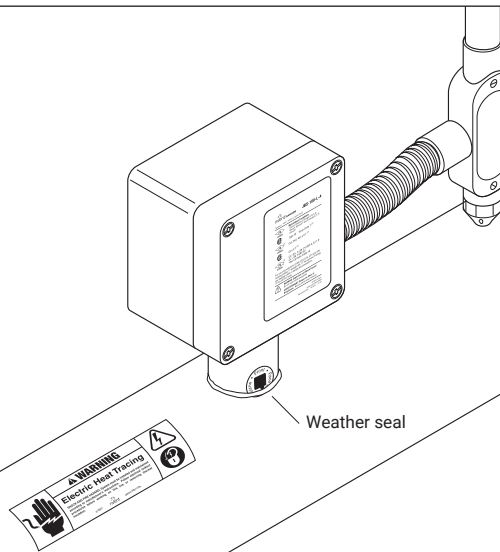

⚠ WARNING: Explosion Hazard- Substitution of Components May Impair Suitability for Class I Division 2 (Zone 2)

⚠ WARNING: Explosion Hazard- Do not disconnect equipment unless power has been switched off or the area is known to be Non-Hazardous.

⚠ AVERTISSEMENT- Risque d'explosion. La substitution de composants peut rendre ce matériel inacceptable pour les emplacements de classe I, division 2 (zone 2).

⚠ AVERTISSEMENT- Risque d'explosion. Ne pas débrancher l'appareil à moins d'avoir coupé l'alimentation électrique ou à moins qu'il ne s'agisse d'un emplacement non dangereux

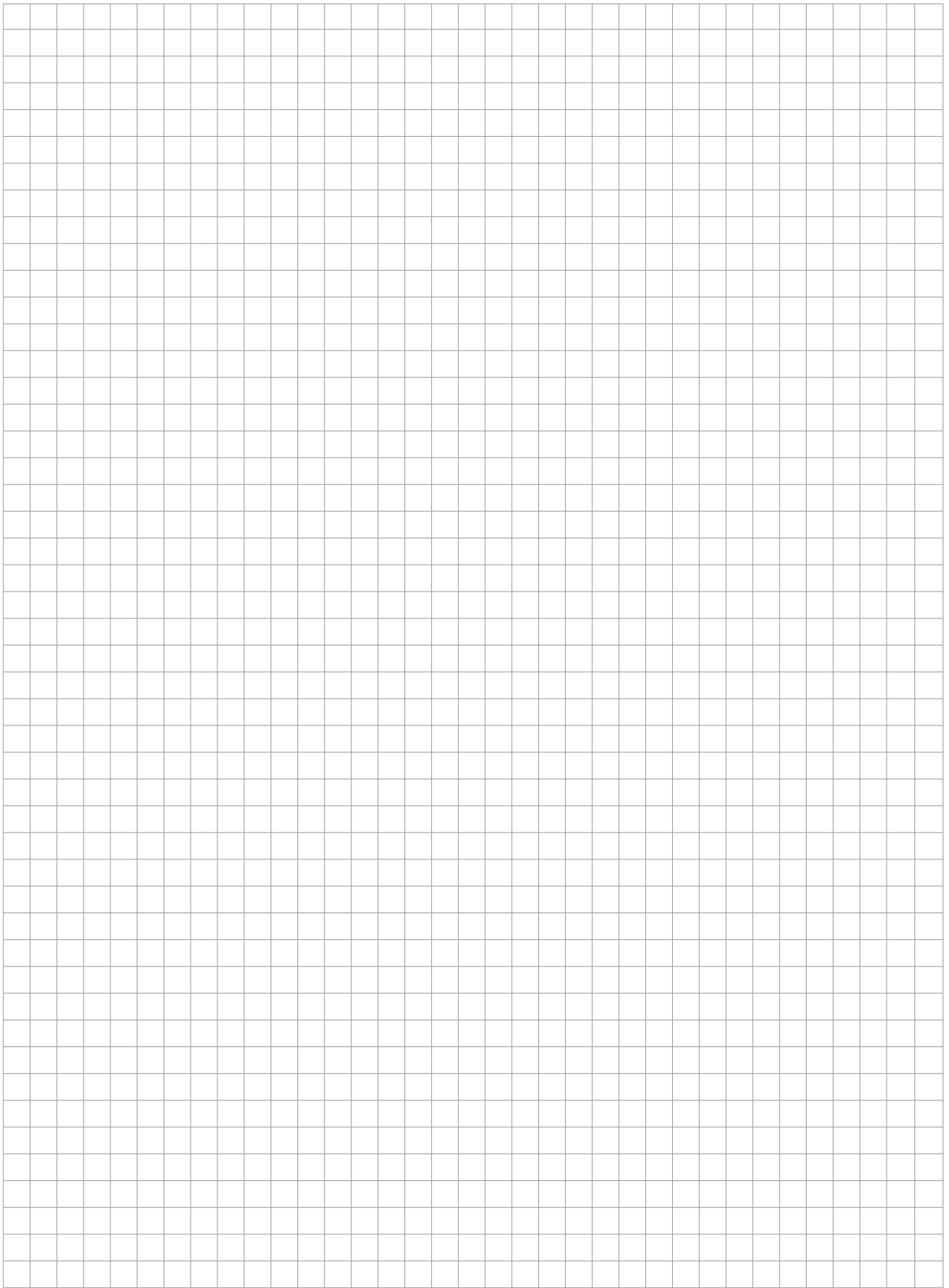

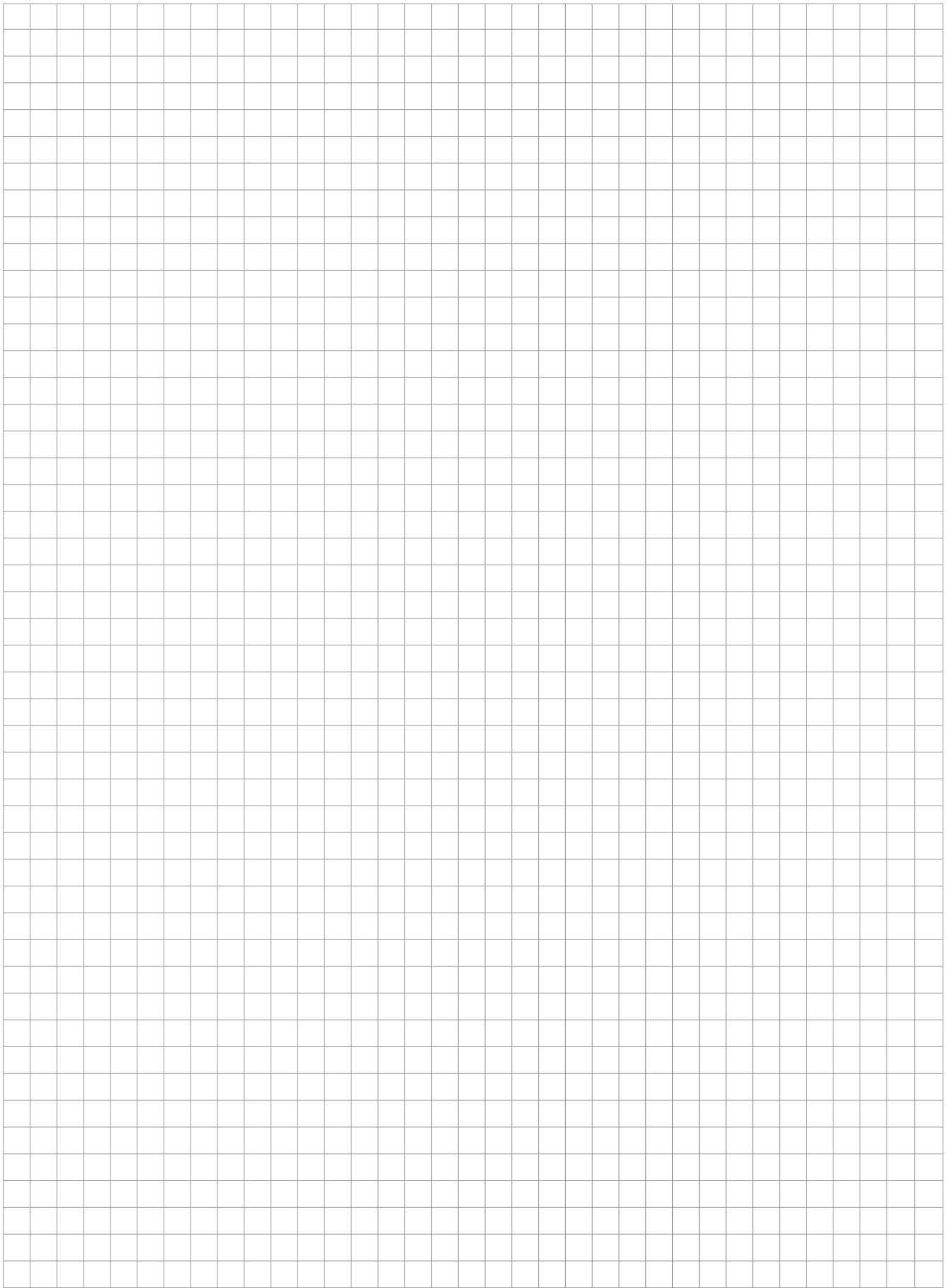

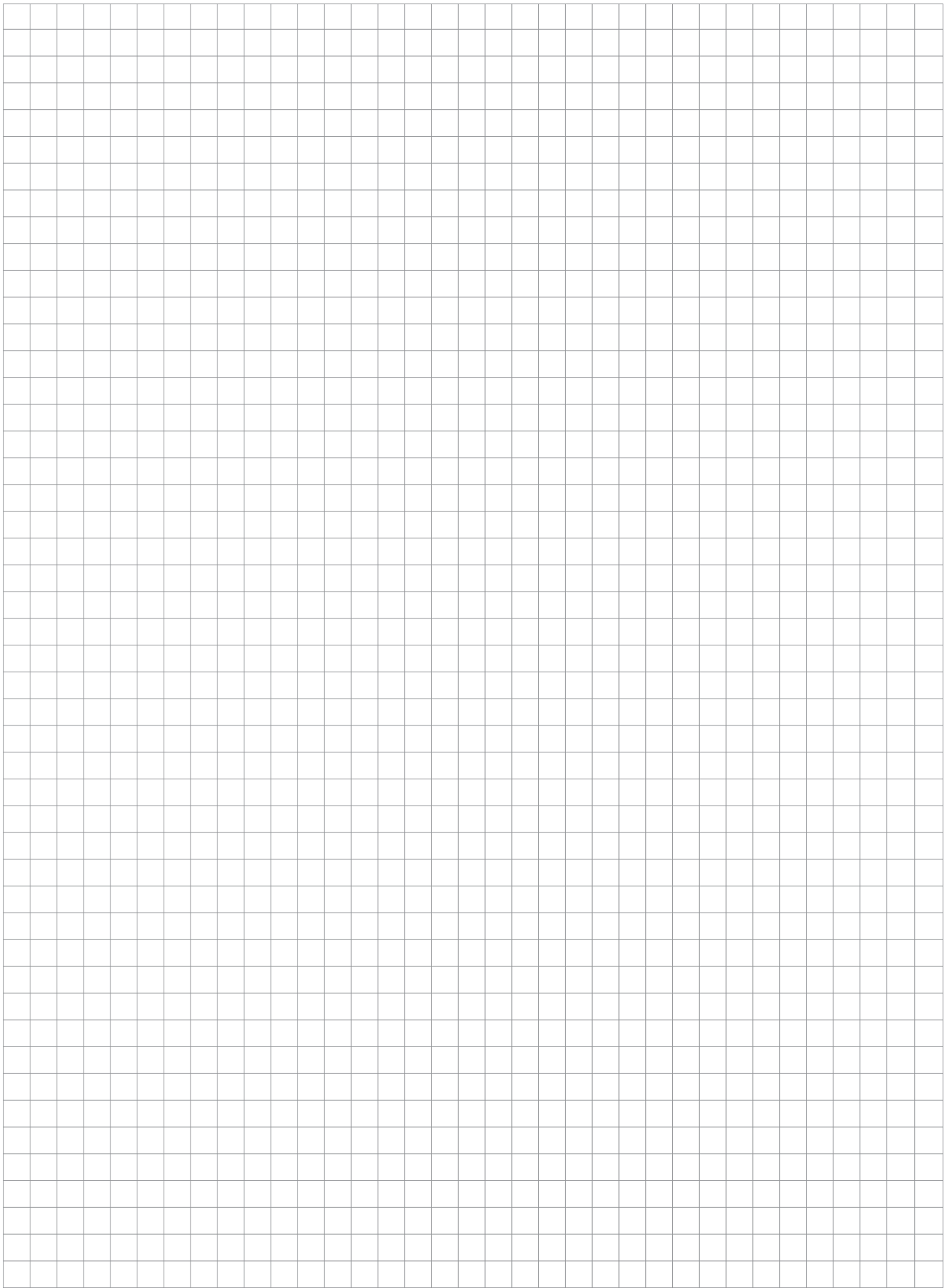

North America

Tel +1.800.545.6258
Fax +1.800.527.5703
thermal.info@nVent.com

Europe, Middle East, Africa

Tel +32.16.213.511
Fax +32.16.213.604
thermal.info@nVent.com

Asia Pacific

Tel +86.21.2412.1688
Fax +86.21.5426.3167
cn.thermal.info@nVent.com

Latin America

Tel +1.713.868.4800
Fax +1.713.868.2333
thermal.info@nVent.com



[nVent.com/RAYCHEM](https://www.nVent.com/RAYCHEM)