

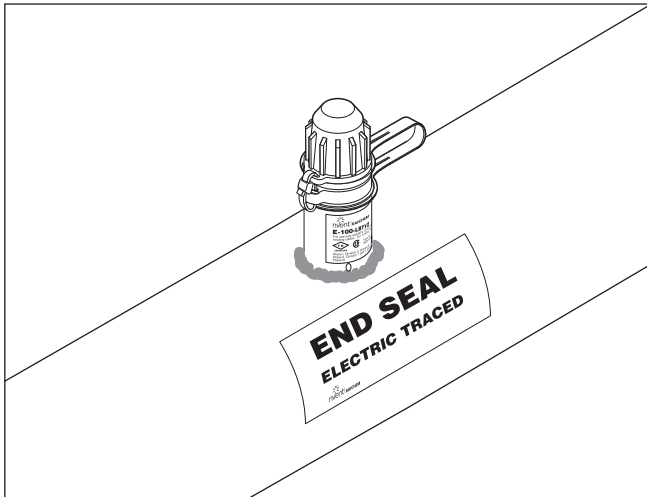

RAYCHEM

E-100-LBTV2

High-Profile End Seal Installation Instructions



APPROVALS

Hazardous Locations



Class I, Div. 2, Groups A, B, C, D
 Class II, Groups F, G
 Class III
 CL I, ZN1, AEx e II T6 (1)



CL I ZN 1 AEx eb IIC T6 Gb
 Ex eb IIC T6 Gb

(1) FM only

KIT CONTENTS

Item	Qty	Description
A	1	End seal assembly
B	1	Cable tie
C	1	End seal label
D	1	Cable lubricant

DESCRIPTION

The nVent RAYCHEM E-100-LBTV2 is a NEMA 4X-rated end seal kit for use with nVent RAYCHEM LBTV2-CT heating cables. Once installed, the end seal is easily re-entered for maintenance; the heating cable can be accessed without removing the end seal.

This kit may be installed at temperatures as low as -40°F (-40°C).

For easier installation store above freezing until just before installation.

For technical support call nVent at (800) 545-6258.

TOOLS REQUIRED

- Wire cutters
- Slotted screwdriver or nut driver
- Utility knife
- Adjustable pliers (two required)

MATERIALS REQUIRED

- Pipe strap
- GT-66 or GS-54 glass cloth tape

OPTIONAL MATERIALS

- For boot replacement order E-100-LBTV2-BOOT-5/PACK P/N 335089-000

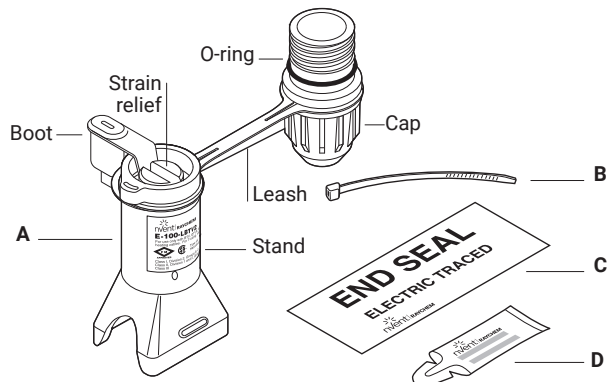

⚠ WARNING:

This component is an electrical device that must be installed correctly to ensure proper operation and to prevent shock or fire. Read these important warnings and carefully follow all of the installation instructions.

- To minimize the danger of fire from sustained electrical arcing if the heating cable is damaged or improperly installed, and to comply with the requirements of nVent, agency certifications, and national electrical codes, ground-fault equipment protection must be used. Arcing may not be stopped by conventional circuit breakers.
- Component approvals and performance are based on the use of nVent-specified parts only.

- Do not substitute parts or vinyl electrical tape.
- The black heating cable core is conductive and can short. It must be properly insulated and kept dry.
- Keep components and heating cable ends dry before and during installation.
- Bus wires will short if they contact each other. Keep bus wires separated.
- Use only fire-resistant insulation materials such as fiberglass wrap.
- Leave these installation instructions with the user for future reference.

⚠ CAUTION:

Health Hazard: Prolonged or repeated contact with the sealant in the end seal boot may cause skin irritation. Wash hands thoroughly. Overheating or burning the sealant will produce fumes that may cause polymer fume fever. Avoid contamination of cigarettes or tobacco. Consult MSDS VEN 0058 for further information.

CHEMTREC 24-hour emergency telephone:
(800) 424-9300

Non-emergency health and safety information:
(800) 545-6258.

- This product is for use only with LBTV2-CT heating cables.

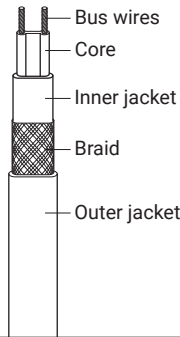

1

- Cut heating cable as shown.

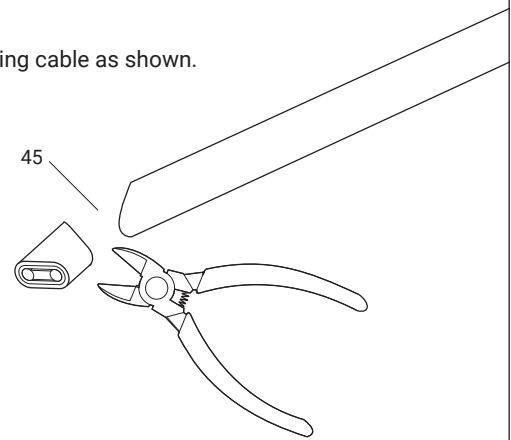

2

- Lubricate end of outer jacket.

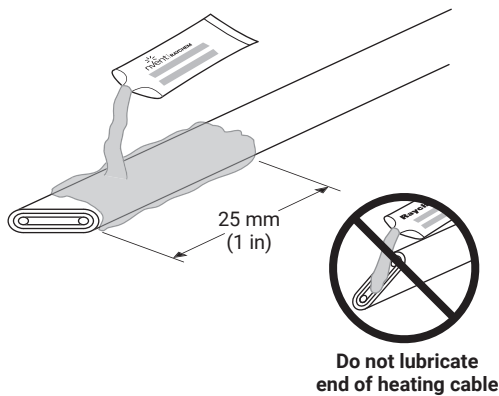

- Optional: If stand is to be installed on bottom side of pipe, knock out drain hole prior to installing cable.
- Immediately push heating cable through stand as shown.
- Square off heating cable end with a 90° angle cut.

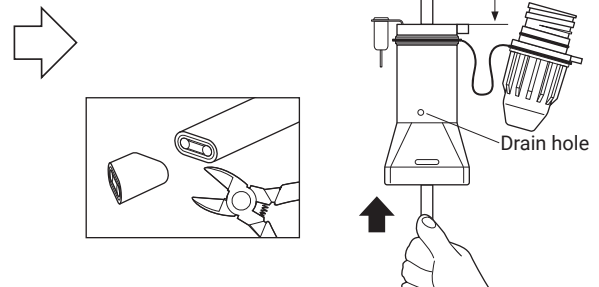

3

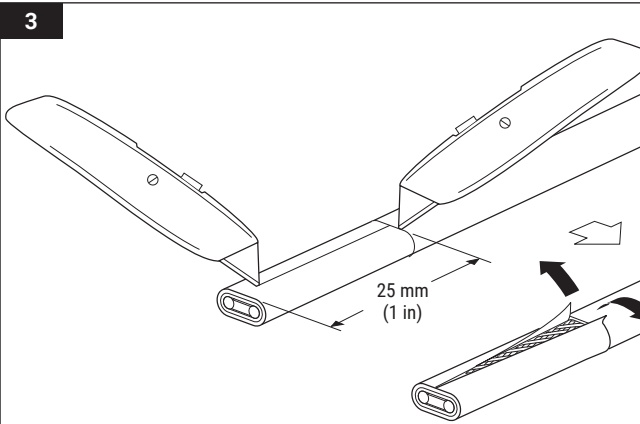

- Lightly score outer jacket.
- Bend heating cable to break jacket at score, then peel off jacket.

4

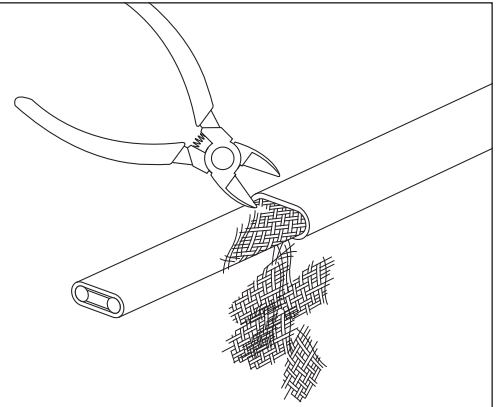

- Remove all exposed braid.

5

- Pull heating cable back into stand until top edge of outer jacket is aligned with top of stand.

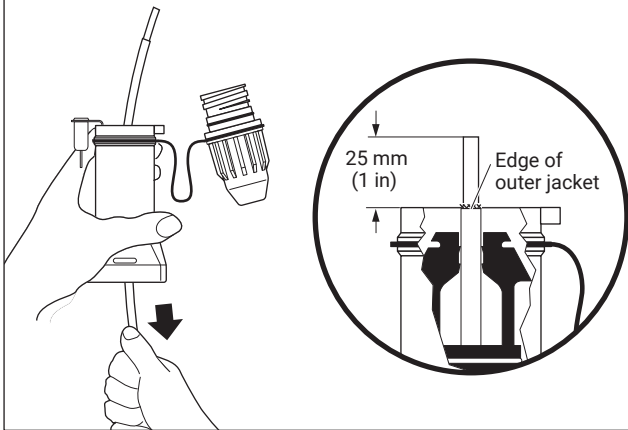

6

CAUTION: Health Hazard. Wash hands after contact with sealant. Consult material safety data sheet VEN 0058.

- Push boot onto the end of the heating cable until it bottoms out. Be careful not to squeeze sealant out of boot.

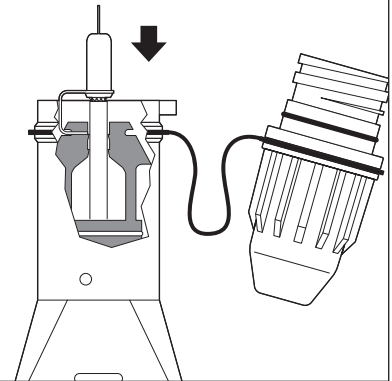

7

- Install cap; tighten until slots on cap and stand align.

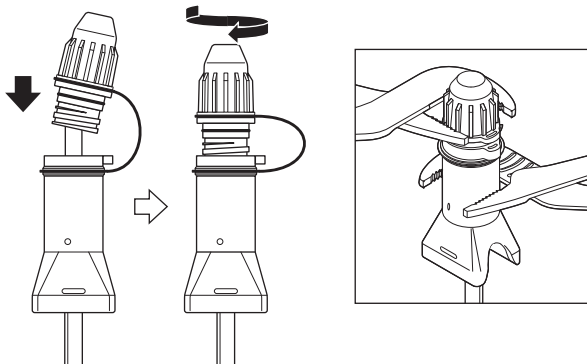

8

- Fasten end seal to pipe with strap. Do not pinch heating cable.
- Install cable tie.
- Loop and tape extra heating cable to pipe.
- Apply insulation and cladding.
- Weather-seal the stand entry.
- Fasten label to insulation.
- Leave these installation instructions with the user for future reference.

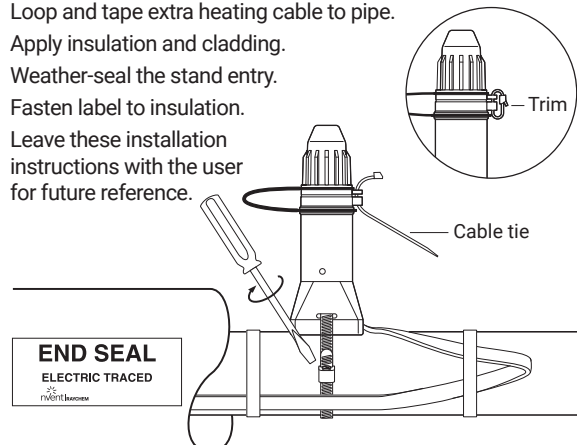

E-100-LBTV2 RE-ENTRY

A

⚠ WARNING: Shock Hazard. Conductors will be exposed. Re-entry should be performed by qualified personnel. Follow standard electrical lockout procedures before opening end seal.

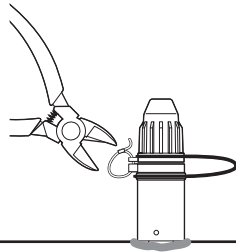

- Turn off power.
- Clip cable tie and remove.

END SEAL
ELECTRIC TRACED

B

- Remove cap.

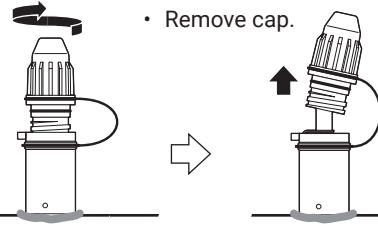

END SEAL
ELECTRIC TRACED

END SEAL
ELECTRIC TRACED

C

⚠ CAUTION: Health Hazard. Wash hands after contact with sealant. Consult material safety data sheet VEN 0058.

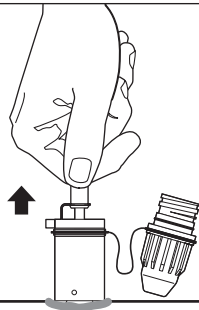

- Remove boot. Be careful not to squeeze sealant out of boot.

END SEAL
ELECTRIC TRACED

D

- Test as required.

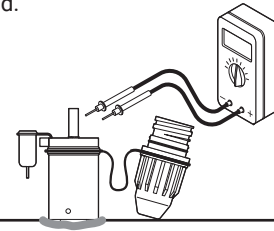

END SEAL
ELECTRIC TRACED

E

- **Inspect boot.** If boot is damaged or sealant appears dry or missing, replace boot. For replacement boots, order kit E-100-LBTV2-BOOT-5/PACK. Otherwise, re-install boot.

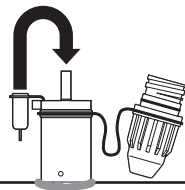

END SEAL
ELECTRIC TRACED

F

- Install cap; tighten until slots on cap and stand align.
- Install cable tie.

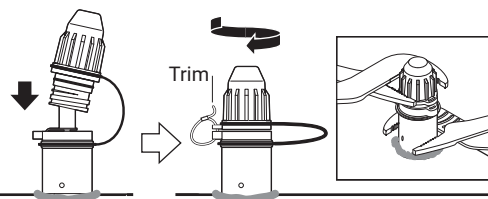

END SEAL
ELECTRIC TRACED

END SEAL
ELECTRIC TRACED

North America

Tel +1.800.545.6258
Fax +1.800.527.5703
thermal.info@nVent.com

Europe, Middle East, Africa

Tel +32.16.213.511
Fax +32.16.213.604
thermal.info@nVent.com

Asia Pacific

Tel +86.21.2412.1688
Fax +86.21.5426.3167
cn.thermal.info@nVent.com

Latin America

Tel +1.713.868.4800
Fax +1.713.868.2333
thermal.info@nVent.com



nVent.com/RAYCHEM