

## JBS-100-STB

Single Entry Power Connection With Junction Box  
Installation Instructions

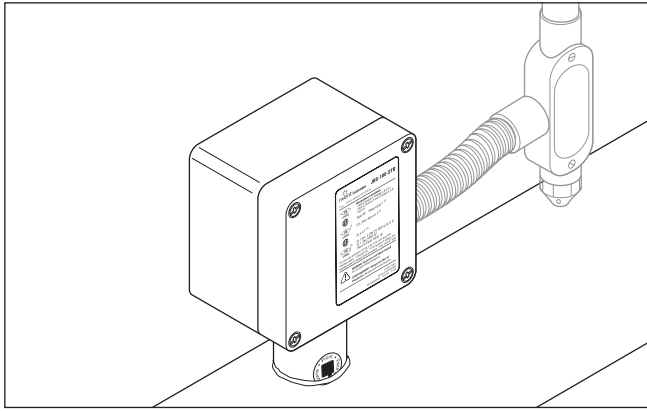

## DESCRIPTION

The nVent RAYCHEM JBS-100-STB is a NEMA 4X rated power connection kit. It is designed for use with BTV-CR, BTV-CT, QTVR-CT, XTV(R)-CT, KTV-CT, HTV-CT and VPL-CT industrial parallel heating cables.

The JBS-100-STB utilizes screw terminal blocks to connect the heating cable to power.

This kit may be installed at temperatures as low as -67°F (-55°C). For easier installation store above freezing until just before installation.

For technical support call your local nVent representative.

## APPROVALS

### Hazardous Locations



(1) Class I, Div. 2, Groups A, B, C, D  
Class II, Div. 1 and 2, Groups E, F, G  
Class III



(1) Temp Code\*



(2) Class I Division 2 (Zone 2\*\*), Groups A, B, C, D  
Class I Zone 2 IIC



CL I ZN 1 AEx eb IIC T\* Gb  
ZN 21 AEx tb IIIC T\* C Db  
Ex eb IIC T\* Gb  
Ex tb IIIC T\* C Db

\* For system Temperature Code, see heating cable or design documentation

(1) Except HTV

(2) For HTV-CT only \*\* Per CE Code Table 18

## KIT CONTENTS

Item	Qty	Description
A	1	Stand
B	1	Core sealer
C	1	Green/yellow tube
D	1	Cable lubricant
E	1	Cable tie
F	1	Lid
G	1	Box with terminal block

## TOOLS REQUIRED

- Wire cutters
- Pliers or adjustable wrench
- Utility knife
- Needle nose pliers
- Large slotted screwdriver
- Marker
- ¼ in or smaller flat-blade screwdriver
- Wire stripper (for VPL-CT)

## ADDITIONAL MATERIALS REQUIRED

- Pipe strap
- GT-66 or GS-54 glass cloth tape

## OPTIONAL MATERIALS

- Recommended conduit drain:  
JB-DRAIN-PLUG-3/4IN P/N 278621-000
- Small pipe adapter for 1 in (25 mm) and smaller pipes:  
Catalog number JBS-SPA P/N E90515-000

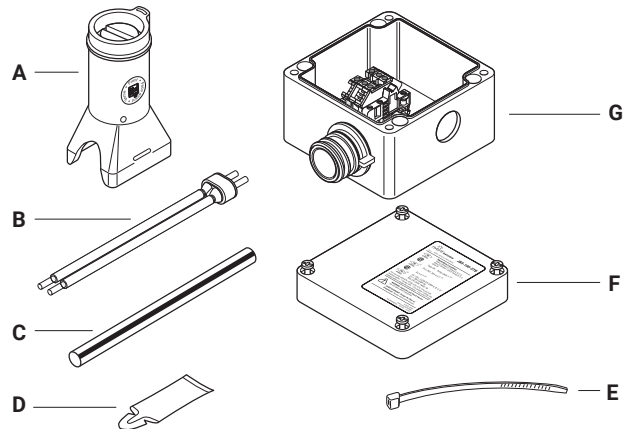

## **WARNING:**

This component is an electrical device that must be installed correctly to ensure proper operation and to prevent shock or fire. Read these important warnings and carefully follow all of the installation instructions.

- To minimize the danger of fire from sustained electrical arcing if the heating cable is damaged or improperly installed, and to comply with the requirements of nVent, agency certifications, and national electrical codes, ground-fault equipment protection must be used. Arcing may not be stopped by conventional circuit breakers.
- Component approvals and performance are based on the use of nVent-specified parts only. Do not use substitute parts or vinyl electrical tape.

- The black heating cable core and fibers are conductive and can short. They must be properly insulated and kept dry.
- Damaged bus wires can overheat or short. Do not break bus wire strands when scoring the jacket or core.
- Keep components and heating cable ends dry before and during installation.
- Use only fire-resistant insulation materials, such as fiberglass wrap and flame-retardant foam.

## **AVERTISSEMENT :**

Ce composant électrique doit être installé correctement pour éviter les risques d'incendie ou de chocs électriques. Lire ces avertissements importants et suivre attentivement toutes les instructions d'installation.

- Pour réduire le danger d'incendie causé par un arc électrique entretenu, si le câble chauffant est endommagé ou mal installé, et pour respecter les exigences de nVent et celles des codes applicables, il est impératif d'utiliser une protection par disjoncteur différentiel. Les disjoncteurs ordinaires ne sont pas toujours capables de supprimer les arcs électriques.
- Les approbations et les performances des composants sont basées sur l'utilisation des pièces nVent spécifiées seulement. N'utilisez pas de pièces de rechange ou de ruban isolant en vinyle.

- Le noyau et les fibres du câble chauffant noir sont conducteurs et peuvent provoquer un court-circuit. Ils doivent être correctement isolés et gardés à sec.
- Les fils omnibus endommagés peuvent surchauffer ou subir un court-circuit.
- Ne brisez jamais les fils omnibus lorsque vous incisez la gaine ou le noyau.
- Maintenez les composants et les extrémités des câbles chauffants secs avant et pendant l'installation.
- Les fils omnibus peuvent provoquer un court-circuit s'ils se touchent. Les garder à l'écart les uns des autres
- N'utilisez que des matériaux isolants ininflammables, par exemple une gaine de fibre de verre ou de la mousse ignifuge.
- Laissez ces instructions d'installation à l'utilisateur pour qu'il puisse les consulter.

## **CAUTION:**

**HEALTH HAZARD:** Prolonged or repeated contact with the sealant in the core sealer may cause skin irritation. Wash hands thoroughly. Overheating or burning the sealant will produce fumes that may cause polymer fume fever. Avoid contamination of cigarettes or tobacco. Consult MSDS VEN 0058 for further information.

CHEMTREC 24-hour emergency telephone: (800) 424-9300

Non-emergency health and safety information: (800) 545-6258.

## **MISE EN GARDE :**

**DANGER POUR LA SANTÉ :** Le contact prolongé ou répété avec le produit d'étanchéité du noyau peut provoquer une irritation de la peau. Lavez-vous les mains soigneusement. La surchauffe et la combustion du produit d'étanchéité produira des vapeurs qui peuvent causer la fièvre des vapeurs de polymères. Évitez la contamination des cigarettes ou du tabac. Consultez la fiche technique santé-sécurité (FTSS) VEN 0058 pour obtenir de plus amples informations.

Téléphone en cas d'urgence 24 heures sur 24 de CHEMTREC : (800) 424-9300

Renseignements non urgents en matière de santé et de sécurité : (800) 545-6258

**Heating Cable Types**

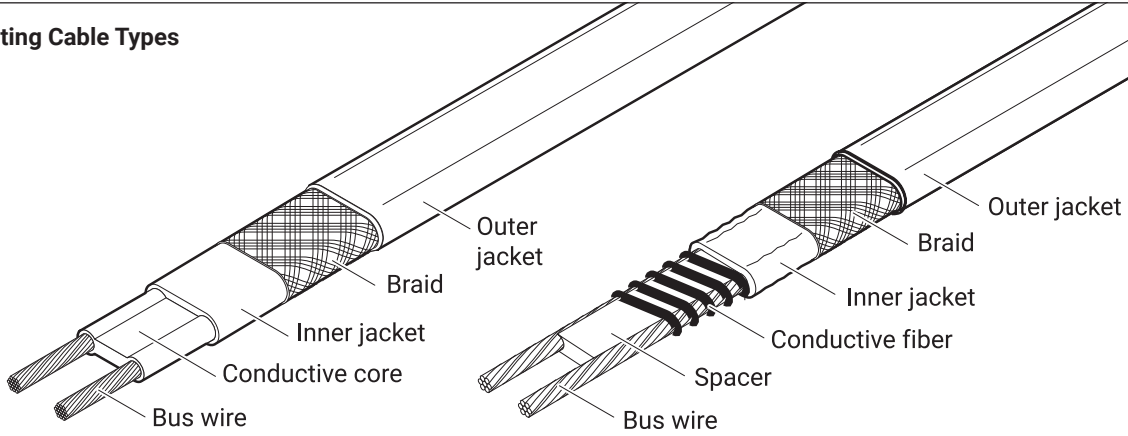

**BTV-CR, BTV-CT, QTVR-CT**

**XTV-CT, KTV-CT**

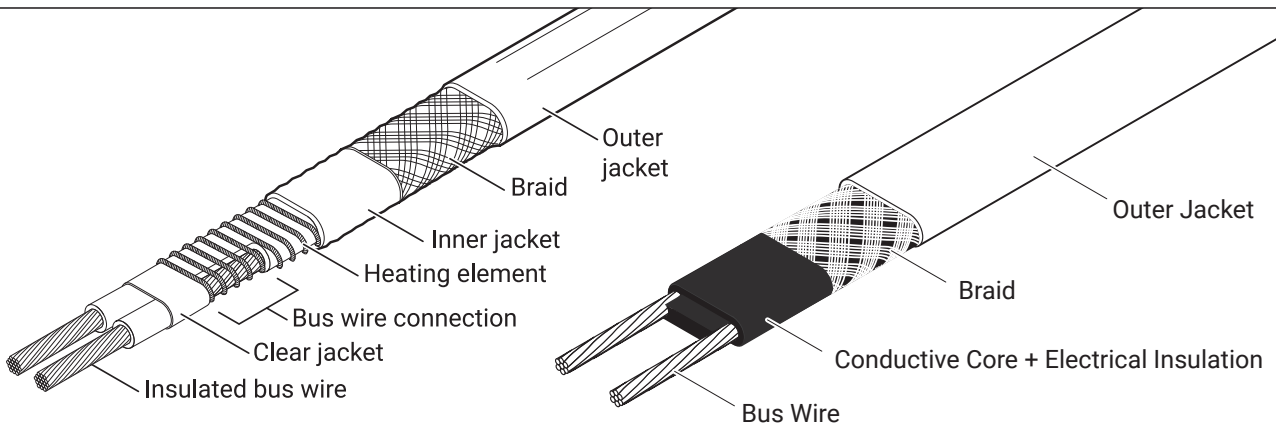

**VPL-CT**

**HTV-CT**

1

- Allow approximately 24 in (60 cm) of heating cable for installation. For VPL, cut cable 12 in (30 cm) from bus indentation.
- Cut off heating cable end at about 45° for easier insertion.

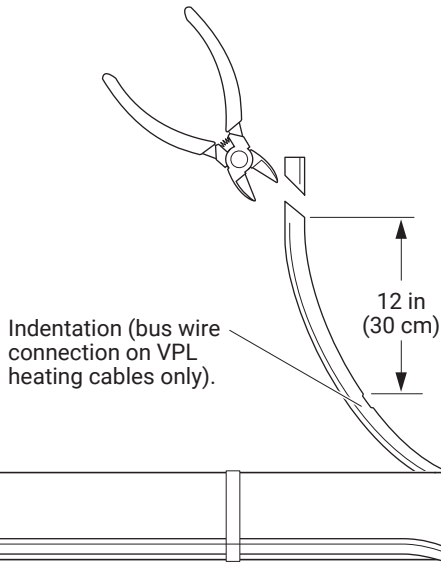

2

- Optional: If stand is to be installed on bottom side of pipe, knock out drain hole prior to inserting cable.
- With label on stand facing desired direction of box opening, push 18 in (45 cm) of heating cable through stand. Use cable lubricant if needed.
- Square off cable end with 90° cut.

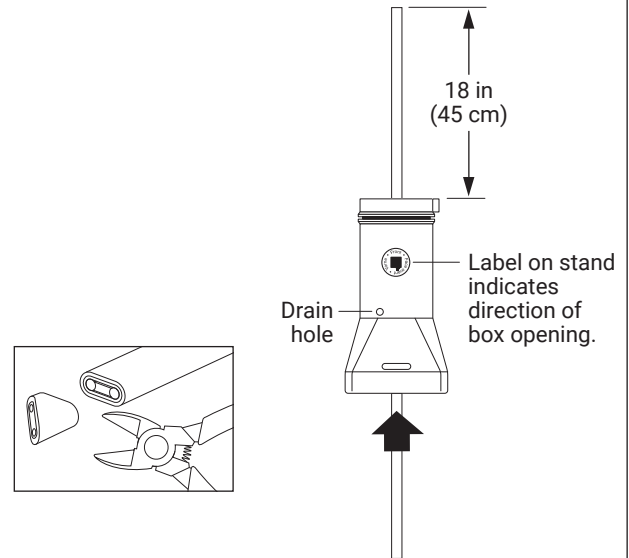

3

- Lightly score outer jacket around and down as shown.
- Bend heating cable to break jacket at score, then peel off jacket.

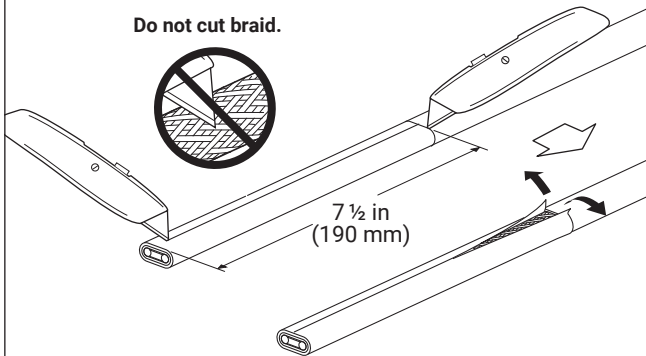

4

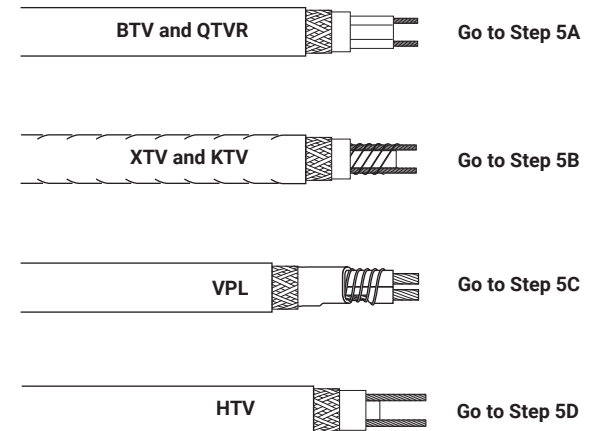

5A

BTV and QTVR



- Push braid back to create a pucker.
- At pucker use a screwdriver to open braid.
- Bend heating cable and work it through opening in braid.
- Lightly score inner jacket around and down as shown.
- Peel off inner jacket.
- Notch core.
- Peel bus wire from core.
- Score core between bus wires at inner jacket.
- Bend and snap core.
- Peel core from bus wire.
- Remove any remaining core material from bus wires.
- Pull braid tight to make pigtail.

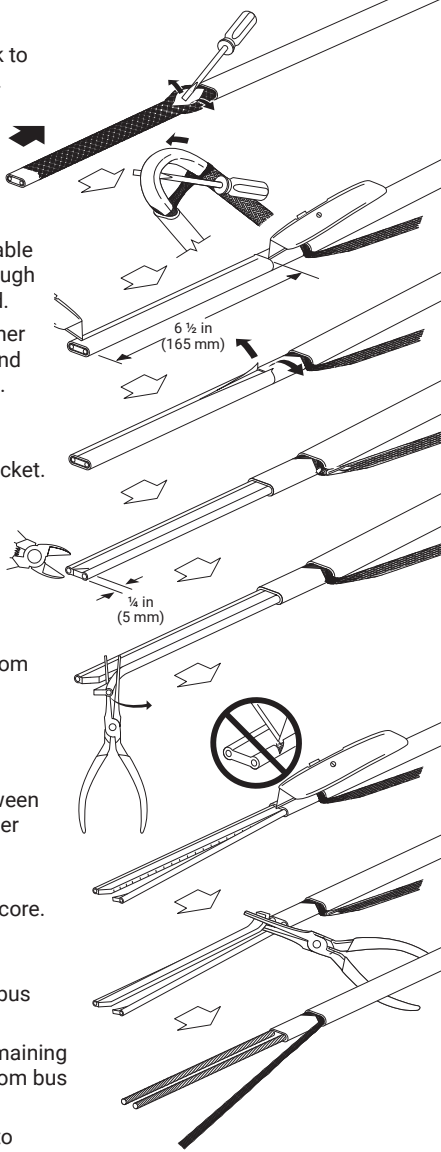

Go to Step 6

5B

XTV and KTV



- Push braid back to create a pucker.
- At pucker use a screwdriver to open braid.
- Bend heating cable and work it through opening in braid.
- Lightly score inner jacket around and down as shown.
- Peel off inner jacket.
- Cut and remove all fiber strands.
- Score and remove center spacer.
- Remove any remaining fiber material from bus wires.
- Pull braid tight to make pigtail.

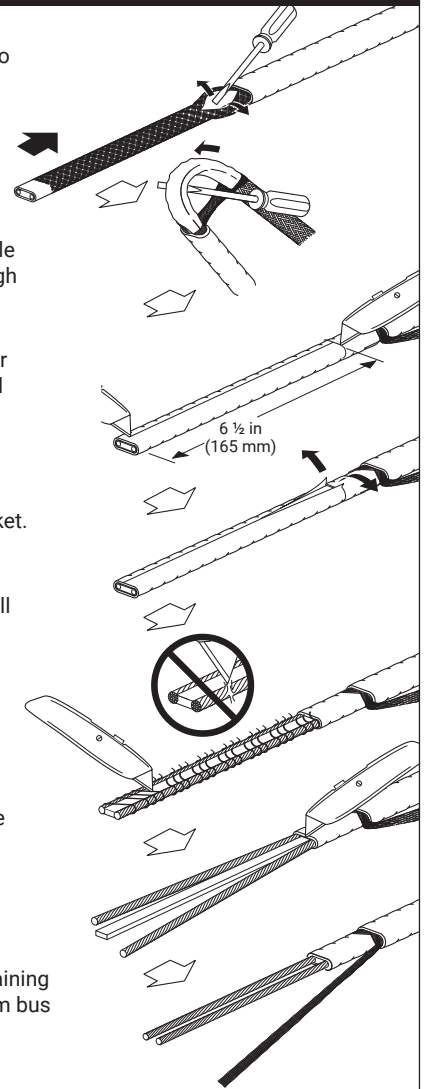

Go to Step 6

5C

VPL

- Push braid back and bunch as tight as possible.
- Lightly score inner jacket around and down as shown.
- Peel off inner jacket.
- Unwind heating element, cut and remove as shown.
- Lightly score clear jacket around and down as shown.
- Bend heating cable to break jacket at the score then peel off jacket.
- Push braid forward. Use a screwdriver to open braid as shown.
- Bend heating cable and work it through opening in braid.
- Remove insulation from ends of bus wires.
- Pull braid tight to make pigtail.

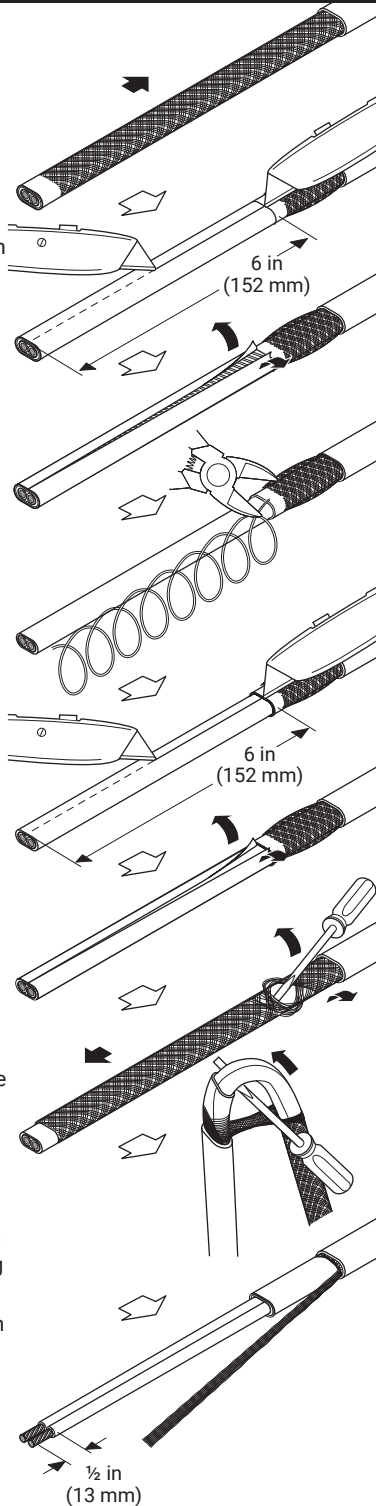

Go to Step 6

5D

HTV

- Push braid back to create a pucker.
- At pucker use a screwdriver to open braid.
- Bend heating cable and work it through opening in braid.
- Score inner jacket and conductive core around and down as shown.
- Peel off inner jacket.
- Flip the cable 180° and score the other side of inner jacket and conductive core.
- Remove the inner jacket, conductive core by using needle-nose pliers as shown.
- Score and remove center insulation.
- Remove any remaining material from bus wires.
- Pull braid tight to make pigtail.

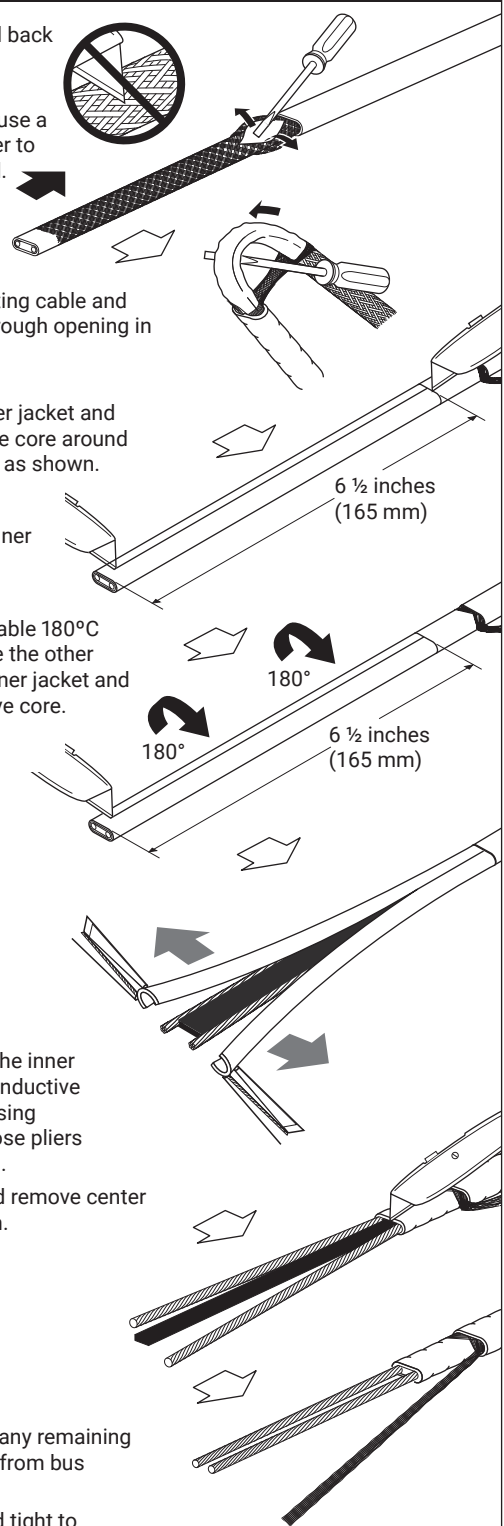

Go to Step 6

**6**

- Mark the jacket as shown.

5/8 in (15 mm)

**7**

**⚠ CAUTION: Health Hazard. Wash hands after contact with sealant in core sealer. Consult material safety data sheet VEN 0058.**

**⚠ AVERTISSEMENT : risque pour la santé. Se laver les mains après tout contact avec le produit d'étanchéité. Consulter la fiche de données de sécurité VEN 0058.**

- If needed, re-twist and straighten bus wires, then insert into the guide tubes as shown.

**Make sure all strands go into the tubes.**

Tubes

**8**

- Push core sealer onto the heating cable to the mark made in step 6.

**Note:** Extra force may be required for larger cables or at lower temperatures.

**Make sure the bus wires do not kink, bunch, or crossover.**

**9**

- Remove the guide tubes and dispose of them in a plastic bag.
- Slip the green/yellow tube onto the braid. Heat-shrinking is not required.

**10**

- Trim bus wires and braid.

1/2 in (13 mm)

1/2 in (13 mm)

**11**

- Pull heating cable back into stand so 1 in (25 mm) is exposed as shown. Use cable lubricant if needed.

1 in (25 mm)



12

- Fasten stand to pipe with label facing desired direction of box opening. Do not pinch heating cable.
- Loop and tape extra heating cable to pipe.

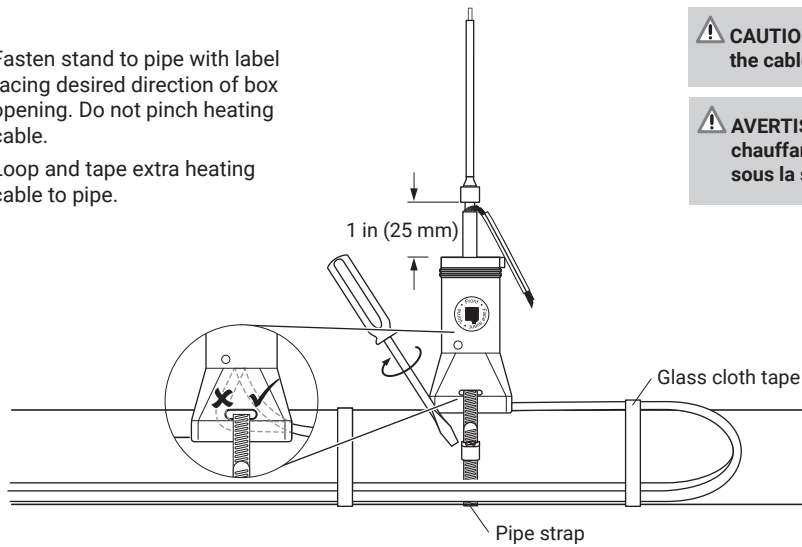

**CAUTION:** To avoid pinching the heating cable, be sure the cable is not under the pipe strap.

**AVERTISSEMENT :** Pour éviter de pincer le câble chauffant, assurez-vous que le câble ne se trouve pas sous la sangle du tuyau.

12A

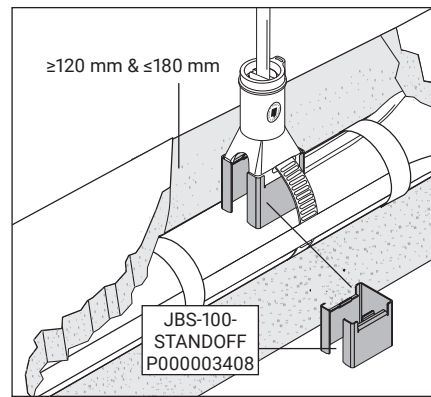
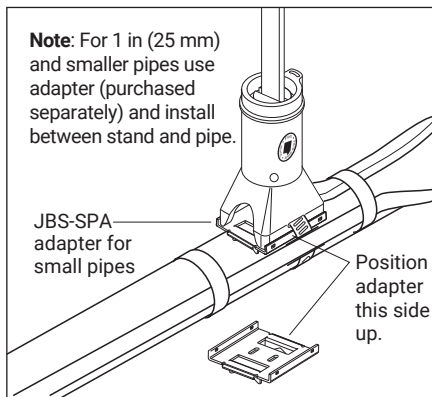

13

- Screw box onto stand until it stops. Do not overtighten.

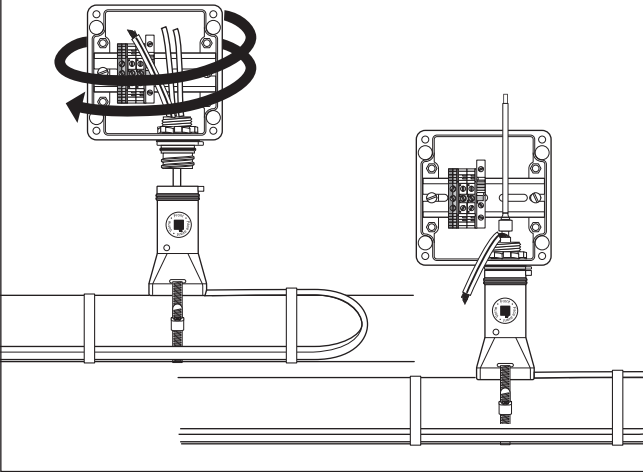

14

**(Optional) To change direction of box opening:**

- Loosen locknut.
- Lift box and rotate. Make sure tab on threaded piece fits into one of the four notches in box.
- Tighten locknut.

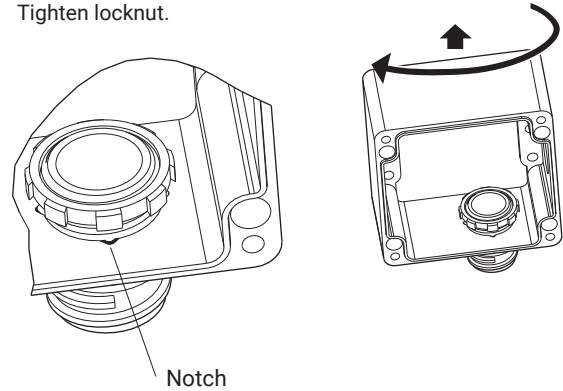

15

- Insert cable tie through slots on stand and box, and tighten firmly to prevent box rotation.

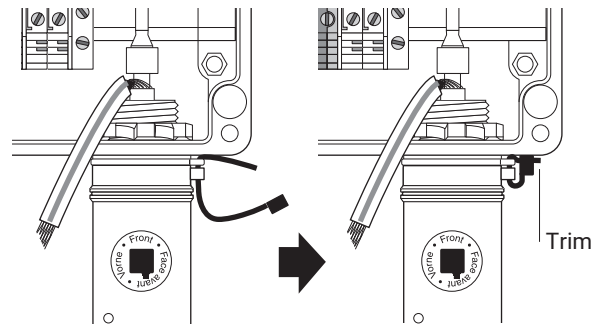

This kit uses screw style terminals.

To connect wires, fully insert into opening on side of terminal block ①. Insert small flat-blade screwdriver through round opening and firmly tighten screw ②.

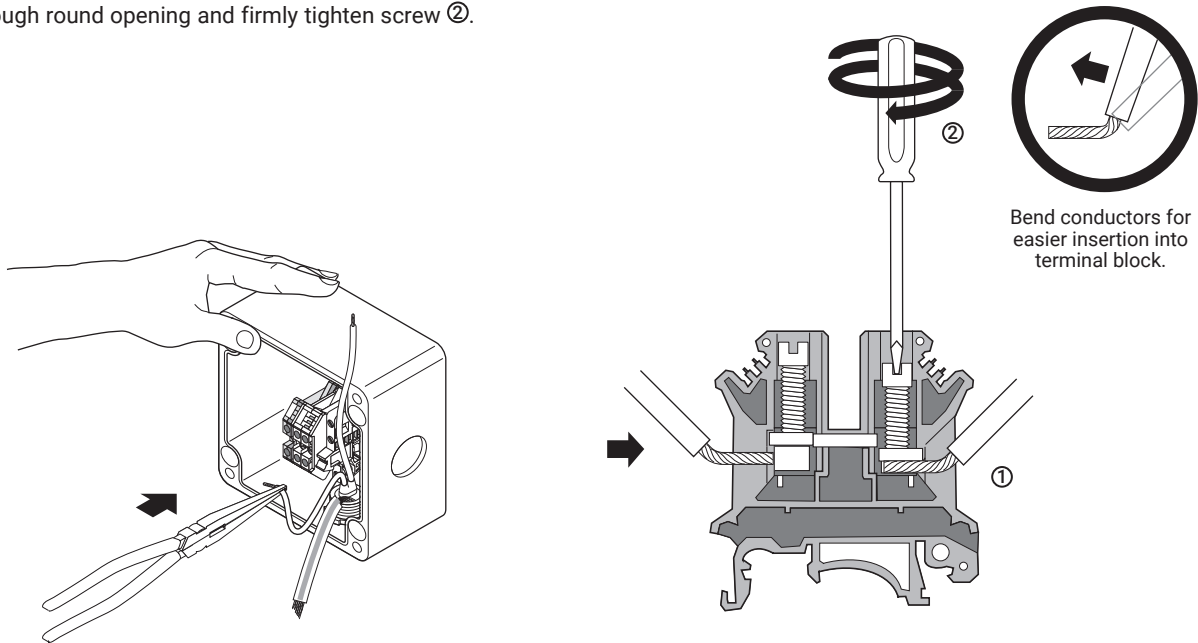

- Wire insertion ①.
- Use green terminal for braid and ground wire.

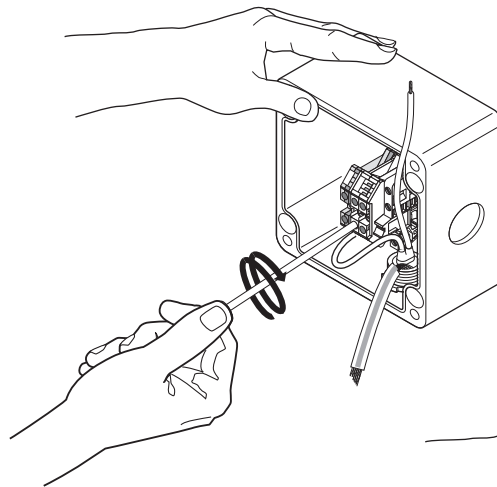

- Tighten screws ②.

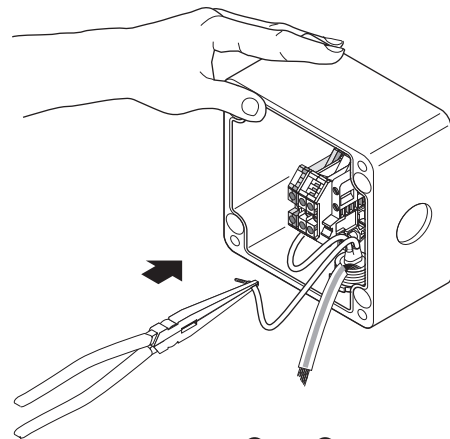

- Repeat ① and ② for remaining wires.

17

- Install conduit and fittings as shown. To minimize loosening due to pipe vibration, use flexible conduit.
- Pull in power and ground wires, strip off ½ in (13 mm) of insulation and terminate.

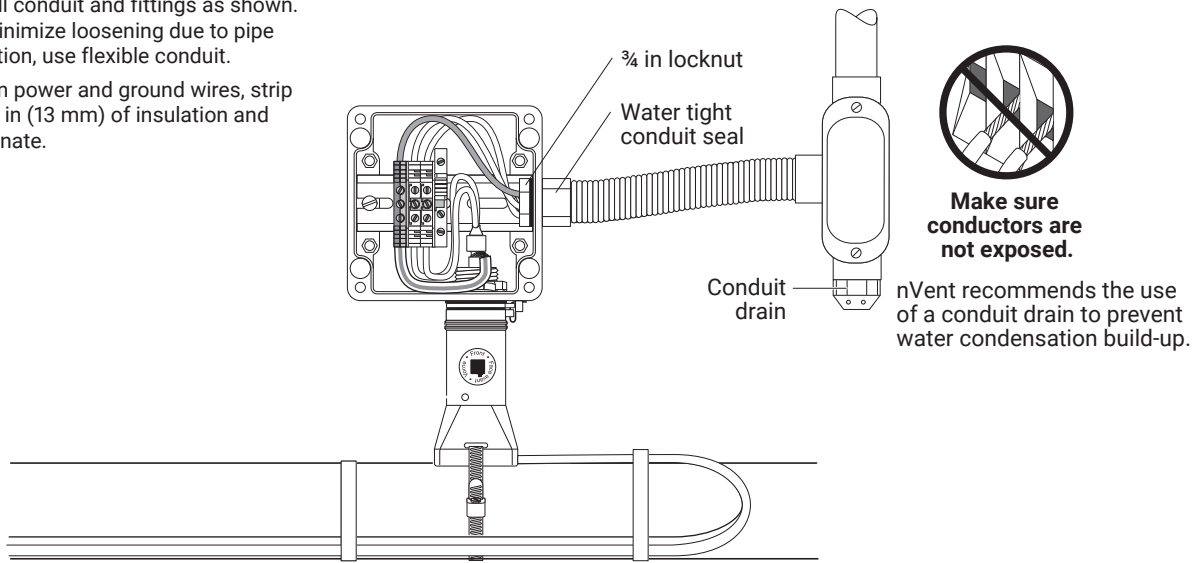

18

- Install lid. Torque = 1.02 to 1.47 Nm
- Apply insulation and cladding.
- Weather-seal the stand entry.
- Leave these instructions with the end user for future reference.

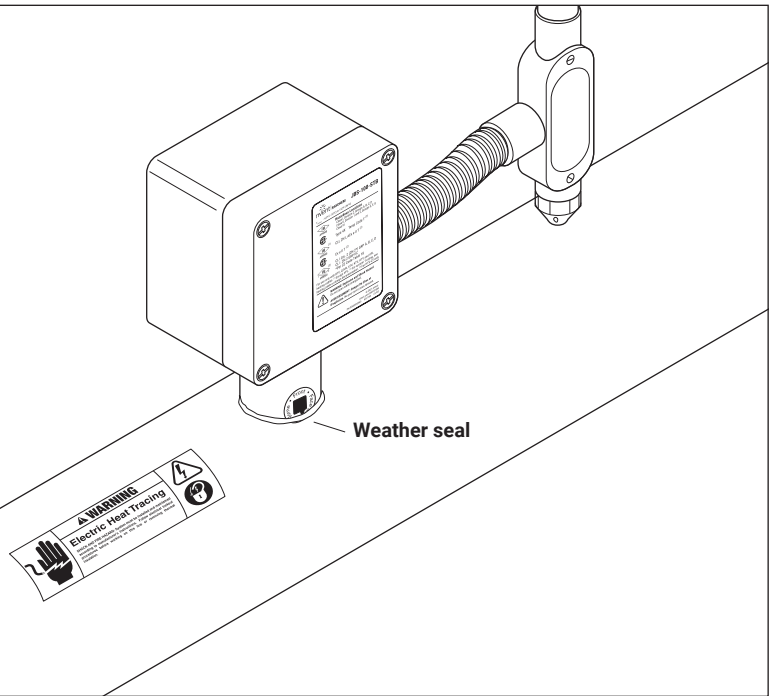

**⚠ WARNING: EXPLOSION HAZARD- SUBSTITUTION OF COMPONENTS MAY IMPAIR SUITABILITY FOR CLASS I DIVISION 2 (Zone 2)**

**⚠ WARNING: EXPLOSION HAZARD- DO NOT DISCONNECT EQUIPMENT UNLESS POWER HAS BEEN SWITCHED OFF OR THE AREA IS KNOWN TO BE NON-HAZARDOUS.**

**⚠ AVERTISSEMENT: RISQUE D'EXPLOSION. LA SUBSTITUTION DE COMPOSANTS PEUT RENDRE CE MATÉRIEL INACCEPTABLE POUR LES EMPLACEMENTS DE CLASSE I, DIVISION 2 (Zone 2).**

**⚠ AVERTISSEMENT: RISQUE D'EXPLOSION. NE PAS DÉBRANCHER L'APPAREIL À MOINS D'AVOIR COUPÉ L'ALIMENTATION ÉLECTRIQUE OU À MOINS QU'IL NE S'AGISSE D'UN EMPLACEMENT NON DANGEREUX**

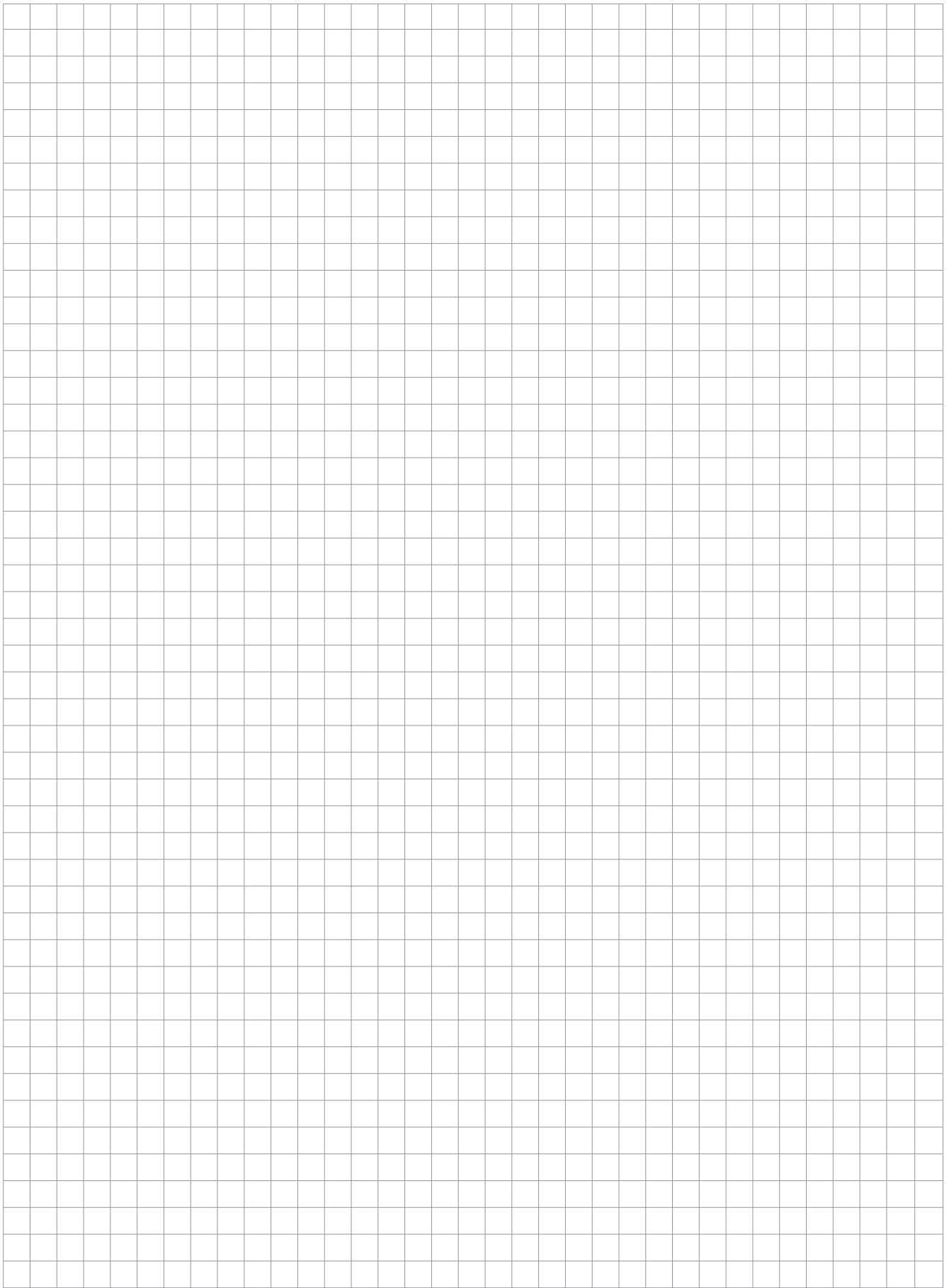

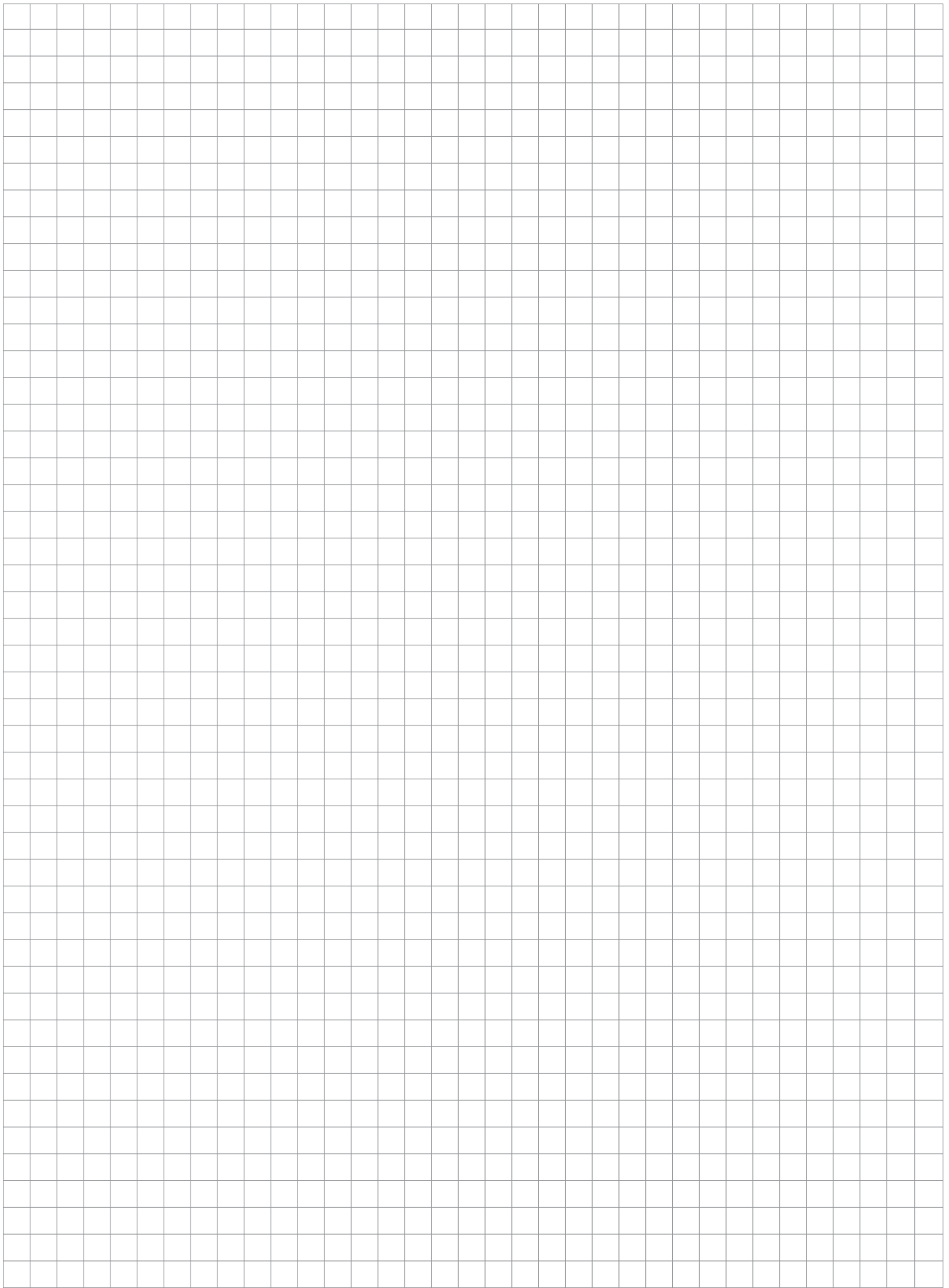

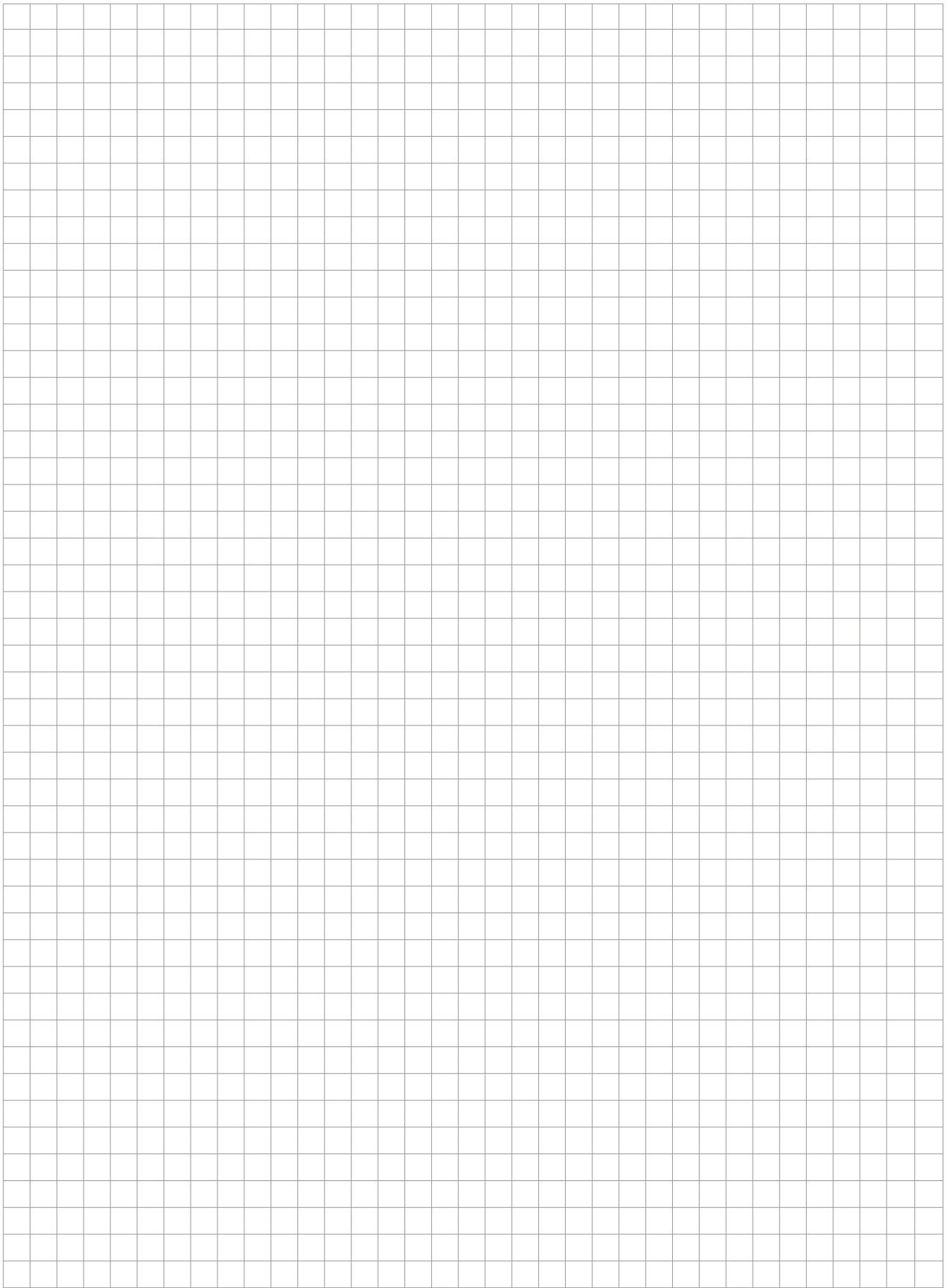

**North America**

Tel +1.800.545.6258  
Fax +1.800.527.5703  
thermal.info@nVent.com

**Europe, Middle East, Africa**

Tel +32.16.213.511  
Fax +32.16.213.604  
thermal.info@nVent.com

**Asia Pacific**

Tel +86.21.2412.1688  
Fax +86.21.5426.3167  
cn.thermal.info@nVent.com

**Latin America**

Tel +1.713.868.4800  
Fax +1.713.868.2333  
thermal.info@nVent.com



[nVent.com/RAYCHEM](https://www.nVent.com/RAYCHEM)