

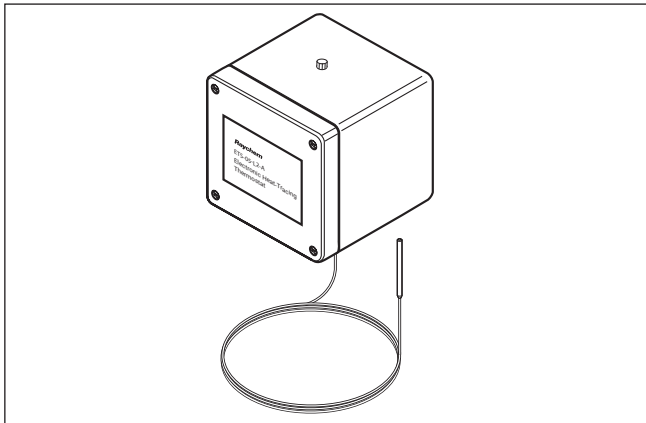

RAYCHEM

ETS-05

Electronic thermostat



APPROVALS

FM Approvals:

CL I, ZN 1 AEx e ia mb IIC T5 Gb
Zone 21 AEx tb IIIC T100°C

Ex e ia mb IIC T5 Gb
Ex tb IIIC T100°C Db

CL I, DIV 2, Groups B, C, D

CL II, DIV 2, Groups E, F, G

CL III

TYPE 4X/IP66

Maximum Service Temperature: 125°C (257°F)

Minimum Service Temperature: -40°C (-40°F)

Ambient Temperature Range: -40C to 60C (-40F to 140F)



ETS-05 THERMOSTAT CONTENTS

Qty	Description
1	Thermostat enclosure
2	Cable entries (3/4")
1	Temperature sensor terminals
1	Power and Heat Tracing Terminal Blocks max. 10AWG (6 mm ²)

DESCRIPTION

The nVent RAYCHEM ETS-05 electronic surface sensing thermostat provides accurate temperature control for heating cables. The ETS-05 is available in two versions. The ETS-05-L is for temperatures up to 199°C (390°F), while the ETS-05-H can be used for sensing and control of temperatures up to 499°C (930°F). The maximum nominal load is 24 A for both thermostats. Temperature setting is accurate via digital rotary switches inside the enclosure.

The ETS-05 has a LED indicator which indicates the status of the thermostat (powered on/off), the status of the heat-tracing cable (powered on/off) and the status of the sensor. In case of sensor failure the thermostat can switch to an on or off state, depending upon the users requirement.

The ETS-05 is available in the following versions:

ETS-05	Mount/Box	Voltage
ETS-05-L1-A	pipe/wall, deep	99-132 VAC -10% 50/60 Hz
ETS-05-L2-A	pipe/wall, deep	195-277 VAC -2.5% 50/60 Hz, Um=277V
ETS-05-H1-A	wall/bracket, deep	99-132 VAC -10% 50/60 Hz
ETS-05-H2-A	wall/bracket, deep	195-277 VAC -2.5% 50/60 Hz Um=277V

For technical support call nVent.

TOOLS REQUIRED

- Terminal Screwdriver
- Flat Screwdriver
- Trimming Knife

MATERIALS REQUIRED

- Certified glands suitable for use with the thermostat enclosure

WARNING:

This component must be installed correctly to ensure proper operation and to prevent shock or fire. Read these important warnings and carefully follow all of the installation instructions.

- To minimize the danger of fire from sustained electrical arcing if the heating cable is damaged or improperly installed, and to comply with the requirements of nVent, agency certifications, and the National Electrical Code, ground-

fault equipment protection must be used. Arcing may not be stopped by conventional circuit breakers.

- Component approvals and performance are based on the use of nVent-specified parts only. Do not use substitute parts or vinyl electrical tape.
- The black heating cable core and fibers are conductive and can short. They must be properly insulated and kept dry.

- Damaged bus wires can overheat or short. Do not break bus wire strands when scoring the jacket or core.
- Keep components and heating cable ends dry before and during installation.
- Use only fire resistant insulation materials, such as fiberglass wrap or flame-retardant foam.

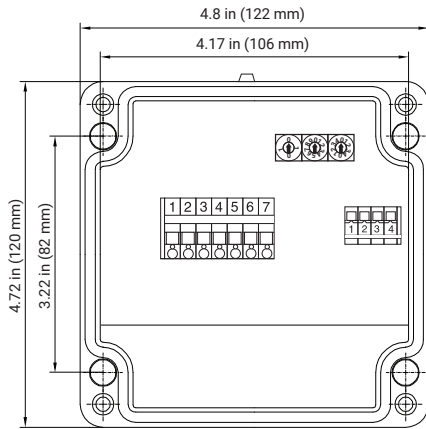

TERMINAL BLOCK

1	2	3	4	5	6	7
Relay Out	Neutral Out	Neutral Supply	Line Supply	Earth	Earth	Earth

Terminals 2 and 3 are joined electrically
 Terminals 5, 6 and 7 are joined electrically

*NOTE: Do not remove Earth connecting wire

SENSOR/FAILURE MODE SELECT TERMINALS

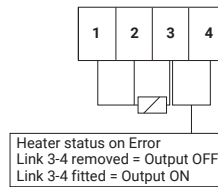

Terminals 1 to 3 allow for the connection of a three wire PT100 sensor.

Terminals 3 to 4 allow the user to select the default heating status on sensor error.

Without a link fitted the output will turn OFF if a sensor error is detected.

With a link fitted the output will turn ON if a sensor error is detected (default).

1

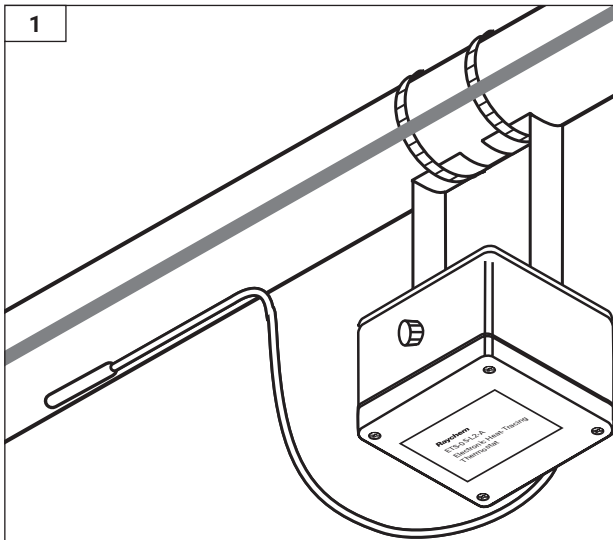

Enclosure Installation RAYCHEM ETS-05 Thermostat (For Pipe Stand Installation please refer to H59250)

- The heating cable can be directly terminated to the thermostat without an intermediate junction box using the nVent RAYCHEM C75-100-A or HAK-C-100 connection kits. Only the unheated section of the heater (cold lead) may protrude into the thermostat enclosure.
- Alternative mounting arrangements are illustrated (4 mounting holes, 17/64" dia (M6) clearance at 4.2" x 3.2" (106 x 82 mm).
- For optimized temperature control install the unit remote from sensor bulb. Locate enclosure at appropriate place to avoid exposure to mechanical and thermal damage (do not mount on pipe for high temperatures).

⚠ WARNING: When working in damp or wet conditions protect the thermostat contents from water ingress by closing lid when not working on the assembly.

2

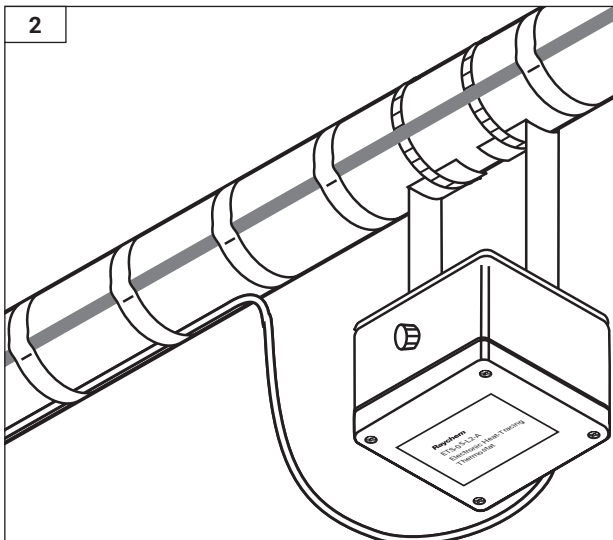

Location of the sensor RAYCHEM ETS-05 (when equipped)

- As indicated in the system design documentation.
- Away from valves, flanges, supports, pumps, or other heat sinks.
- At the top of the pipe for thermally sensitive pipe contents (A).
- On lower quadrant of pipe 90° for single heating cable (B).
- On lower quadrant of pipe centrally between the heating cables if there are two or more (C).

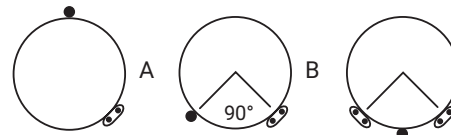

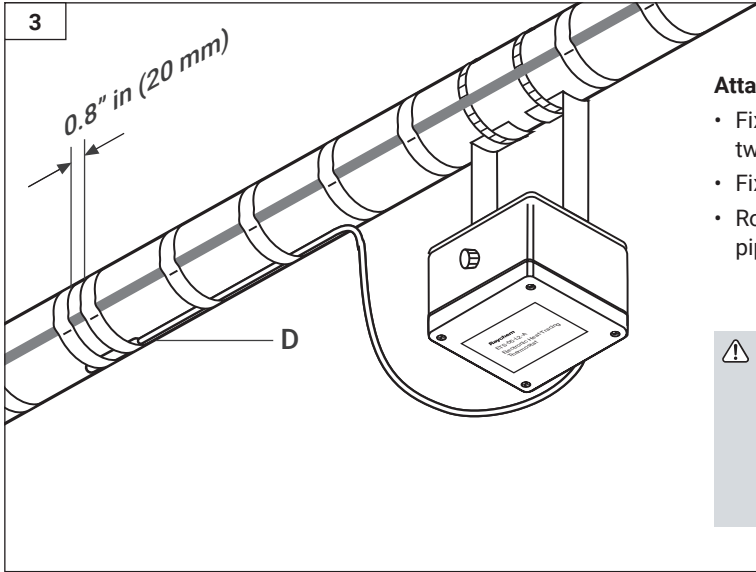

Attachment of the sensor RAYCHEM ETS-05

- Fix sensor firmly on surface with adequate fixing tape in two places (D)
- Fix sensor parallel to pipe (D)
- Route extension cable to avoid damage in use. Fix to pipe with adequate tape where appropriate.

⚠ WARNING: Do not install sensor at ambient temperatures below -4°F (-20°C). Do not bend sensor (last 2 in / 50 mm), keep it straight under all circumstances. Minimum bending radius for High Temperature Mineral Insulated Sensor extension cable: 6x diameter.

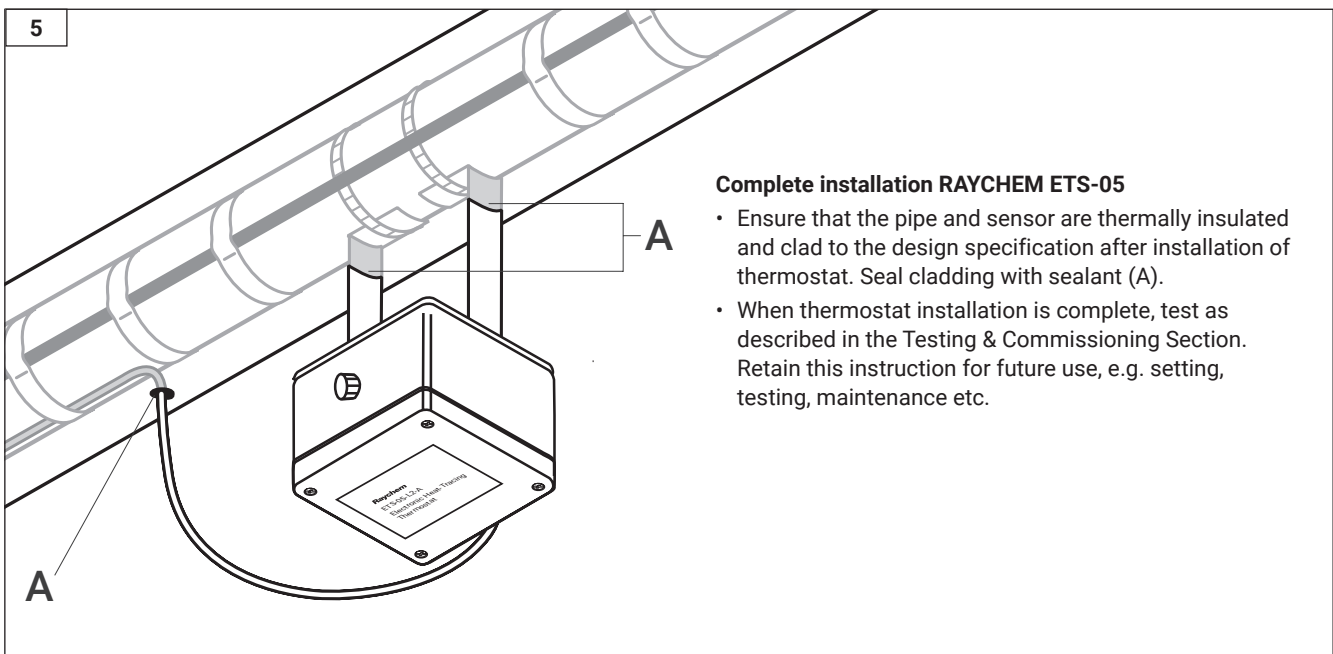
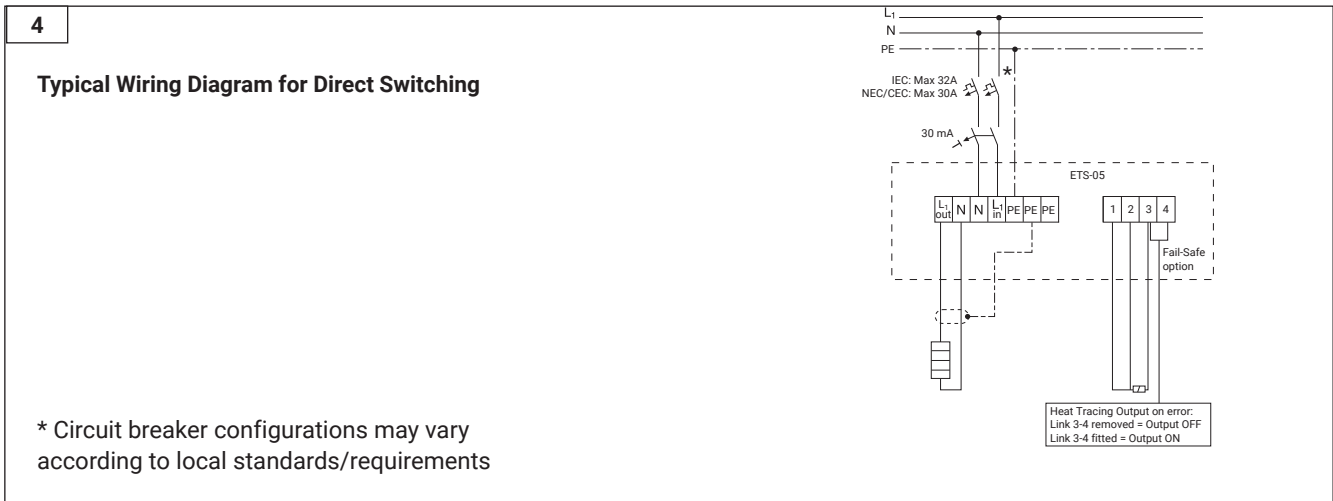

Setting

- If necessary, loosen lid screws and remove lid. Adjust digital switches to switching temperature (°C). Locate lid and tighten lid screws.

⚠ WARNING: Ensure thermostat is isolated elsewhere for a minimum of 1 minute before opening.

Note: Temperature setpoint is in °C. To convert °F to °C use the formula $(°F - 32) \times 0.56$ "

ETS-05-Lx

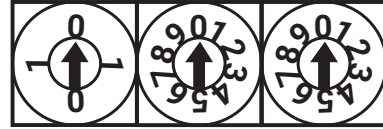

ETS-05-Hx

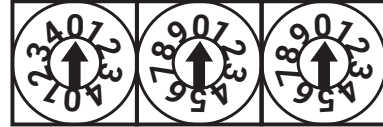
**Testing, Commissioning, and Maintenance**

Test heating cable when thermostat installation is complete as directed in RAYCHEM Installation and Maintenance manual. Maintain thermostat during normal plant maintenance.

CHECK:

- Mounting is firm
- Exposed extension cable is not damaged
- Gland sealing washer is in place
- Gland seal (grommet) is in place.
- Gland body and nut(s) are tightened firmly.
- Thermostat operation is correct.
- Thermostat setting suits application.
- Lid is closed firmly.
- Cable type is correct (Insulation > 277 V and temperature rating to suit application) - Note: Cable gland heatrise could reach 30K.
- Not more than one conductor may be connected into power terminal block without the use of a single insulated bootlace ferrule.

North America

Tel +1.800.545.6258
Fax +1.800.527.5703
thermal.info@nvent.com

Europe, Middle East, Africa

Tel +32.16.213.511
Fax +32.16.213.604
thermal.info@nvent.com

Asia Pacific

Tel +86.21.2412.1688
Fax +86.21.5426.3167
cn.thermal.info@nvent.com

Latin America

Tel +1.713.868.4800
Fax +1.713.868.2333
thermal.info@nvent.com



nVent.com