

Mineral Insulated Heating Cables



RAYCHEM

CONNECT AND PROTECT

This section provides an overview and general design guidelines for nVent RAYCHEM mineral insulated (MI) heat tracing systems. For complete design assistance, contact your nVent representative or visit our website at nVent.com/RAYCHEM.

Contents

INTRODUCTION	1
Typical Applications	2
Mineral Insulated Heating Cable Construction	2
SYSTEM OVERVIEW	3
Typical Mineral Insulated Heating Cable System	3
Ground-Fault Protection	4
Approvals and Certifications	4
THERMAL DESIGN AND HEATING CABLE SELECTION	5
BILL OF MATERIALS	13
Heating Cable Set Catalog Number	13
Selection of Connection Kits and Accessories	14

INTRODUCTION

Mineral insulated cables are mechanically robust and durable. They are ideally suited to harsh environments and applications.

Mineral insulated heating cables offer a wide variety of solutions for industrial heat-tracing applications. MI heating cables are series-type heating cables and suitable for maintain temperatures up to 1022°F (550°C) and exposure temperatures up to 1200°F (650°C). MI heating cable is the ideal choice when an application's temperature and power output requirements exceed the capabilities of self-regulating and power-limiting heating cables.

MI heating cables can be used for applications with the following requirements:

- Maintain temperature up to 1022°F (550°C)
- Power output to 61 W/ft (200 W/m)
- Maximum heating cable exposure temperature to 1200°F (650°C)

Higher temperature and power capabilities are available; contact nVent for additional information.

TYPICAL APPLICATIONS FOR MI HEATING CABLES ARE LISTED IN TABLE 1.

TABLE 1 EXAMPLES OF MI HEATING CABLE APPLICATIONS

Refining crude distillation	Chemical and petrochemical	Power generation
Hydrocracking	Phthalic anhydride	High-pressure feedwater
Coking	Benzene	Blowdown lines
Wax	Styrene	Instrument lines
Sulphur	Propylene glycol	Steam lines
Asphalt	Ethylene glycol	De-aerator lines
Heavy residue	Polyethylene	High-pressure condensate
Gas condensate prevention	Polypropylene	
Bitumen	Chlorine	
	Acrylic acid	
	Adipic acid	
	Dimethyl terephthalate	
	Synthetic fiber polymers	
	Nylon monomer	
	Paints and resins	

Mineral Insulated Heating Cable Construction

XMI-A HEATING CABLES

nVent RAYCHEM XMI-A heating cables consist of one or two conductors embedded in a highly dielectric magnesium oxide insulation surrounded by a metal sheath of Alloy 825. This nickel alloy is recognized for its high temperature service and resistance to pitting, acid, salt, and alkali corrosion. In addition, Alloy 825 provides excellent protection against stress corrosion cracking and has a long history of success in heat-tracing applications, particularly at high temperatures.

XMI-A heating cables provide superior strength in dynamic cut-through, crush, and corrosion tests. Special annealing processes maximize flexibility for ease of on-site handling.

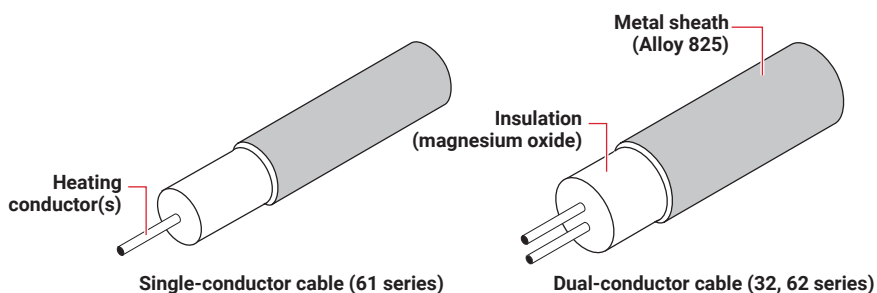

Fig. 1 XMI-A Single- and dual-conductor cables

XMI-L HEATING CABLES

Where Auto Ignition Temperature (AIT) constraints drive heating cable design to multiple passes of cable on equipment due to sheath temperature limitations, this can lead to field construction issues. Insufficient space is available on the equipment to apply the required number of passes.

XMI-L heating cable has been specially developed to mitigate challenging applications of this nature.

Conventional nVent RAYCHEM MI cable is sealed inside a corrugated 316L stainless steel sheath which dramatically increases surface area and results in lower sheath temperatures. This results in a reduction in the number of passes of cable required and correspondingly fewer construction issues.

XMI-L heating cables are supplied in two conductor configurations.

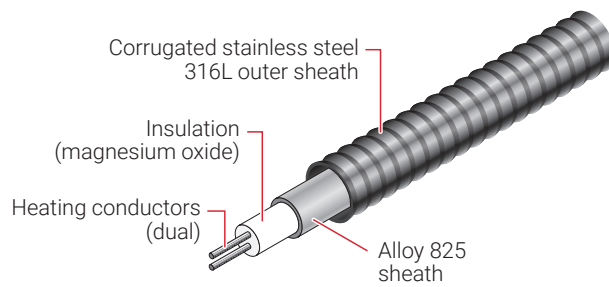

Fig. 2 XMI-L Dual conductor cables

Note: Dual conductor cable (32,62 series)

MI heating cable sets are supplied factory terminated and ready to install. They include a heating section and a nonheating cold lead section.



Design D: Dual conductor cable (32, 62 series only)

Fig. 3 Typical MI heating cable set (dual conductor)

SYSTEM OVERVIEW

Typical Mineral Insulated Heating Cable System

A typical MI heating cable system is shown in Fig. 4. Unlike self-regulating or power-limiting cables, MI heating cables are supplied in fixed lengths, so determining and ordering the correct cable length is critical. The heating cable is attached to the pipe with metal banding or tie wire. The cold lead cable is connected to a junction box, which in turn is connected to the power supply.

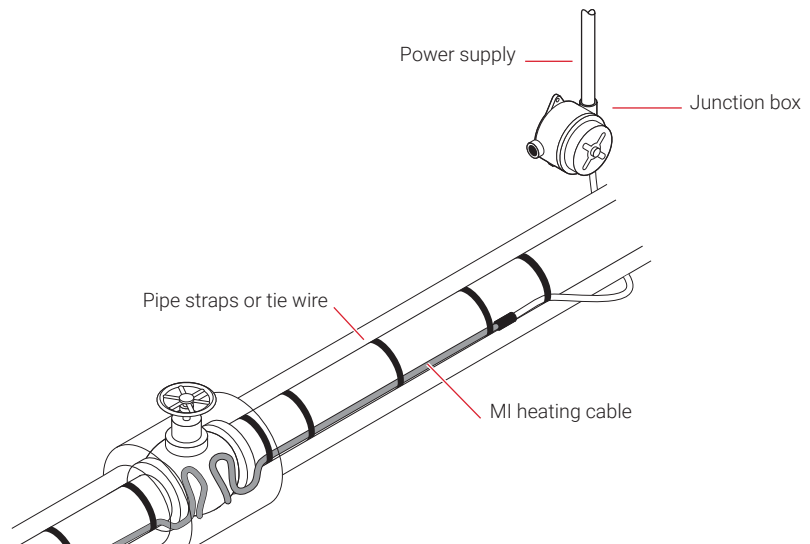

Fig. 4 Typical mineral insulated heating cable system

Ground-Fault Protection

To minimize the danger of fire from sustained electrical arcing if the heating cable is damaged or improperly installed, and to comply with the requirements of agency certifications and national electrical codes, ground-fault equipment protection must be used on each heating cable branch circuit.

Approvals and Certifications

nVent RAYCHEM mineral insulated systems are approved and certified for use in non-hazardous and hazardous locations by many agencies. Please refer to the technical datasheets (XMI-A-H56870, XMI-L-H59079 and Cold lead options-H59126) for more details.

The following steps illustrate the process for designing a mineral insulated heat-tracing system. For a complete design, you must use TraceCalc Pro design software or contact nVent for design assistance. nVent RAYCHEM TraceCalc Pro design software may be downloaded after registering at nVent.com/RAYCHEM. Use the Heat-Tracing Design Request Form (H56893) to submit the required data for your application.

- 1** The heating cable selection process involves four basic steps:
- 2** Gather the necessary information.
- 3** Determine the power output and heating cable length.
- 4** Select the heating cable design configuration.
- 5** Select the heating cable type, reference, and cold lead.

Example: The example carried through this section shows a simple freeze protection application for a high-pressure condensate line in a power plant. It is simplified, but shows the basic principles of an MI series resistance heating cable design.

Thermal Design
1. Gather information
2. Calculate temperature differential
3. Calculate heat loss
4. Compensate for insulation type

Step 1 Gather the necessary information

- Pipe size and material_____
- Insulation type and thickness_____
- Maintain temperature (T_M)_____
- Minimum ambient temperature (T_A)_____
- Service voltage (V)_____
- Maximum exposure temperature_____
- Area classification_____
- Pipe length (L)_____
- Number of pipe supports_____
- Number and size of valves_____

Example: Gather information

- Pipe size and material: 1-inch steel pipe
- Insulation type and thickness: 1/2-inch glass fiber
- Maintain temperature: 40°F
- Minimum ambient temperature: 0°F
- Service voltage: 120 V
- Maximum exposure temperature: 680°F
- Area classification: Nonhazardous
- Pipe length: 80 ft
- Pipe supports: Thermally insulated
(already insulated; excluded from example calculations)
- Valves: 2 x 1-inch light valves (threaded)

Thermal Design
1. Gather information
2. Calculate temperature differential
3. Calculate heat loss
4. Compensate for insulation type

Step 2 Determine the pipe heat loss and total heating cable length

THERMAL DESIGN (REQUIRED POWER OUTPUT)

To select the proper heating cable, first calculate the pipe heat loss for your application as outlined in Section 1, the nVent RAYCHEM Self-Regulating Cables design guide (H56822). For applications with higher maintain temperatures, use TraceCalc Pro design software or contact your nVent representative.

Example: MI heating cable is required because of the high maximum exposure temperature.

Pipe heat loss: $P = 3.5 \text{ W/ft} \times 40/50 = 2.8 \text{ W/ft} (9.2 \text{ W/m})$
from the Self-Regulating Cables design guide (H56822)

TOTAL HEATING CABLE LENGTH

The total length of the MI heating cable (L) needs to accommodate pipe length and additional cable required to compensate for heat loss of valves and supports, as well as an installation allowance for field variances (see Table 2).

The length of the heating cable can be determined by using Table 2 and the following worksheet. For small pipes or applications with low power requirements, a single run of two conductor heating cable will often be sufficient. For larger pipes or higher temperatures, multiple runs of single or two conductor heating cable may be required. It is recommended that the design and cable selection process start by assuming a single run of cable and only increase the number of runs if no satisfactory solution can be found.

Depending on the complexity of the application, Steps 2 through 4 can be an iterative process. We recommend using TraceCalc Pro design software. Contact your nVent representative for assistance.

TABLE 2 TYPICAL ALLOWANCES PER RUN OF CABLE (FT)

NPS	Light valve (flanged)	Light valve (threaded or welded)	Heavy valve (flanged)	Heavy valve (threaded or welded)	Typical pipe shoe	150lb Flange (pair)	Field variance
0.5"	1	1	1	1	3	0.6	2%
0.75"	1.5	1	1.5	1	3	0.6	2%
1"	2	1	2	1	3	0.6	2%
1.5"	2.5	1.5	3	1.5	3	0.6	2%
2"	2.5	2	3.5	2	3	0.8	2%
3"	3	2.5	4	2.5	3	0.8	3%
4"	4	3	5	3	3	0.9	3%
6"	5	3.5	6	3.5	3	0.9	3%
8"	7	4	8	4	3	1.0	3%
10"	8	5	10	5	3	1.1	3%
12"	9	6	12	6	3	1.3	3%
14"	10	7	14	7	4.5	1.5	3%
16"	10.5	8	15	8	4.5	1.6	3%
18"	11	9	15.5	9	4.5	1.7	3%
20"	11	10	16	10	4.5	1.8	3%
24"	11.5	12	17	12	4.5	1.9	3%

5. "Light valve" refers to 150 lb valves; "heavy valve" refers to 300 lb valves. For other fittings and support, contact nVent.

6. Allowances above are based on typically available fittings and supports, with insulation that is equivalent to the pipe insulation.

7. For pipes requiring more than two runs of heating cable, apply the full allowance for each run of cable on each fitting or support as long as space allows. However, MI heating cables must not touch or overlap. The minimum spacing between cables is 1" (25 mm). Contact nVent if more than two runs are needed or if cable spacing is less than 1" (25 mm).

8. For some applications, it may be physically impossible to install all of the recommended heating cable directly on the fitting or support. In this case, install the excess heating cable on the pipe, on either side of the fitting or support, or eliminate the additional heater length from your length calculation if a lower local temperature is acceptable. This constraint may be difficult for small pipes and/or multiple cable runs. If required, contact nVent for assistance.

WORKSHEET TO DETERMINE TOTAL HEATING CABLE LENGTH

Example input from Steps 1 and 2.

Pipe size	<u>1"</u>	Pipe length	<u>80</u> ft	x 1.02 or 1.03* =	<u>81.6</u> ft
#	<u>2</u>	<u>1"</u> Valves	@	<u>1</u> ft	= <u>2</u> ft
#	<u> </u>	Valves	@	<u> </u> ft	= <u> </u> ft
#	<u> </u>	Supports	@	<u> </u> ft	= <u> </u> ft
#	<u> </u>	Supports	@	<u> </u> ft	= <u> </u> ft
		Other heat sinks	<u> </u> ft	=	<u> </u> ft
		Sum of the above		=	<u>83.6</u> ft
		Multiply by no. of runs of heating cable	<u>1</u> x	=	<u>83.6</u> ft
		Equals total heating cable length (L), rounded:			<u>84</u> ft

* Field variance from Table 3.2

Thermal Design
1. Gather information
2. Calculate temperature differential
3. Calculate heat loss
4. Compensate for insulation type

Step 3 Select the heating cable design configuration

The MI heating cable sets are factory terminated in the four design configurations shown below. They are supplied with the heated section joined to a length of nonheating cold lead section, preterminated and ready to fasten in a junction box with an NPT-threaded connector.

Note: XMI-L available in D or E configurations only.

Design A



Design A: Single conductor cable (61 series only)

Design B

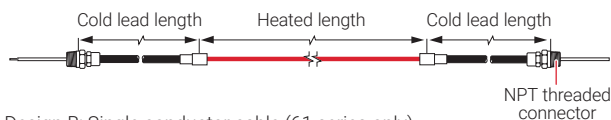

Design B: Single conductor cable (61 series only)

Design D

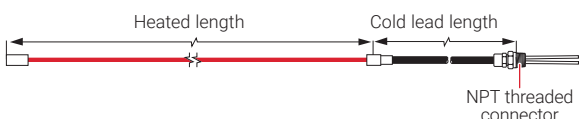

Design D: Dual conductor cable (32, 62 series only)

Design E

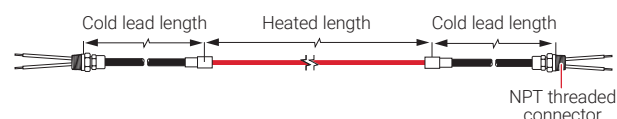

Design E: Dual conductor cable (32, 62 series only)

Fig. 5 XMI-A Heating cable design configurations

For a single run of heating cable, Design D is the most economical solution.

Example: Select Design D for a single run of dual conductor cable.

Thermal Design
1. Gather information
2. Calculate temperature differential
3. Calculate heat loss
4. Compensate for insulation type

Step 4 Select the heating cable type, reference, and cold lead

Heating cable types are listed in Table 3.

TABLE 3 MI HEATING CABLE TYPES

Specifications	Series 61	Series 32	Series 62
Number of conductors	1 – single	2 – dual	2 – dual
Maximum operating voltage	600 V	300 V	600 V
Reference table	5	6	7

Note: See datasheet H59079 for XMI-L heating cable types, voltages and conduit sizing options in the event that multiple pass construction issues arise from design using XMI-A.

Table 5, Table 6, and Table 7 list the resistances available for the XMI-A heating cable types.

The naming convention of the heating cables is described in Table 4.

TABLE 4 HEATING CABLE REFERENCE

Digit number	Description
1	Maximum voltage rating 3 = 300 V, 6 = 600 V
2	Number of conductors 1 or 2
3	Sheath material S = Alloy 825
4	Conductor material A, B, C, F, P, Q, or T
5	Move decimal point to left indicated number of places 1, 2, 3, 4, 5, or 6 places
6 to 8	Cable resistance to three whole numbers (use with digit 5) 2200 = 2.00 Ω/cable foot at 20°C

nVent RAYCHEM Copper-sheathed MI heating cables for low temperature applications are available upon request.

Sample reference:
6 2 S F 2 2 0 0
Digit 1 2 3 4 5 6 7 8

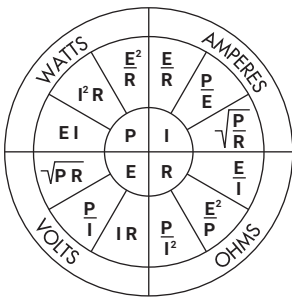

Ohm's Law Formulas

P = Power (W)
I = Current (A)
E = Electromotive Force (V)
R = Resistance (Ω)

To select the heating cable reference, calculate the maximum resistance that the cable can have in order to supply the required power using Ohms law:

$$R_{\max} = V^2 / (P_{\min} \times L^2)$$

R_{\max} : Maximum cable resistance to meet power requirement [Ω/ft or Ω/m]

V : Voltage across heating element [V]

P_{\min} : Required power output [W/ft or W/m]

L : Total heating cable length [ft or m]

The minimum required power output (P_{\min}) must be at least equal to the heat loss (P) determined in Step 2.

Example: $P_{\min} = P = 2.8 \text{ W/ft}$ (from Step 2)
 $R_{\max} = (120 \text{ V})^2 / (2.8 \text{ W/ft} \times (84 \text{ ft})^2) = 0.7289 \text{ Ω/ft}$ (2.39 Ω/m)

Now select a heating cable with a nominal resistance lower or equal to this maximum resistance from Table 6. Start by using a 300 V dual conductor cable (32 series) for the most economical solution.

Example: From Table 6 select cable 32SB3700 $R_{\text{nom}} = 0.700 \text{ Ω/ft}$ (2.30 Ω/m)

Note: Table 5, Table 6, and Table 7 show the nominal conductor resistance; tolerance is ± 10%.

TABLE 5 SERIES 61 MI HEATING CABLE SPECIFICATIONS (600 V, SINGLE CONDUCTOR)

Heating cable reference	Nominal cable resistance at 20°C		Approximate cable diameter		Maximum unjointed cable length		Nominal weight	
	Ω/ft	Ω/m	in	mm	ft	m	lb/1000 ft	kg/1000 m
61SA2200	2.00	6.56	0.170	4.3	1333	406	50	75
61SA2160	1.60	5.25	0.163	4.1	1452	443	44	66
61SA2130	1.30	4.27	0.160	4.1	1508	460	42	63
61SA2100	1.00	3.28	0.160	4.1	1510	460	43	64
61SA3850	0.850	2.79	0.170	4.3	1338	408	48	72
61SA3700	0.700	2.30	0.160	4.1	1514	462	43	64
61SA3500	0.500	1.64	0.170	4.3	1344	410	49	73
61ST3280	0.280	0.919	0.170	4.3	1337	408	48	72
61SB3200	0.200	0.656	0.180	4.6	1198	365	55	82
61SB3150	0.150	0.492	0.170	4.3	1350	412	51	76
61SQ3118	0.118	0.387	0.175	4.4	1260	384	50	75
61SQ4732	0.0732	0.240	0.170	4.3	1338	410	48	72
61SQ4581	0.0581	0.191	0.172	4.4	1308	399	50	75
61SP4467	0.0467	0.153	0.170	4.3	1337	408	48	72
61SP4366	0.0366	0.120	0.173	4.4	1292	394	50	75
61SP4290	0.0290	0.0951	0.177	4.5	1236	377	53	79
61SP4231	0.0231	0.0758	0.174	4.4	1282	391	52	78
61SP4183	0.0183	0.0600	0.170	4.3	1347	411	50	75
61SP4145	0.0145	0.0476	0.170	4.3	1351	412	51	76
61SP4113	0.0113	0.0371	0.186	4.7	1130	345	61	91
61SC5651	0.00651	0.0214	0.187	4.7	1110	338	60	89
61SC5409	0.00409	0.0134	0.191	4.9	1069	326	64	95
61SC5258	0.00258	0.00846	0.215	5.5	848	259	83	124
61SC5162	0.00162	0.00531	0.268	6.8	546	166	129	192
61SC5102	0.00102	0.00335	0.253	6.4	622	190	124	185
61SC6640	0.00064	0.00210	0.319	8.1	391	119	197	294

Note: All Alloy 825 cold leads are terminated with stainless steel gland and 12-inch tails unless otherwise specified. Other configurations available on request.

TABLE 6 SERIES 32 MI HEATING CABLE SPECIFICATIONS (300 V, DUAL CONDUCTOR)

Heating cable reference	Nominal cable resistance at 20°C		Approximate cable diameter		Maximum unjointed cable length		Nominal weight	
	Ω/ft	Ω/m	in	mm	ft	m	lb/1000 ft	kg/1000 m
32SF1180	18.0	59.0	0.174	4.4	1271	387	49	73
32SF1110	11.0	36.1	0.156	4.0	1584	483	40	60
32SF2900	9.00	29.5	0.160	4.1	1507	459	42	63
32SF2750	7.50	24.6	0.157	4	1565	477	41	61
32SA2600	6.00	19.7	0.160	4.1	1507	459	42	63
32SA2400	4.00	13.1	0.146	3.7	1816	554	36	54
32SA2318	3.18	10.4	0.174	4.4	1277	389	50	74
32SA2275	2.75	9.02	0.153	3.9	1657	505	40	60
32SA2200	2.00	6.56	0.169	4.3	1359	414	49	73
32SA2170	1.70	5.58	0.167	4.2	1395	425	48	72
32SB2114	1.14	3.74	0.174	4.4	1279	390	51	76
32SB3914	0.914	3.00	0.162	4.1	1480	451	45	67

Heating cable reference	Nominal cable resistance at 20°C		Approximate cable diameter		Maximum unjointed cable length		Nominal weight	
	Ω/ft	Ω/m	in	mm	ft	m	lb/1000 ft	kg/1000 m
32SB3700	0.700	2.30	0.170	4.3	1347	411	50	74
32SQ3472	0.472	1.55	0.177	4.5	1232	376	52	78
32SQ3374	0.374	1.23	0.183	4.6	1153	352	55	82
32SQ3293	0.293	0.961	0.179	4.5	1206	368	53	79
32SQ3200	0.200	0.656	0.161	4.1	1498	457	44	66
32SQ3150	0.150	0.492	0.168	4.3	1378	420	49	73
32SQ3100	0.100	0.328	0.185	4.7	1140	348	60	89
32SP4734	0.0734	0.241	0.174	4.4	1284	391	52	78
32SP4583	0.0583	0.191	0.178	4.5	1230	375	55	82
32SP4458	0.0458	0.150	0.188	4.8	1105	337	62	92
32SC4324	0.0324	0.106	0.184	4.7	1145	349	57	85

TABLE 7 SERIES 62 MI HEATING CABLE SPECIFICATIONS (600 V, DUAL CONDUCTOR)

Heating cable reference	Nominal cable resistance at 20°C		Approximate cable diameter		Maximum unjointed cable length		Nominal weight	
	Ω/ft	Ω/m	in	mm	ft	m	lb/1000 ft	kg/1000 m
62SF1110	11.0	36.1	0.194	4.9	1023	312	61	91
62SF2900	9.00	29.5	0.194	4.9	1024	312	61	91
62SF2750	7.50	24.6	0.205	5.2	916	279	69	103
62SF2600	6.00	19.7	0.230	5.8	728	222	86	128
62SA2414	4.14	13.6	0.240	6.1	669	204	94	140
62SA2275	2.75	9.02	0.225	5.7	762	232	84	125
62SF2200	2.00	6.56	0.245	6.2	644	196	100	149
62SA2170	1.70	5.58	0.240	6.1	671	205	96	143
62ST2115	1.15	3.77	0.215	5.5	834	254	76	113
62SB3914	0.914	3.00	0.232	5.9	718	219	89	132
62SB3700	0.700	2.30	0.265	6.7	550	168	117	174
62ST3505	0.505	1.66	0.215	5.5	837	255	77	115
62SQ3374	0.374	1.23	0.215	5.5	834	254	76	113
62SQ3286	0.286	0.938	0.222	5.6	783	239	81	121
62SQ3200	0.200	0.656	0.227	5.8	750	229	86	128
62SQ3150	0.150	0.492	0.227	5.8	751	229	86	128
62SQ3100	0.100	0.328	0.257	6.5	586	179	111	165
62SP4775	0.0775	0.254	0.250	6.4	618	188	104	155
62SP4561	0.0561	0.184	0.263	6.7	560	171	116	173
62SP4402	0.0402	0.132	0.277	7	505	154	130	194
62SP4281	0.0281	0.0922	0.292	7.4	456	139	147	219
62SC4200	0.0200	0.0656	0.285	7.2	476	145	135	201
62SC4130	0.0130	0.0427	0.304	7.7	419	128	156	233
62SC5818	0.00818	0.0268	0.331	8.4	330	100	187	279
62SC5516	0.00516	0.0169	0.364	9.2	294	90	230	343
62SC5324	0.00324	0.0106	0.402	10.2	242	74	290	432
62SC5204	0.00204	0.00669	0.496	12.6	159	48	438	653
62SC5128	0.00128	0.00420	0.543	13.8	469	143	516	769

Thermal Design
1. Gather information
2. Calculate temperature differential
3. Calculate heat loss
4. Compensate for insulation type

The cold lead cable is available in the following sizes:

TABLE 8 ALLOY 825 SHEATHED COLD LEADS

Cold lead code for catalog number	Maximum voltage (V)	Maximum current (A)	Cold lead diameter		Gland size (NPT)	Gland size reference for catalog no.	Tail size (AWG)
			in	mm			
Design A, D, E							
S25A	600	25	0.355	9	1/2 in	N12	14
LS23A	300	23	0.319	8.1	1/2 in	N12	14
S34A	600	34	0.402	10.2	3/4 in	N34	10
S49A	600	49	0.496	12.6	3/4 in	N34	8
S65A	600	65	0.543	13.8	3/4 in	N34	6
Design B							
S29A	600	29	0.215	5.5	1/2 in	N12	12
S48A	600	48	0.253	6.4	1/2 in	N12	8
S66A	600	66	0.319	8.1	1/2 in	N12	6
S100A	600	100	0.402	10.2	3/4 in	N34	4
Note: MI cold lead minimum bending radius is 6 times the cable diameter.							

ADDITIONAL CONSIDERATIONS

Various materials used in the conductors behave differently. In particular, for heating cables with low resistances, conductor materials may show a significant increase in resistance for increasing maintain temperatures. Use the graph below to adjust resistance as a function of the maintain temperature. For detailed design, use TraceCalc Pro design software or contact nVent.

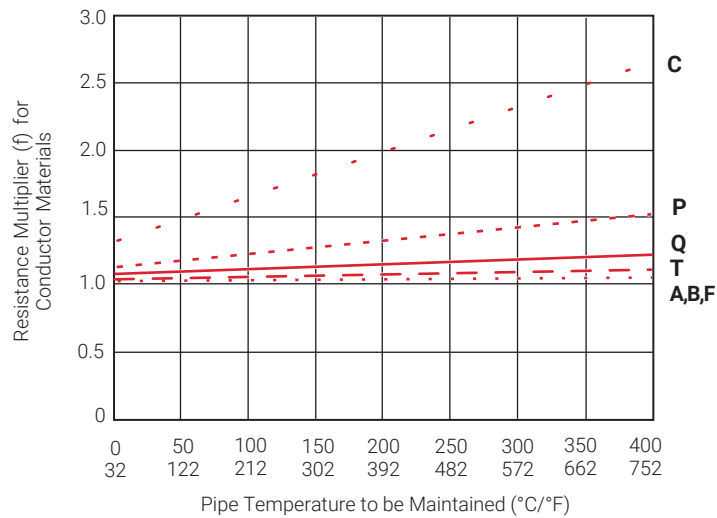

Fig. 6 Resistance correction factor

As the graph shows, the change of resistance can be significant at high temperatures and must not be neglected for cables using conductor materials with a large temperature dependency (see in particular conductor material C).

Adjust the nominal resistance (R_{nom}) with the resistance multiplier (f) based on the graph.

$$R_{adj} = R_{nom} \times f$$

Example:

Cable reference 32SB3700 uses conductor material B

The graph shows that the resistance change factor is negligible for this cable at a maintain temperature of 40°F (5°C). Therefore, $R_{adj} = 0.700 \text{ } \Omega/\text{ft} \times 1.0 = 0.700 \text{ } \Omega/\text{ft}$ (2.30 Ω/m).

Now calculate the adjusted power output (P_{adj}) of the heating cable using the following formula:

$$P_{adj} = V^2 / (R_{adj} \times L), P_{lin} = P/L$$

Example:

$$P_{adj} = (120 \text{ V})^2 / (0.7 \text{ } \Omega/\text{ft} \times 84 \text{ ft}) = 245 \text{ W}, P_{lin} = 2.9 \text{ W/ft} (9.5 \text{ W/m})$$

Check that the installed linear power, P_{lin} (W/ft or W/m), is equal to or greater than the pipe heat loss (P) determined in Step 2. Adjust formula for multiple runs as required.

Note: If the selected resistance is much lower than the calculated maximum resistance, it can result in a significantly higher power output than required for the application.

The startup current (I) can be calculated using the nominal resistance (R_{nom}) from Table 5–Table 7:

$$I = V / (R_{nom} \times L)$$

We typically recommend using a safety factor of 10%.

Example:

$$I = 120 \text{ V} / (0.700 \text{ } \Omega/\text{ft} \times 84) = 2 \text{ A (add 10\% } \geq 2.2 \text{ A)}$$

Canadian and U.S. National Electrical Codes require that circuit breakers must not be loaded above 80% of their nominal rating.

Be sure to also consider the maximum sheath temperature when using MI heating cables. The maximum sheath temperature depends on the power output of the cable, as well as the pipe temperature. It must not exceed the maximum rated temperature of the MI heating cable or the hot-to-cold joint, and must not be in conflict with hazardous area requirements. Sheath temperature calculations can be complex. Use TraceCalc Pro design software or contact your nVent representative for assistance.

Consider the option to select XMI-L heating cables where construction issues are introduced due to the need for multiple passes being balanced with AIT constraints.

Heating Cable Set Catalog Number

To order an MI heating cable set, it is important to understand the format of our catalog number:

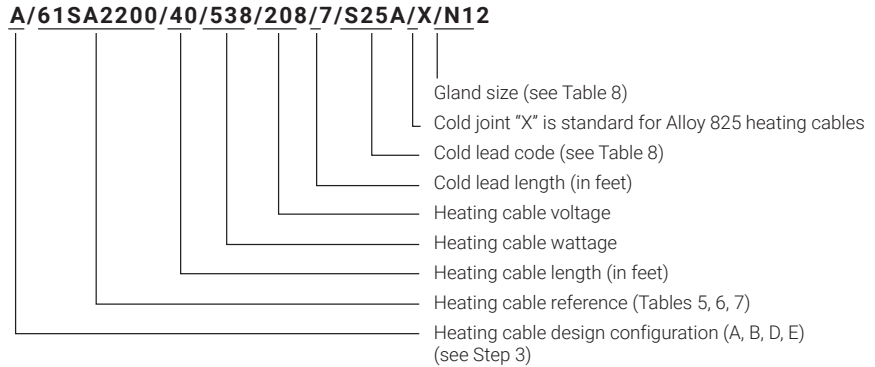

Fig. 7 MI heating cable set catalog number

In the previous heating cable catalog number, the length of the heated section and the cold lead is in feet. For metric lengths, the heating cable catalog number would include a suffix "M" after the length, as follows:

A/61SA2200/12.2M/538/208/2.1M/S25A/X/N12

Conversion from English to Metric units is: $L(\text{ft}) \times 0.3048 = L(\text{m})$

Conversion from Metric to English units is: $L(\text{m}) \times 3.2808 = L(\text{ft})$

Options

Add suffix "/PE" at the end of the catalog number for pulling eye (Design D cables only).

Add suffix "/RG1" at the end of the catalog number for 1" reverse gland (used to make a watertight seal) for Designs A and D cables. Design D cables also available with 1/2" or 3/4" reverse gland ("/RG34" for 3/4" or "/RG12" for 1/2").

Example:

The catalog number for our simple example would be:

MI heating cable set: D/32SB3700/84/245/120/7/S25A/X/N12

More examples:

D/62SQ3100/200/9920/480/4/S25A/X/N12 E/32SQ3200/25.0M/870/120/2.1M/LS23A/X/N12

- Heating cable configuration is Design D
- 600-V rated dual conductor cable, resistance at 20°C is 0.100 Ω/ft (0.328 Ω/m)
- Heating cable length is 200 ft (61 m)
- Heating cable wattage is 9920 W at 480 V
- Cold lead length is 4 ft (1.2 m)
- Cold lead code is S25A
- 1/2-in NPT gland connector
- Heating cable configuration is Design E
- 300-V rated dual conductor cable, resistance at 20°C is 0.200 Ω/ft (0.656 Ω/m)
- Heating cable length is 25 m (82 ft)
- Heating cable wattage is 870 W at 120 V
- Cold lead length is 2.1 m (7 ft)
- Cold lead code is LS23A
- 1/2-in NPT gland connector

Note: Note: See H59079 for XMI-L nomenclature and catalog number example.

nVent will need the following information to prepare the reference tag supplied with each MI heating cable set:

- Supply voltage and wattage
- Circuit ID (optional, for customer reference only)
- TraceCalc Pro "Series Cable Tag List" report (if heating cable is designed using TraceCalc Pro)

For hazardous locations, also include:

- Area classification (Class, Division, Group)
- Temperature identification number (T-rating) or autoignition temperature (AIT) of flammables handled in the hazardous area
- Appendix I must be completed and returned to nVent for Class I, Division 1 applications
- Maximum sheath temperature of heating cable

The maximum sheath temperature of the MI heating cable depends on the specific application. Contact your nVent representative to provide you with an optimized design for your application.

Selection of Connection Kits and Accessories

nVent RAYCHEM MI heating cables are approved as a complete system only when used with nVent connection kits or any Nationally Recognized Testing Lab (NRTL) enclosure. Any non-approved connection kits may compromise the reliability of the system and will invalidate approvals and warranties.

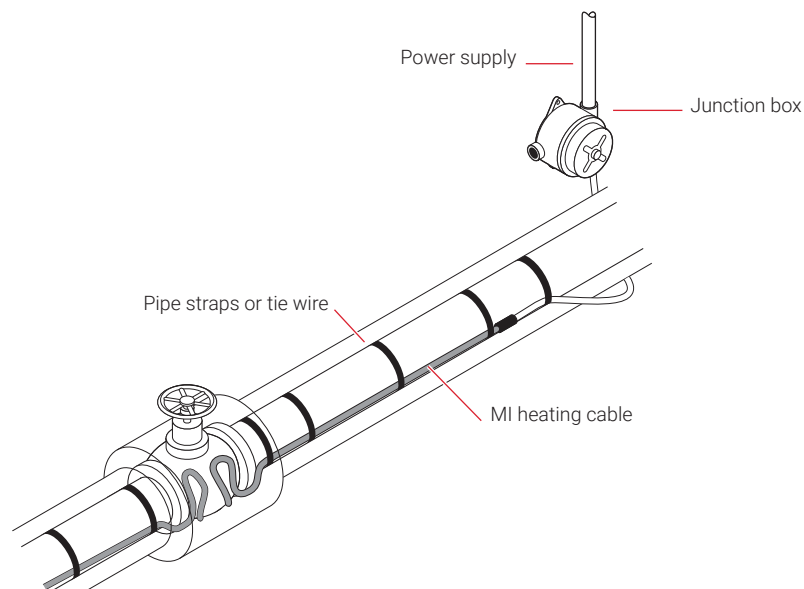
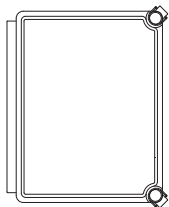

Fig. 8 Typical MI heating system

TABLE 9 CONNECTION KITS AND ACCESSORY SELECTION

Description	Catalog number	Quantity required
Components		
1 Power connection	MIJB or XMI-JB or RMI-JB3, 1-2 heating cables or PT-JB or JBS-100-ECP-A + MI-GROUND-KIT (nonhazardous locations only) or JBS-100-ECW-A + MI-GROUND-KIT (nonhazardous locations only)	1 per circuit 1 per circuit 1 per circuit 1 per circuit 1 per circuit 1 per circuit
Accessories		
2 Attachment material		
Pipe straps	PB... (see Table 3.10)	1 every foot
Tie wire	or 051Cupron	See Table 11
Prepunched strapping	107826-000	See Table 11
Banding (and clips)	BAND100FT BANDCLIP100	See Table 11
MIJB mounting bracket	MBRP-B	2 per MIJB
Pipe straps for MBRP-B	PS...	1 per MBRP-B
Electric traced labels	ETL	Every 10 feet
Consider mesh to hold heating cable against awkward shapes HWA-METAL-MESH-SS-50MM-10M		
Temperature controls – see Control and Monitoring design guide (H56889)		

System Components



POWER CONNECTION KITS

nVent RAYCHEM MIJB-864-A Junction box with pre-drilled earth plate for use with MI heating units.

Typical uses - Power, splice and end box for 3 phase systems

Hazardous locations: CID2 Groups B, C and D. Maximum operating voltage 600Vac. Maximum 35A per terminal, rated 18AWG to 6AWG, NEMA 4X.

Entries: Up to 8 x 1/2" and 3 x 3/4". Power cable gland and hubs not included. Two mounting brackets (MBRP-B) and two pipe straps must be ordered separately for installation.

Enclosure dimensions: 8" x 6" x 4" (200 x 150 x 100 mm)

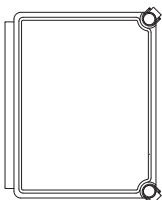

nVent RAYCHEM MIJB-1086-A Junction box with pre-drilled earth plate for use with MI heating units. Accommodates up to 3 power cables.

Typical uses - Power, splice and end box for 3 phase systems

Hazardous locations - CID2 Groups B, C and D. Maximum operating voltage 600Vac. Maximum 35A per terminal, rated 18AWG to 6AWG, NEMA 4X.

Entries: Up to 11 x 1/2" and 8 x 3/4". Power cable gland and hubs not included. Two mounting brackets (MBRP-B) and two pipe straps must be ordered separately for installation. Order a separate MIJB-LPWR-KIT for #2 or #4AWG power cable to downsize to #6AWG (35A).

Enclosure dimensions: 10" x 8" x 6" (250 x 200 x 150 mm)

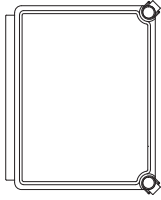

nVent RAYCHEM MIJB-1086-B Junction box with pre-drilled earth plate for use with MI heating units. Accommodates up to 7 outgoing heating cables and one incoming power cable. It can also be used as a marshalling box – one incoming power cable and 5 outgoing power cables.

Typical uses - Power or marshalling, splice and end box for 3 phase systems.
Hazardous locations: CID2 Groups B, C and D. Maximum operating voltage 600Vac.
Maximum 35A per terminal, rated 18AWG to 6AWG, NEMA 4X.

Entries: Up to 11 x 1/2" and 8 x 3/4". Power cable gland and hubs not included. Two mounting brackets (MBRP-B) and two pipe straps must be ordered separately for installation. Order a separate MIJB-LPWR-KIT for #2 or #4AWG power cable to downsize to #6AWG (35A).

Enclosure dimensions: 10" x 8" x 6" (250 x 200 x 150 mm)

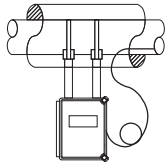

nVent RAYCHEM MBRP-B Enclosure mounting bracket for MIJB series fiberglass enclosures. Mounting bracket enables enclosure installation and connection prior to application of insulation and cladding. Stainless steel pipe support bracket for MIJB-864-A, MIJB-1086-A and MIJB-1086-B fiberglass enclosures. Two brackets are required to support each enclosure. Each bracket requires one pipe strap.

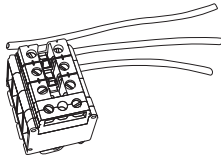

nVent RAYCHEM MIJB-LPWR-KIT Terminal kit to facilitate downsizing of large power cables.

Large power wire kit to downsize #2 or #4 power cable to #6AWG (max 35amps for enclosure terminal blocks). Use with MIJB-1086-A and MIJB-1086-B enclosures as required.

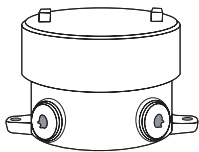

nVent RAYCHEM XMI-JB Aluminum enclosure for CID1 areas.

Typical uses: MI heating units power or splice connection box, RTD connection box

Hazardous locations - CID1 Groups B, C and D, Maximum operating voltage 600Vac, Includes 4 pole terminal block (CSA-600 Vac, 65 A, 18-6 AWG /UL-300 Vac, 65 A, 18-6 AWG), NEMA 4X.

Entries : 5 x 3/4" and includes 3 x 3/4" plugs, two reducer bushings (3/4" x 1/2") and two mounting feet with space to tap hole for bonding wire. Power cable gland should be purchased separately. Additional terminal strips or reducer bushings may also be purchased separately for additional RTD connection.
(4POLETSTRIP and PTRDBH3412)

Enclosure dimensions: 4 1/2" x 3 1/2" (114 x 89 mm).

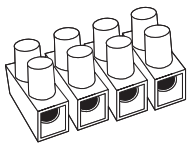

nVent RAYCHEM 4POLETSTRIP Terminal strip for enclosure,

4 pole terminal strip (CSA-600 Vac, 65 A, 18-6 AWG /UL-300 Vac, 65 A, 18-6 AWG) for use with XMI-JB enclosure. May be used for additional RTD connections.

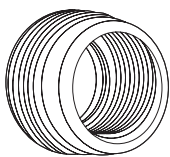

nVent RAYCHEM PTRDBH3412 Reducer bushing for enclosure,

Zinc plated steel reducer bushing for use with XMI-JB enclosure. Reduces 3/4" NPT tapered hole to 1/2" NPT. Body length 23/32" (18mm), Class I, Div. 1 & 2, Groups A, B, C, D. Class I, Zone 1, Groups IIC, IIB, IIA. Class II, Div. 1 & 2, Groups E, F, G.

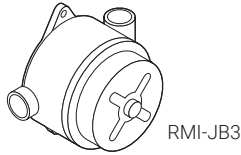

RMI-JB3

nVent RAYCHEM RMI-JB3 Copper-free aluminum alloy box with three entries for use with MI heating cables.

Typical use : power or splice connection box

Includes terminal block (500 Vac, 50 A, 2 x 6 AWG) and three 3/4" x 1/2" reducers and two 3/4" NPT plugs. FM and CSA approved for: Class I, Div. 1 & 2, Groups B, C, D; Class II, Div. 1 & 2, Groups E, F, G; and Class III.

Enclosure dimensions: 6.1" x 5.2" x 3.9" (156 mm x 133 mm x 98 mm).

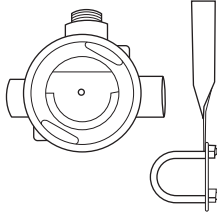

PT-JB

nVent RAYCHEM PT-JB A smaller ferro-alloy junction box with three entries for use with MI heating cables.

Typical use : power or splice connection box

Three 3/4" NPT entries. Provided with one plug and two 3/4" x 1/2" reducers. Includes 4 pole terminal block (CSA-600 Vac, 65 A, 18-6 AWG / UL-300 Vac, 65 A, 18-6 AWG) and stainless steel support bracket (U-clamp). UL and CSA approved for: Class I, Div. 1 & 2, Groups A, B, C, D; Class II, Div. 1 & 2, Groups E, F, G.

Enclosure dimensions: 5.5" x 4.75" x 3" (140 mm x 121 mm x 76 mm).

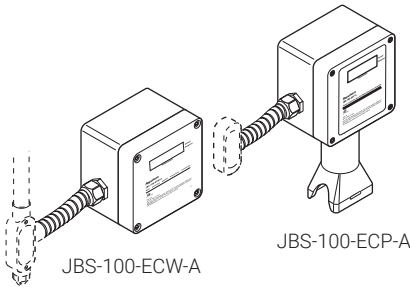

JBS-100-ECW-A

JBS-100-ECP-A

nVent RAYCHEM JBS-100-ECP-A and JBS-100-ECW-A Electronic temperature controllers that provide accurate control of a heating circuit using a RTD sensor.

Adjustable set points between 32°F to 425°F (0°C to 218°C), power input of 120 Vac to 277 Vac, and current switching up to 30 A. c-CSA-us (certified to U.S. and Canadian Standards) for use in nonhazardous locations. Requires MI grounding kit.

The JBS-100-ECP-A is pipe mounted and serves as a power connection kit for both nVent RAYCHEM self-regulating and nVent RAYCHEM mineral insulated heating cables.

The JBS-100-ECW-A is wall mounted and similarly serves as a power connection kit for both nVent RAYCHEM self-regulating and nVent RAYCHEM mineral insulated heating cables.

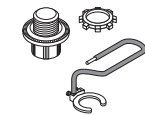

MI-GROUND-KIT

nVent RAYCHEM MI-GROUND-KIT Required grounding kit for use with JBS-100-ECP-A and JBS-100-ECW-A. Allows for a direct connection to a nVent RAYCHEM MI heating cable, eliminating the need for a separate junction box.

Accessories



PB

ATTACHMENT MATERIALS

nVent RAYCHEM PB Stainless-steel straps for holding MI heating cables onto pipe. Pliers are the only tool required to pull the pipe strap tight. Allow one pipe strap per foot of pipe (3.3 pipe straps per meter of pipe).

TABLE 10 AVAILABLE PIPE STRAPS

Order Reference	Pipe diameter	Package quantity
PB 125	To 1-1/4"	50 pc
PB 300	1-1/2" to 3"	35 pc
PB 600	3-1/2" to 6"	25 pc
PB 1000	6" to 10"	1 pc
PB 1200	To 12"	1 pc
PB 2400	To 24"	1 pc
PB 3600	To 36"	1 pc

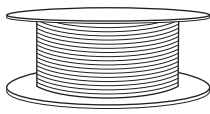

051CUPRON



nVent RAYCHEM 051Cupron 16 AWG tie wire for fastening Alloy 825 MI heating cables on pipes. Do not use with copper-sheathed MI heating cables; use PB pipe straps. Particularly good for irregular shaped objects like valves and pumps. Order quantity as required (in ft) as per Table Table 8.

RMI-TW 559600-000 Tie wire for fastening steel heating cables on pipes. Especially suitable for irregular shaped objects such as pumps, valves, flanges. Supplied in 50m reels.

TABLE 11 ALLOWANCE FOR TIE WIRE AND PREPUNCHED BANDING ON PIPES

Pipe size (inches)	1	1.5	2	4	6	8	10	12	14	16	18	20	24	30	36	48
Required length (ft) per ft of pipe	0.8	1.1	1.2	1.6	2.1	2.8	3.5	4.2	4.6	5.2	5.9	6.5	7.9	9.8	11.8	15.7
Required length (m) per m of pipe	0.8	1.1	1.2	1.6	2.1	2.8	3.5	4.2	4.6	5.2	5.9	6.5	7.9	9.8	11.8	15.7

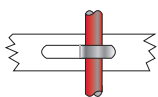

nVent RAYCHEM HARD-SPACER-SS-25MM-25M Stainless steel prepunched strapping to hold MI heating cable in place. Supplied in 82 ft (25.0 m) rolls.

Use on large pipes to simplify installation of multiple heating cables. For quantities, see Table 11 (installation every 1 ft = 0.328 m).

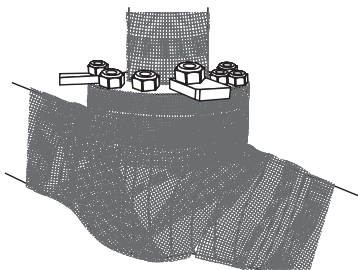

nVent RAYCHEM HWA-METAL-MESH-SS-50MM-10M Stainless steel mesh for fixation of heating cables on valves, pumps or other odd shaped surfaces. This mesh provides optimum contact and heat transfer between heating cables and heated equipment and can be used for exposure temperatures up to 400°C

10 m per roll. 50 mm width. Weight: 0.36 kg.



nVent RAYCHEM BAND100FT

Stainless steel banding used to strap MI cables to pipes
Ideal for large OD pipes
100ft roll x ½" wide x 0.020" thick
(30m x 12.5mm wide x 0.5mm thick)
Use with BANDCLIP100 banding clips ordered separately



nVent RAYCHEM BANDCLIP100

Stainless steel clips used with stainless steel banding
100 clips per package
Use with BAND100FT ordered separately

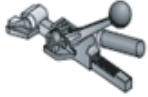

nVent RAYCHEM T34P

Ratchet-type tensoning tool tightens stainless-steel banding used to support MI Cables.

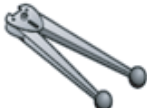

nVent RAYCHEM S12P

Crimping tool used to crimp clip onto stainless-steel banding.

Electric Traced Label



ETL

nVent RAYCHEM ETL - English

ETL - French Attach the label to the outside of the thermal insulation weather barrier to indicate presence of electrical heat tracing. Use one label for every 10 feet (3 m) of pipe, alternating on either side of the pipe. Also install at equipment requiring periodic maintenance (control valves, pumps, instruments, etc.).

Temperature Controls

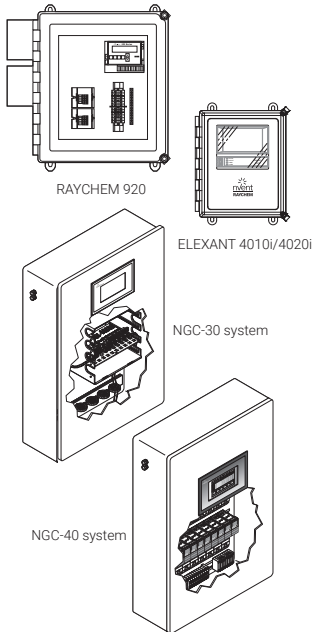

For a complete selection of control and monitoring products, including line-sensing thermostats, see Control and Monitoring design guide (H56889).

North America

Tel +1.800.545.6258
Fax +1.800.527.5703
info@nVent.com

Latin America

Tel +1.713.868.4800
Fax +1.713.868.2333
info@nVent.com



Our powerful portfolio of brands:

CADDY ERICO HOFFMAN RAYCHEM SCHROFF TRACER