

Mineral insulated (MI) Inconel sheathed heating cable

PRODUCT OVERVIEW

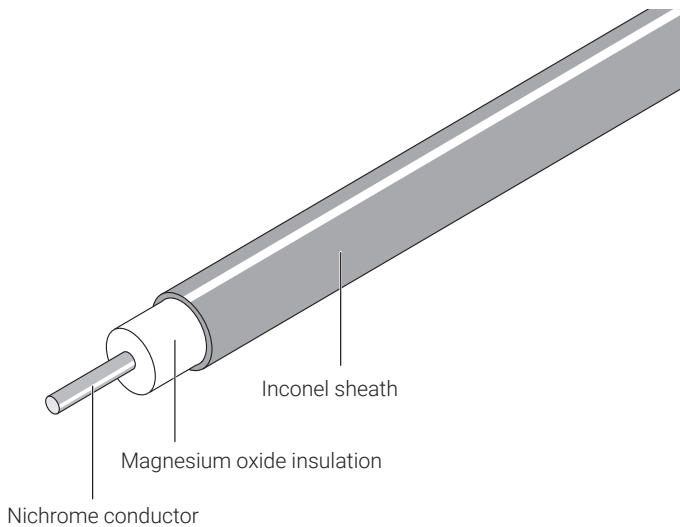

nVent RAYCHEM HIQ mineral insulated (MI) Inconel 600 series heating cables are suited for use in hazardous areas. The Inconel 600 sheath offers excellent corrosive properties against a wide range of organic acids and alkalis, as well as chloride stress-corrosion cracking, in combination with a high temperature withstand capability. HIQ cables are typically used in bitumen plants, gas plants, oil refineries, reactors and vessels, sodium loops and a wide variety of other heat-tracing applications where temperature resistance, power output and durability are required and exceed the limitations of stainless steel sheathed MI heating cables. The heating cables can be used for exposure temperatures up to 680°C and a typical power output up to 300 W/m. Higher temperatures and power outputs can be achieved, contact nVent for assistance. The heating cables are offered as bulk cables as well as factory-terminated heating units employing brazing or laser welding techniques to ensure optimum quality of the connections. The offering is completed with a full range of components for installation, connection and splicing of the heating cables.

PRODUCT SPECIFICATIONS

Technical details

Cable sheath material	Inconel 600	
Conductor material	Nichrome	
Max. exposure temperature	550°C (brazed heating units) 680°C* (laser welded heating units) *Higher temperatures can be realized, contact nVent	
Min. installation temperature	-60°C	
Min. bending radius	6 x outer diameter at -60°C	
Max. supply voltage and power	Voltage (U0/U) 300/500 Vac 460/600 Vac (laser welded heating units)	Max. power output* 300 W/m *typical value, depending on application
Earth leakage	3 mA/100 m (nominal at 20°C)	
Min. cable spacing	25 mm for hazardous areas	

MI series heating cables HIQ

Order Reference	Nominal Resistance (Ω/Km @ 20°C)	Outer Diameter (mm)	Temp. Coefficient (x 10 ⁻³ /K)	Max. Coil Length [m]	Nom. Weight (kg/km)
HIQ1M10K	10000	3.2	0.09	772	39
HIQ1M6300	6300	3.2	0.09	774	39
HIQ1M4000	4000	3.2	0.09	776	39
HIQ1M2500	2500	3.4	0.09	689	46
HIQ1M1600	1600	3.6	0.09	617	52
HIQ1M1000	1000	3.9	0.09	528	62
HIQ1M630	630	4.3	0.09	437	78
HIQ1M400	400	4.7	0.09	368	96
HIQ1M250	250	5.3	0.09	292	127
HIQ1M160	160	6.5	0.09	194	191

Recommended cold leads for HIQ MI series heating cables

Cold Lead Code	Sheath Material	Current Rating (A)	Voltage Rating (Vac)	No of Conductors	Design*	Cable O.D. (mm)	Pigtail Size (mm ²)	Gland Size
S33A	Alloy 825	33	600	1	B	5.5	3.3	M25
S55A	Alloy 825	55	600	1	B	6.4	8.4	M25

* For details on the different heating unit designs, refer to chapter MI heating Systems - MI heating Cables in the Databook (reference DOC2210)

Nickel plated brass glands are standard on all heating units. Other materials are possible, contact nVent for more information.

Delivery length of bulk cable on coil depends on type of resistance and is limited by max. coil length as indicated in the table on top. Factory terminated elements are limited by a max. weight of 50 kg, however to ensure practical and safe on-site handling, it is strongly recommended to limit element lengths to 25 - 30 kg. Not all resistances are standard items and as such may not be in stock. Contact nVent to confirm lead time. nVent requires the use of a 30 mA residual current device to provide maximum safety and protection from fire.

Where design results in higher leakage current, the preferred trip level for adjustable devices is 30 mA above any inherent capacitive leakage characteristic of the heater as specified by the trace heater supplier or alternatively, the next common available trip level for non adjustable devices, with a maximum of 300 mA. All safety aspects need to be proven.

Also refer to the components section for more details on heating units, accessories and nomenclatures.

MI heating cable sheath corrosion resistance and temperature data

Sheath Material	Description	Sulphuric Acid	Hydrochloric Acid	Hydrofluoric Acid	Phosphoric Acid	Nitric Acid	Organic Acid	Alkalis	Sea Water	Chloride
Inconel 600 DIN 2.4816	High nickel, high chromium content inconel alloy 600	X	X	A	X	X	GE	GE	A	GE

Note: NR - Not recommended, A - Acceptable, GE - Good to excellent, X - Check for specific data

Temperature limitation based on construction of heating element.

Corrosion resistance data is dependent on temperature and concentration.

APPROVALS

For use in ordinary and hazardous area Zone 1 and Zone 2 (Gas), Zone 21 and Zone 22 (Dust)

Temperature classification

T6 ... T1

nVent RAYCHEM heat-tracing products are approved for the listed temperature classifications by using the principles of stabilized design. Use TraceCalc design software or contact nVent.

Product certification



More details about product certification, approvals and conditions of safe use are available in the Mineral Insulated (MI) series heating systems installation manual at www.nVent.com/RAYCHEM.

ORDERING INFORMATION

- Due to the sensitivity & craftsmanship required to assemble an MI heating unit, they are usually purchased as factory terminated units. Refer to the "MI Heating Systems Nomenclature" datasheet for more information on the ordering references for complete units or contact your local nVent representative.
It is strongly recommended to use nVent design software such as TraceCalc Pro to validate the design and ordering string.
- To purchase MI heating cables in bulk, refer to the tables with the cable references on page 2 in this document.

North America

Tel +1.800.545.6258
Fax +1.800.527.5703
thermal.info@nVent.com

Europe, Middle East, Africa

Tel +32.16.213.502
Fax +32.16.213.604
thermal.info@nVent.com

Asia Pacific

Tel +86.21.2412.1688
Fax +86.21.5426.3167
cn.thermal.info@nVent.com

Latin America

Tel +1.713.868.4800
Fax +1.713.868.2333
thermal.info@nVent.com



Our powerful portfolio of brands:

CADDY ERICO HOFFMAN RAYCHEM SCHROFF TRACER