

RAYCHEM

RayClic Connection System

Installation Instructions

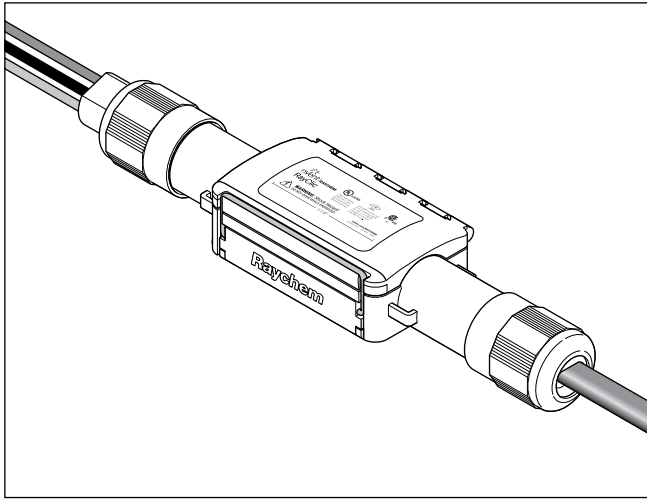

DESCRIPTION

nVent RAYCHEM RayClic-PC Power Connection and End Seal Kit
 nVent RAYCHEM RayClic-PS Powered Splice and End Seal Kit
 nVent RAYCHEM RayClic-PT Powered Tee and End Seal Kit

These kits are for use with nVent RAYCHEM IceStop, XL-Trace Edge and HWAT heating cables. The connection is designed to be strapped to the pipe or mounted on the wall at the start of the heating cable circuit. These installation instructions should be used in conjunction with the IceStop, XL-Trace Edge and HWAT System Installation and Operation Manuals. For technical support, contact your nVent representative or call nVent (800) 545-6258.

TOOLS REQUIRED

- Wire cutters
- TORX® T20 screw driver
- Utility knife
- Wrenches (2)

ADDITIONAL UL LISTED OR CSA CERTIFIED MATERIALS REQUIRED:

- 1/2 inch flame retardant conduit and fittings
- Junction box

OPTIONAL ACCESSORIES (NOT INCLUDED IN THIS KIT)

- RayClic-SB-02 Wall mounting bracket

APPROVALS

 **UL US LISTED** 718K Pipe Heating Cable

 **UL LISTED** 877Z De-Icing and Snow Melting
 Not UL Listed with XL-Trace Edge heating cable for buried piping



 **FM APPROVED**
 For IceStop (GM-XT) only
 Class I, Div. 2, Groups A, B, C, D

WARNING:

This component is an electrical device that must be installed correctly to ensure proper operation and to prevent shock or fire. Read these important warnings and carefully follow all the installation instructions.

- To minimize the danger of fire from sustained electrical arcing if the heating cable is damaged or improperly installed, and to comply with the requirements of nVent, agency certifications, and national electrical codes, ground fault equipment protection must be used. Arcing may not be stopped by conventional circuit breakers.
- Bus wires will short if they contact each other. Keep bus wires separated.
- Keep components and heating cable ends dry before and during installation.
- The black heating cable core is conductive and can short. It must be properly insulated and kept dry.
- Component approvals and performance are based on the use of nVent-specified parts only. Do not use substitute parts or vinyl electrical tape.
- Leave these instructions with end user for reference and future use.

KIT CONTENTS

RayClic-PC Power Connection Kit

Item	Qty	Description
A	1	Power connection
B	1	Pipe mounting bracket
C	2	Plastic cable ties
D	1	Clip
E	1	End seal
F	4	Labels (1 HWAT, 1 De-Icing & Snow Melting, 2 Warning)
G	1	Cable lubricant (for use with HWAT cables only)

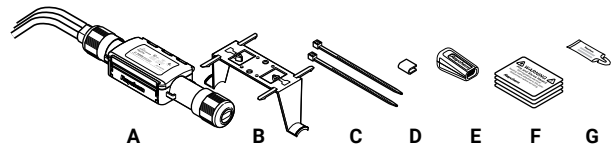

RayClic-PS Powered Splice Kit

Item	Qty	Description
A	1	Powered splice
B	1	Pipe mounting bracket
C	2	Plastic cable ties
D	2	Clips
E	2	End seals
F	4	Labels (1 HWAT, 1 De-Icing & Snow Melting, 2 Warning)
G	1	Cable lubricant (for use with HWAT cables only)

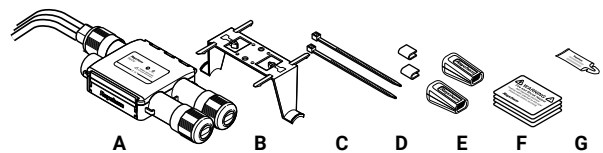

RayClic-PT Powered Tee Kit

Item	Qty	Description
A	1	Powered splice
B	1	Pipe mounting bracket
C	2	Plastic cable ties
D	3	Clips
E	3	End seals
F	4	Labels (1 HWAT, 1 De-Icing & Snow Melting, 2 Warning)
G	1	Cable lubricant (for use with HWAT cables only)

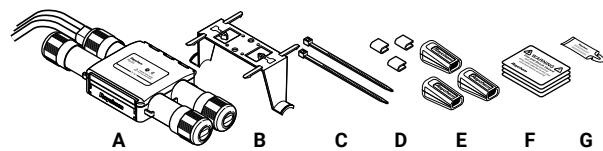

If you experience difficulty during installation, refer to the "Troubleshooting Guide" on page 10.

POWER CONNECTION, SPLICE AND TEE INSTALLATION

1

- Using the plastic cable ties, attach* the bracket to the pipe.

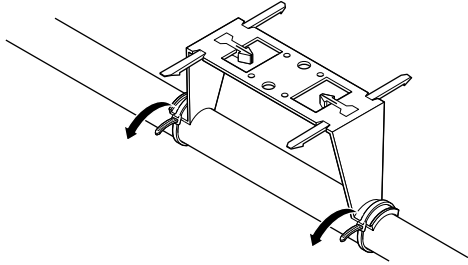

* For roof-mounted applications, follow steps 3 through 9 (pages 5–7), then turn to "Roof Installation" on page 8.

2A

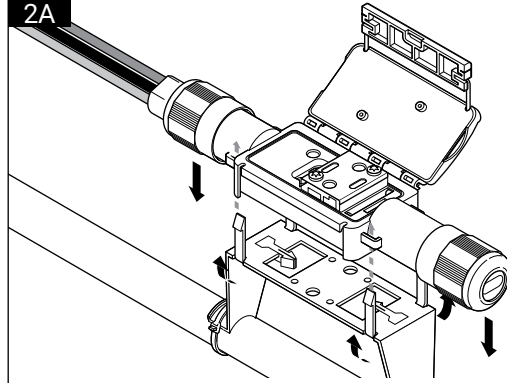

- For the RayClic-PC power connection, fold up the four outer snaps, then position the connector over the snaps and press down.

2B

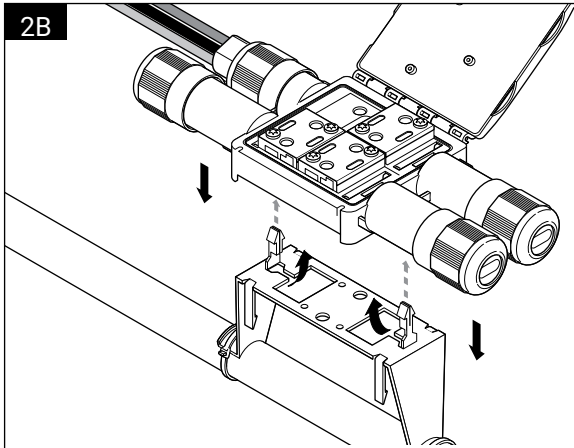

- For the RayClic-PS powered splice and the RayClic-PT powered tee, fold up two center snaps, then position the connector over the snaps and press down.

3

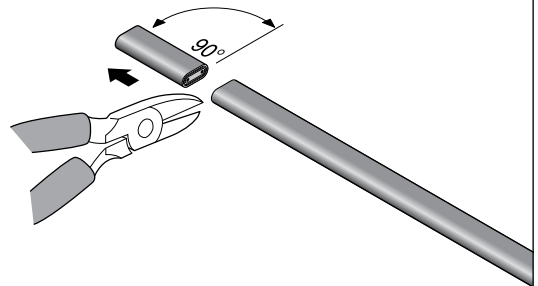

- Allow enough extra heating cable to make service loops as required.
- Make sure the end of the heating cable is cut clean.

4

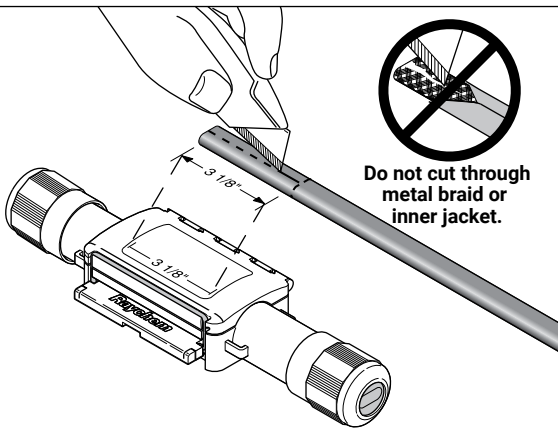

- Score around and down the outer jacket of the heating cable 3 1/8 inches from the end.

5

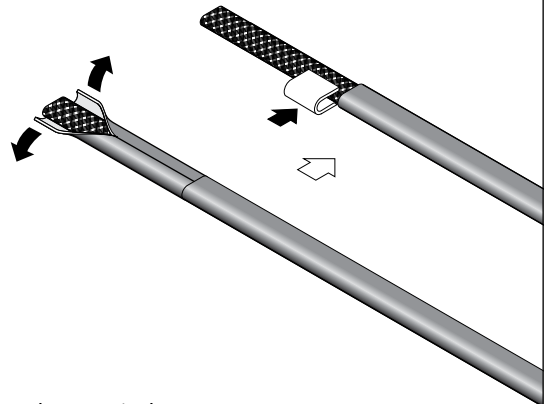

- Remove the outer jacket.
- Place the metal clip over the base of the exposed braid.

HWAT ONLY

6A

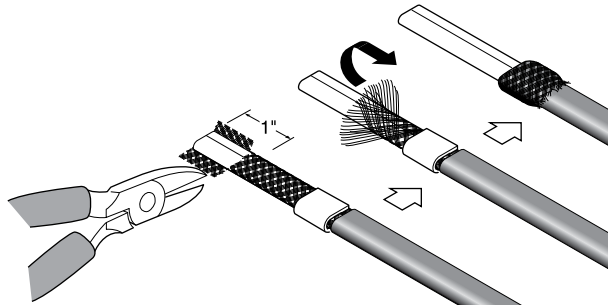

- Using wire cutters, cut away 1 inch of the braid.
- Pull exposed braid back over metal clip.

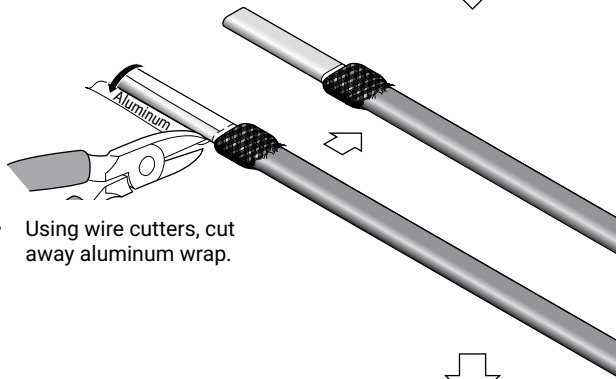

- Using wire cutters, cut away aluminum wrap.

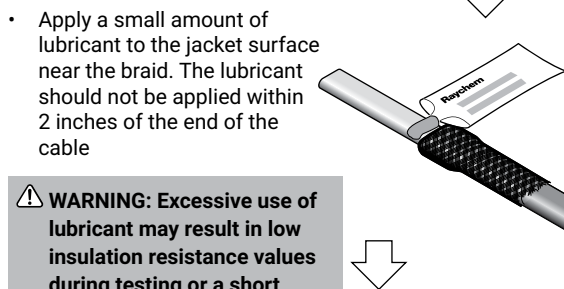

- Apply a small amount of lubricant to the jacket surface near the braid. The lubricant should not be applied within 2 inches of the end of the cable

⚠ WARNING: Excessive use of lubricant may result in low insulation resistance values during testing or a short circuit across the bus wires.

- Apply HWAT label on insulated hot water tank.

For HWAT Systems install this label on the hot water heater.

ATTENTION  150°F

DO NOT heat water above 150°F. Temperatures above 150°F will permanently reduce the power output of the HWAT heating cable on this hot water system.

ICESTOP AND XL-TRACE EDGE ONLY

6B

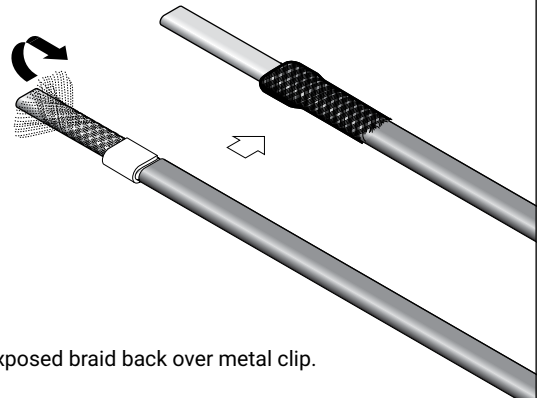

- Pull exposed braid back over metal clip.

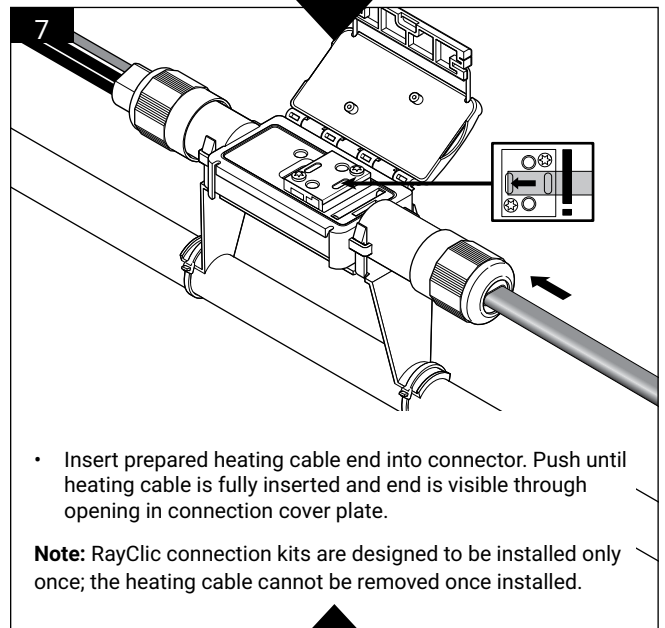

- Insert prepared heating cable end into connector. Push until heating cable is fully inserted and end is visible through opening in connection cover plate.

Note: RayClic connection kits are designed to be installed only once; the heating cable cannot be removed once installed.

8

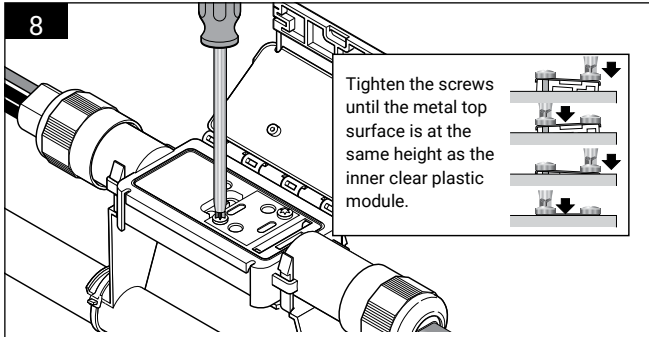

Tighten the screws until the metal top surface is at the same height as the inner clear plastic module.

- Securely tighten the two connection screws, alternating as they are being tightened.
- For Powered Splice and Tee kits, repeat steps 3 through 8 for all remaining heating cable entries.

⚠ WARNING: Fire hazard. Loose screws can cause excessive heating. Be sure screws are fully tightened.

9

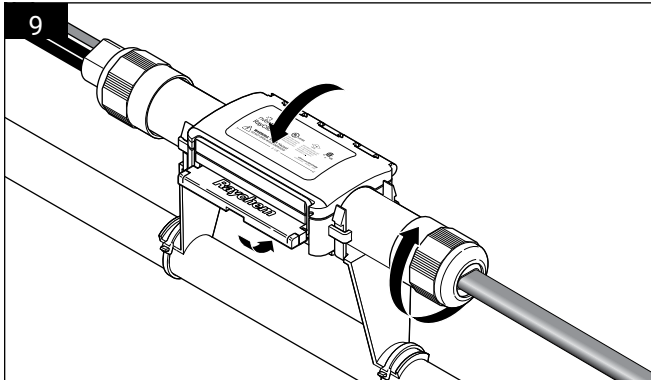

- Close the lid and snap the lever shut. Do not force lid closed; if lid does not close, check the connection to ensure all screws are fully tightened.
- Tighten the nuts on the heating cable entries until grommets are compressed.

10

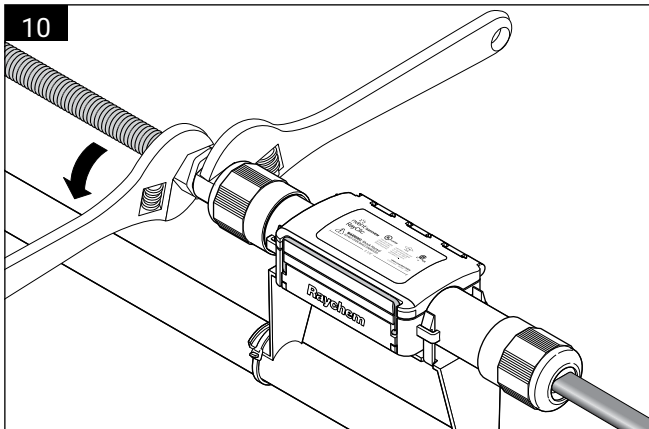

- Using two wrenches, attach user-supplied 1/2 inch conduit. To avoid breaking housing, do not exceed 15 ft-lbs of torque. Broken connectors must be replaced.

11A

Power Connection

- To prevent damage to heating cables, protect from sharp cladding edges.
- To prevent water ingress, seal the heating cable where it penetrates the insulation.

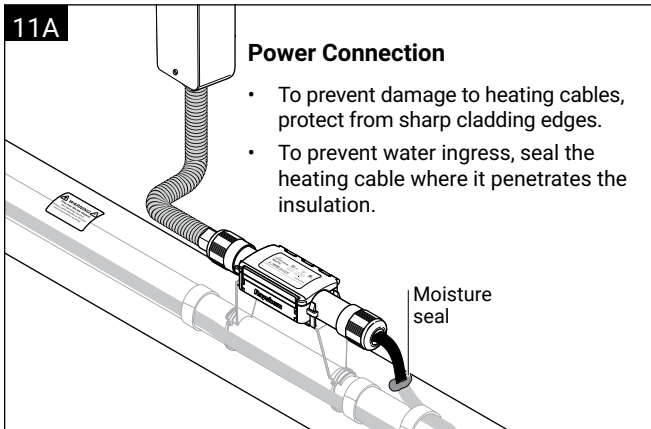

Moisture seal

- Using glass cloth tape, attach heating cable to pipe.
- Apply insulation, cladding and warning labels.
- Terminate power wiring in user-supplied junction box.

11B

Powered Splice

- To prevent damage to heating cables, protect from sharp cladding edges.
- To prevent water ingress, seal the heating cable where it penetrates the insulation.

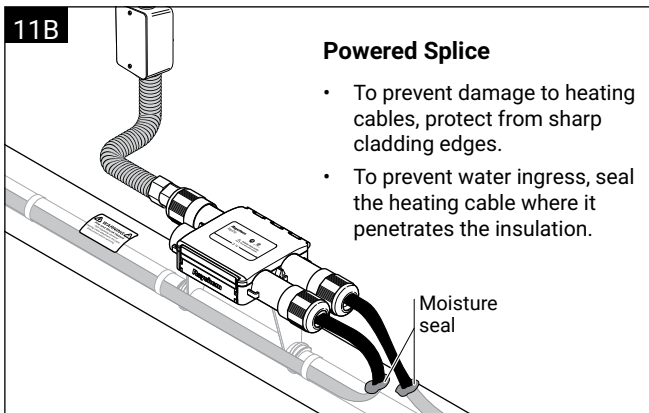

Moisture seal

- Using glass cloth tape, attach heating cable to pipe.
- Apply insulation, cladding and warning labels.
- Terminate power wiring in user-supplied junction box.

11C

Powered Tee

- To prevent damage to heating cables, protect from sharp cladding edges.
- To prevent water ingress, seal the heating cable where it penetrates the insulation.

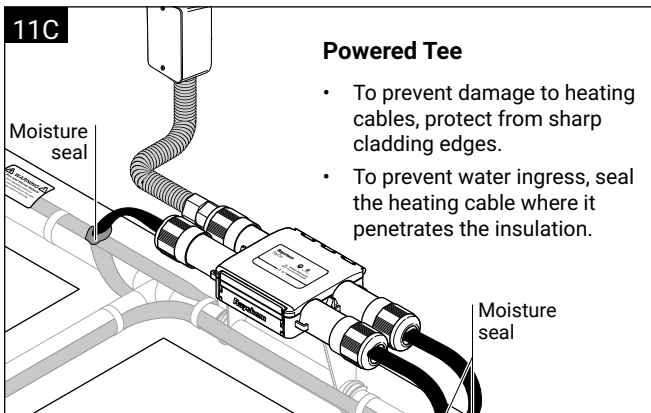

Moisture seal

Moisture seal

- Using glass cloth tape, attach heating cable to pipe.
- Apply insulation, cladding and warning labels.
- Terminate power wiring in user-supplied junction box.

ROOF INSTALLATION

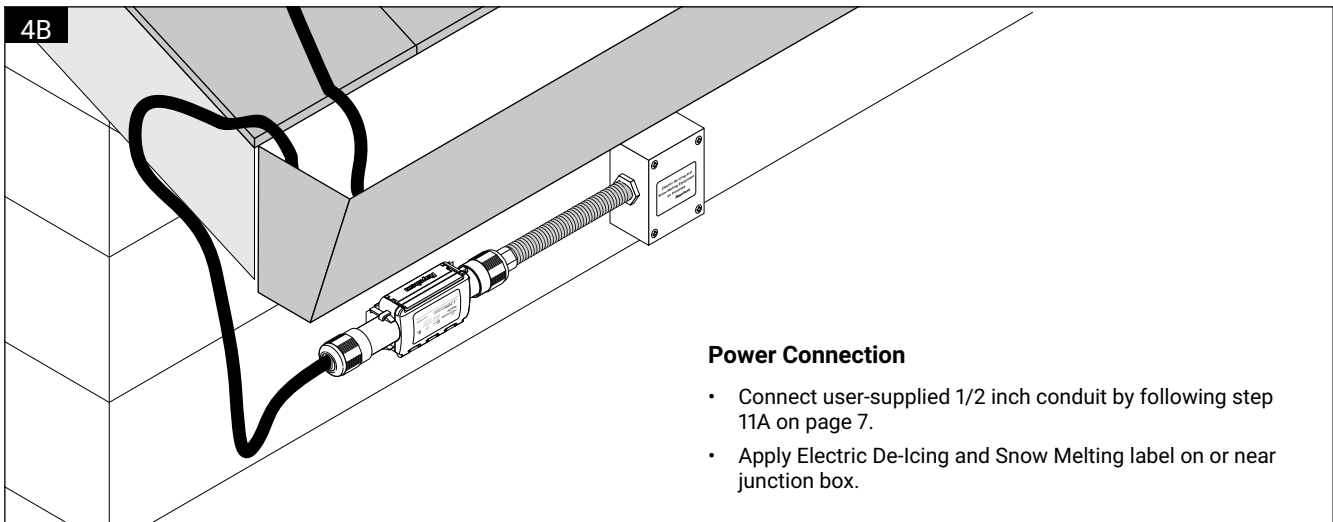
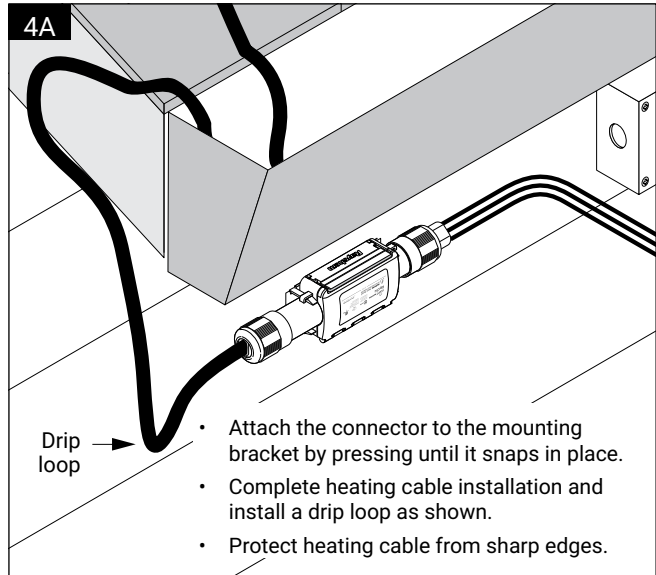
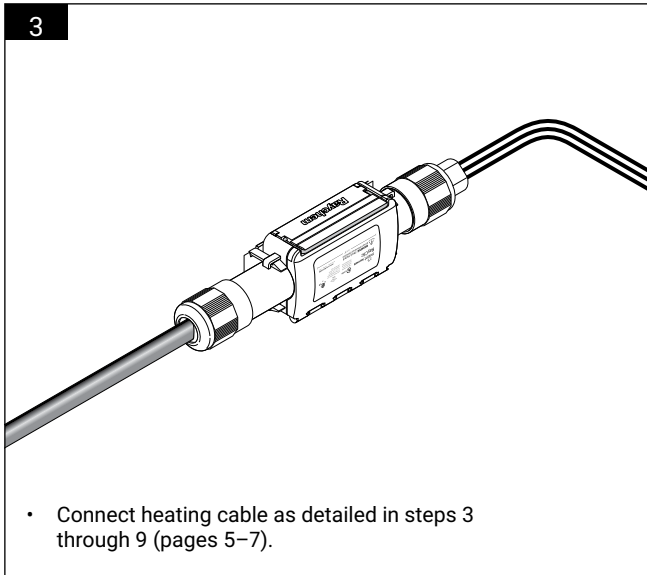
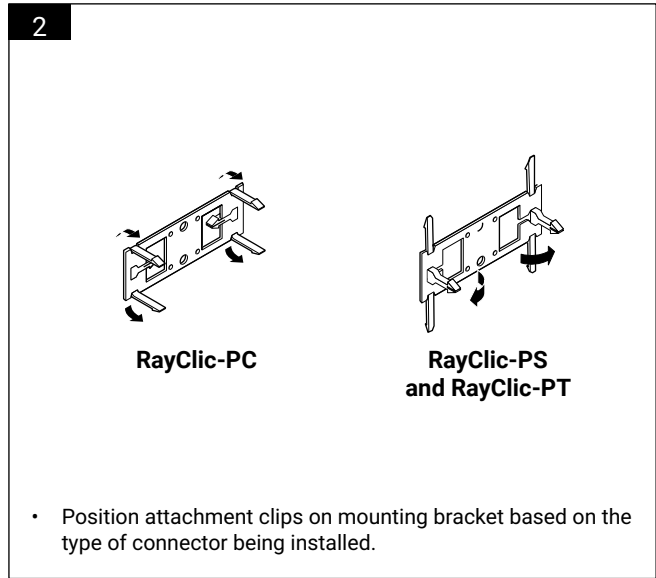
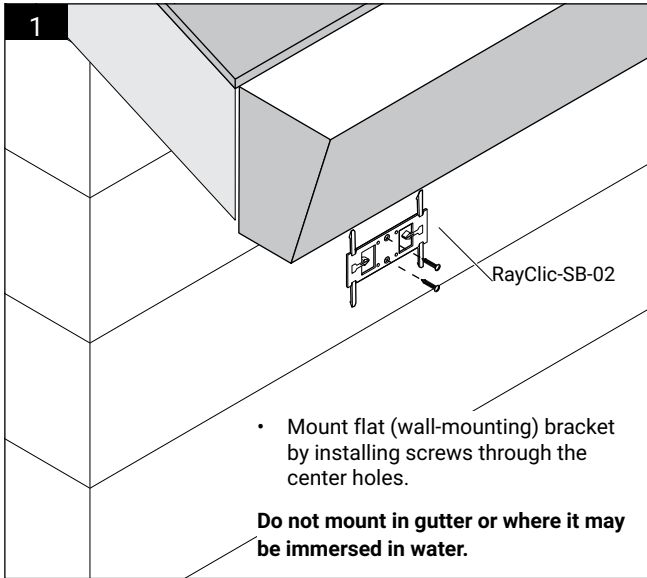

END SEAL INSTALLATION

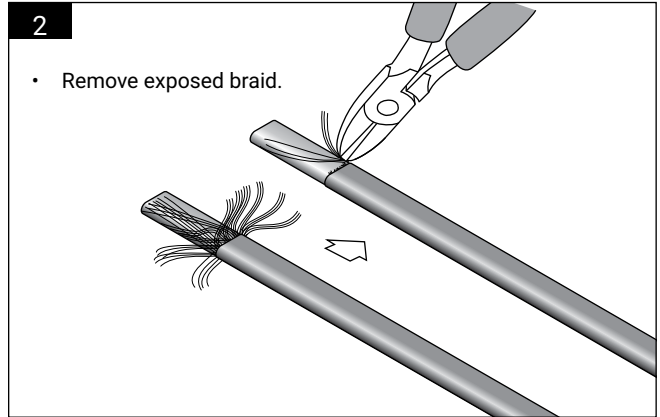
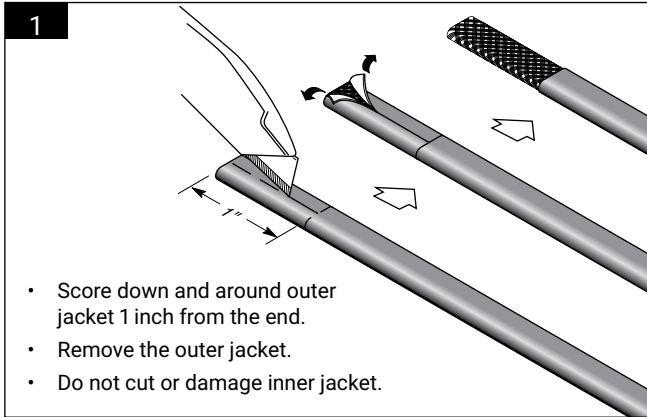

HWAT

IceStop, XL-Trace Edge, and RaySol

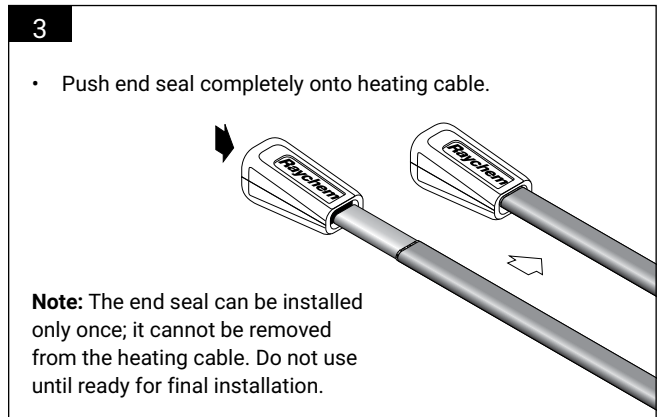
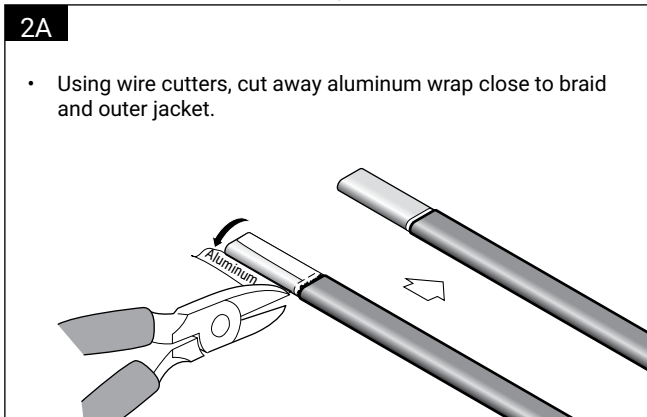

TROUBLESHOOTING GUIDE

Problem	Solution
Braid clips are missing.	The braid clips are attached to the cardboard packing insert under the lid. The braid clips must be used to ensure a ground connection. If clips are missing or lost, call nVent at (800) 545-6258.
Mounting bracket is missing.	A pipe mounting bracket is supplied with the Power Connection, Powered Splice and Powered Tee kits. A wall mounting bracket or additional pipe mounting bracket may be ordered using one of the catalog numbers listed under "Optional Accessories" on the front page of these instructions when you place your order.
Connector does not snap onto bracket.	The bracket has two sets of attachment clips. Fold up the four outer clips for the Power Connection kit. Fold up only the center clips for the Powered Splice and Powered Tee kits.
Heating cable type not mentioned.	nVent RAYCHEM RayClic connection kits are approved for use only with HWAT, XL-Trace Edge, and IceStop heating cables. Do not use with other heating cables.
Braid clip does not fit.	Be sure the clip is installed on the metal braid, not on the outer jacket.
Heating cable does not have aluminum wrap.	Only HWAT heating cables have the aluminum wrap under the braid. Skip the aluminum wrap removal step for XL-Trace Edge and IceStop heating cables.
Heating cable cannot be inserted into connector.	Check for the following: <ul style="list-style-type: none">• Apply cable lubricant to the heating cable primary (white) jacket.• Outer jacket strip length is 3 1/8 inches.• Braid clip is installed on top of the metal braid, not on the outer jacket.• Braid is pulled back over braid clip.• For HWAT, 1 inch of braid is removed.• Sealing nut is loose (but not removed).• Connection screws are loose.
Lid does not close.	Be sure all screws are fully tightened before closing the lid.
Heating cable cannot be inserted into end seal.	The outer jacket must be removed from the heating cable before the end seal is installed (see the "End Seal Installation" instructions on page 9). Make sure 1 inch of the outer jacket, braid, and aluminum wrap (HWAT only) are removed.
Heating cable cannot be removed.	The power connection and end seal are designed to be installed only once; the heating cable cannot be removed once installed. Additional nVent RAYCHEM RayClic -E end seals can be ordered from nVent.

HEATING CABLE CIRCUIT TESTING

The RayClic Power Connection Kits (RayClic-PC, RayClic-PS and RayClic-PT) now include test ports in the blank module. Voltage can be measured at these points to confirm continuity or power to the installed heating cable circuit. For detail heating cable operation refer to the appropriate installation and operating manual.

Instructions:

1. Open the RayClic Cover.
2. Set multimeter to AC voltage function.
3. Insert multimeter test probes into the two test ports.

⚠ WARNING: To avoid shock do not cross the test probes or touch them to the metal pressure plate when measuring voltage.

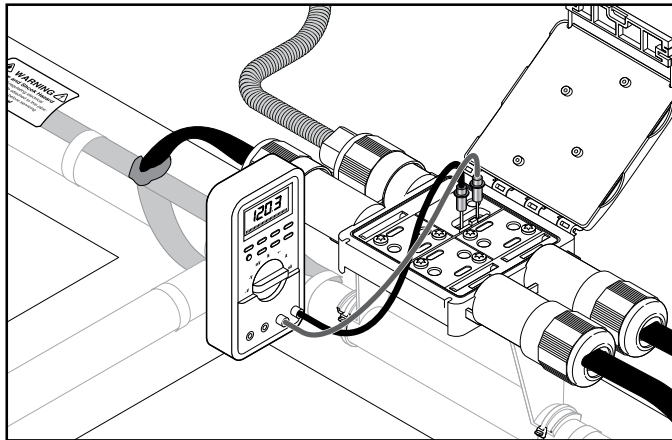
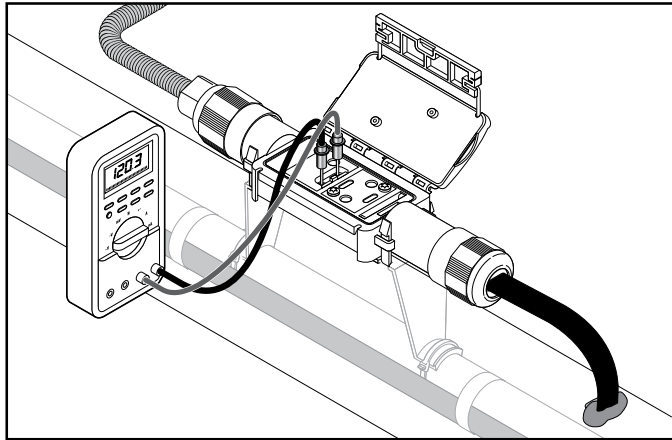
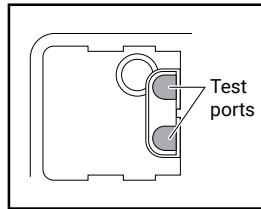

North America

Tel +1.800.545.6258
Fax +1.800.527.5703
thermal.info@nVent.com

Europe, Middle East, Africa

Tel +32.16.213.511
Fax +32.16.213.604
thermal.info@nVent.com

Asia Pacific

Tel +86.21.2412.1688
Fax +86.21.5426.3167
cn.thermal.info@nVent.com

Latin America

Tel +1.713.868.4800
Fax +1.713.868.2333
thermal.info@nVent.com



nVent.com/RAYCHEM