

CARES Technical Approval Report TA1C-5009

Issue 4



ERICO

LENTON® PLUS Mechanical Rebar Splicing System

Assessment of the
LENTON® PLUS, Taper
Threaded Coupler Product,
Sellafield Ltd Type A Couplers
and Quality System
for Production



**TECHNICAL
APPROVAL**
5009



002

Product

LENTON® PLUS
A12, P13 and P14
couplers for
reinforcing steel

Product approval held by:

ERICO
Jules Verneweg 75
5015 BG
Tilburg
The Netherlands

1 Product Summary

The products are for the mechanical connection of deformed high-yield carbon steel bars for the reinforcement of concrete complying with the requirements of BS4449 grade B500C.

1.1 Scope of Application

LENTON® PLUS A12, P13 and P14 couplers, in the size range 16mm-50mm, have been evaluated for use as follows:

- Static tension applications in accordance with CARES Appendix TA1-C, Sellafield Specification for Couplers for Type A mechanical splices using grade B500C reinforcement.
- BS8110 for static use in tension only.

1.2 Design Considerations

BS 8110 Clause 3.12.8.9 Laps and Joints states "Connections transferring stress may be lapped, welded or joined with mechanical devices. They should be placed, if possible, away from points of high stress and should preferably be staggered". However, BS 8110 Clause 3.12.8.16.2 Bars in tension states "The only acceptable form of full-strength butt joint for a bar in tension comprises a mechanical coupler" satisfying specified slip and tensile strength criteria.

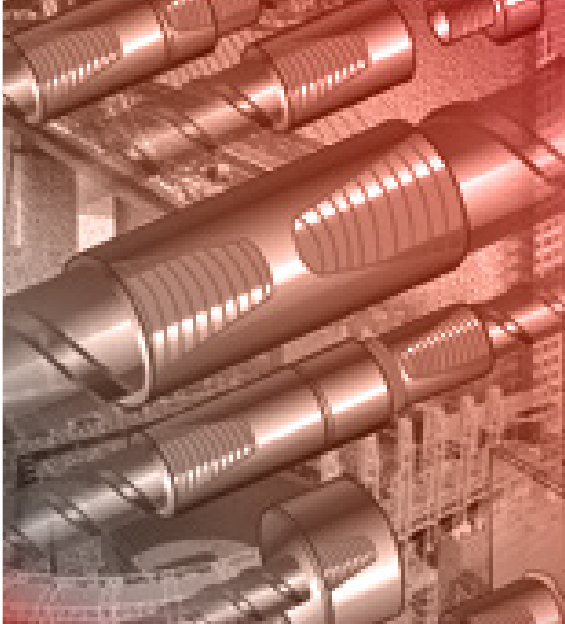

Electronic Copy www.ukcares.com

Eurocode 2, Clause 8.7 Laps and mechanical couplers 8.7.1 General (1)P "Forces are transmitted from one bar to another by:

- lapping of bars, with or without bends or hooks;
- welding;
- mechanical devices assuring load transfer in tension-compression or in compression only."

Clause 8.8 Additional rules for large diameter bars goes on to state that "Splitting forces are higher and dowel action is greater with the use of large diameter bars. Such bars should be anchored with mechanical devices."

The specified cover for fire resistance and durability should be provided to the coupler sleeve. All couplers have been designed with controlled mechanical properties to be compatible with reinforcing bars complying with BS4449 Grade B500C as indicated in tables 1 - 3.

1.3 Conclusion

It is the opinion of UK CARES that LENTON® PLUS A12, P13 and P14 couplers are satisfactory for use within the stated limits when applied and used in accordance with the manufacturer's instructions and the requirements of this certificate.

L. Brankley
Chief Executive Officer

November 2019



2 Technical Specification

2.1 General

LENTON® PLUS A12, P13 and P14 taper threaded couplers are for joining deformed reinforcing bars complying with BS 4449 grade B500C as detailed in tables 1-3.

2.2 LENTON® Type A12

The coupler are a one piece section with a taper thread machined in each end. Coupler size 16 and 20 have a hex shaped cross section, coupler size 25 to 50mm have a circular in cross section.

Standard A12 Coupler

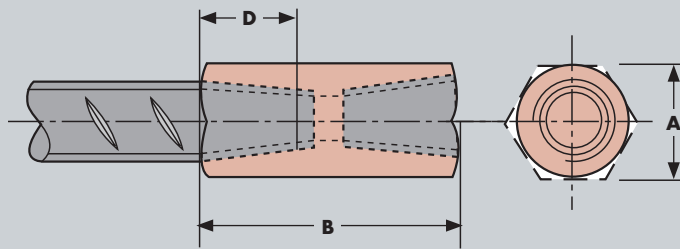

KEY

- A = diameter
- B = length of coupler body
- D = bar engagement

Dimensions for the A12 coupler

Size mm	Part No	Art No	"A" mm	"B" mm	"D" mm	Weight kg	TA1C B500C tension only	Installation torque Nm
16	EL16A12	150030	22*	61	24	0.12	✓	120
20	EL20A12	150050	27*	88	35	0.26	✓	180
25	EL25A12	150070	33	96	40	0.35	✓	270
32	EL32A12	150100	42	107	45	0.60	✓	300
40	EL40A12	150140	52	131	57	1.12	✓	350
50	EL50A12	150160	64	163	70	2.00	✓	650

Table 1

*hexagon (measured across the flats)

2.3 Types P13 and P14

The P13 and P14 three-piece positional couplers are for use where neither of the bars to be coupled can be rotated and are restricted in their axial direction. The three components comprise circular section male and female ends with internal taper threads, connected by female and male parallel threads and locknut.

The male section is hexagonal in cross section for 16 to 20mm couplers and round in cross section for 25 to 50mm. The female section is hexagonal in cross section for 16mm couplers and circular in cross section for 20 to 50mm.

KEY

- A = diameter
- B = length of coupler body
- D = bar engagement
- Fc = connector and jam nut (closed position) length Max.
- Fo = connector and jam nut (fully open position installed) length

Positional P13 Coupler

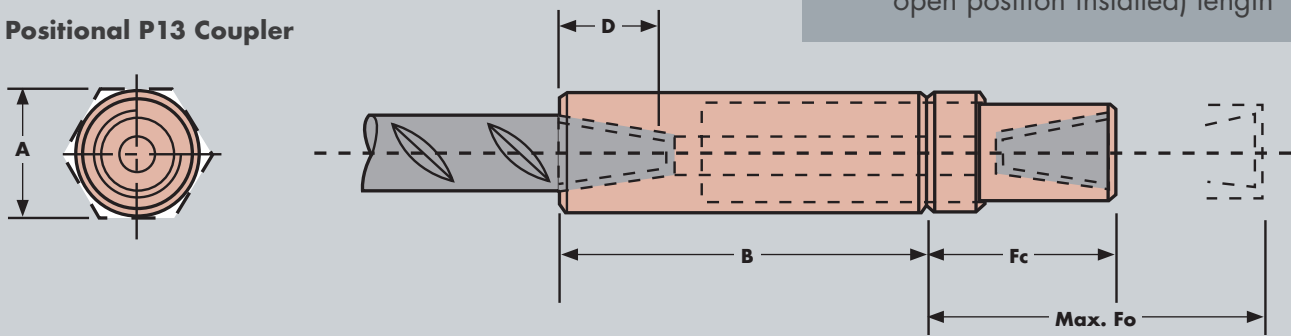

Dimensions for the P13 coupler

Size mm	Part No	Art No	"A" mm	"B" mm	"Fc" mm	"Fo" mm	"D" mm	Weight kg	TA1C B500C tension only	Installation torque Nm
16	EL16P13	150210	27*	88	48	93	24	0.50	✓	120
20	EL20P13	150230	33	112	63	116	35	0.87	✓	180
25	EL25P13	150250	41	127	68	128	40	1.31	✓	270
32	EL32P13	150280	52	144	79	144	45	2.38	✓	300
40	EL40P13	150320	64	179	91	172	57	4.34	✓	350
50	EL50P13	150340	80	214	111	209	70	10.6	✓	350

Table 2

*hexagon (measured across the flats)

Dimensions for the P14 coupler

Size mm	Part No	Art No	"A" mm	"B" mm	"Fc" mm	"Fo" mm	"D" mm	Weight kg	TA1C B500C tension only	Installation torque Nm
16	EL16P14	150390	27*	54	48	59	24	0.35	✓	120
20	EL20P14	150410	33	75	63	79	35	0.64	✓	180
25	EL25P14	150430	41	83	68	84	40	0.96	✓	270
32	EL32P14	150460	52	95	79	95	45	1.77	✓	300
40	EL40P14	150500	64	114	91	107	57	3.07	✓	350

Table 3

*hexagon (measured across the flats)

3 Product Performance and Characteristics

Full destructive tests have been carried out to demonstrate compliance with performance requirements defined in CARES Appendix TA1-C including the performance requirements of BS8110 and the Sellafield Specification for Couplers for Type A mechanical splices when used with reinforcing bars to BS4449 grade B500C:

TA1-C and Sellafield Type A Mechanical Splices

- Permanent deformation is less than 0.1 mm at 300 MPa in tension.
- Tensile strength is greater than $1.15 f_y$, act and less than $1.35 f_y$, act and greater than the load required to produce 2% strain in the reference bars.
- Cyclic loading of 100 cycles between 5% and 90% f_y .
- Reduced temperature performance at -7°C .
- The ultimate tensile strength of the individual splice system shall exceed the actual measured yield strength of the bar by 8%.
- The average effective strain (including permanent elongation of not greater than 0.1 mm after loading to 300 MPa) of the coupled bar measured across the gauge length should not exceed the measured strain across the unspliced bar by more than 40% at all loads up to $0.9 f_y$.
- Failure shall occur by breaking the bar outside the coupler.

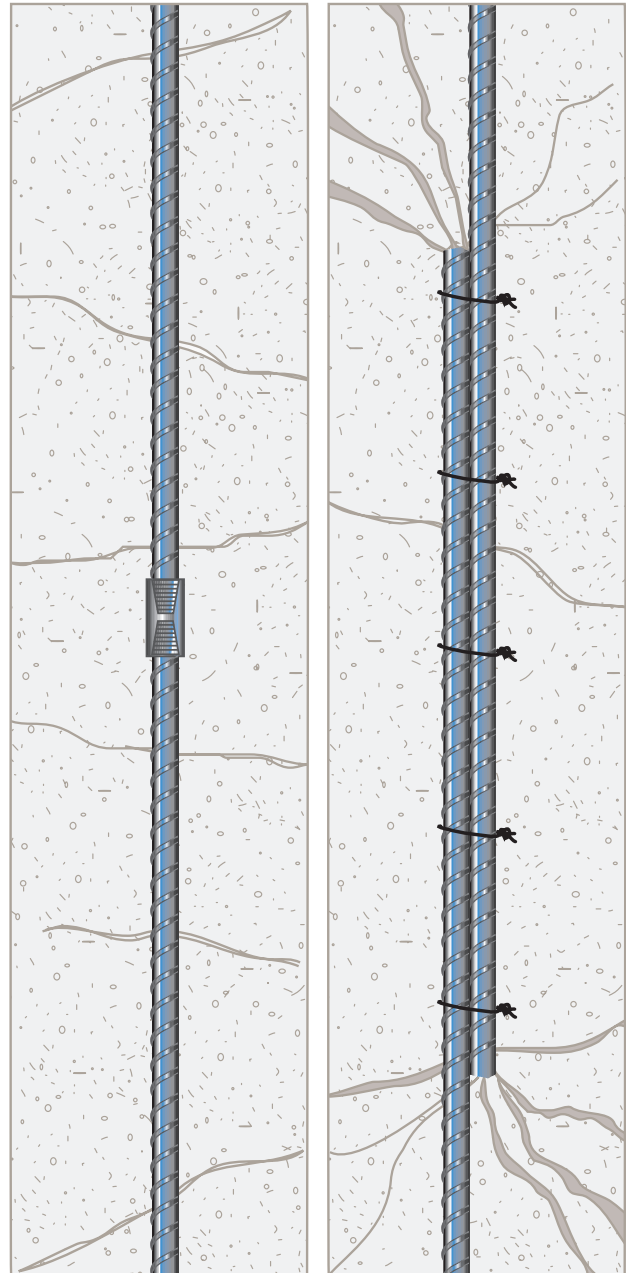

Mechanical splicing provides the assurance of maintaining load path continuity of the structural reinforcement independent of the condition or existence of the concrete

Lap splices rely on bond with the concrete for effective continuity of reinforcement, which can result in localised areas of increased concrete stress that must be considered by the designer

4 Installation

The bars to be threaded must be cut square, swaged and threaded, using LENTON® PLUS equipment and suitably trained and experienced operatives in accordance with LENTON® PLUS operating instructions. These operators will have an LENTON® PLUS Training Certificate. Bars processed under the LENTON® PLUS system shall be identified by yellow markings.

It is essential that the joints be tightened to the correct torque mentioned in the installation manual, using the appropriate LENTON® torque wrench.

The photographs shows the reinforced steel bar before and after processing

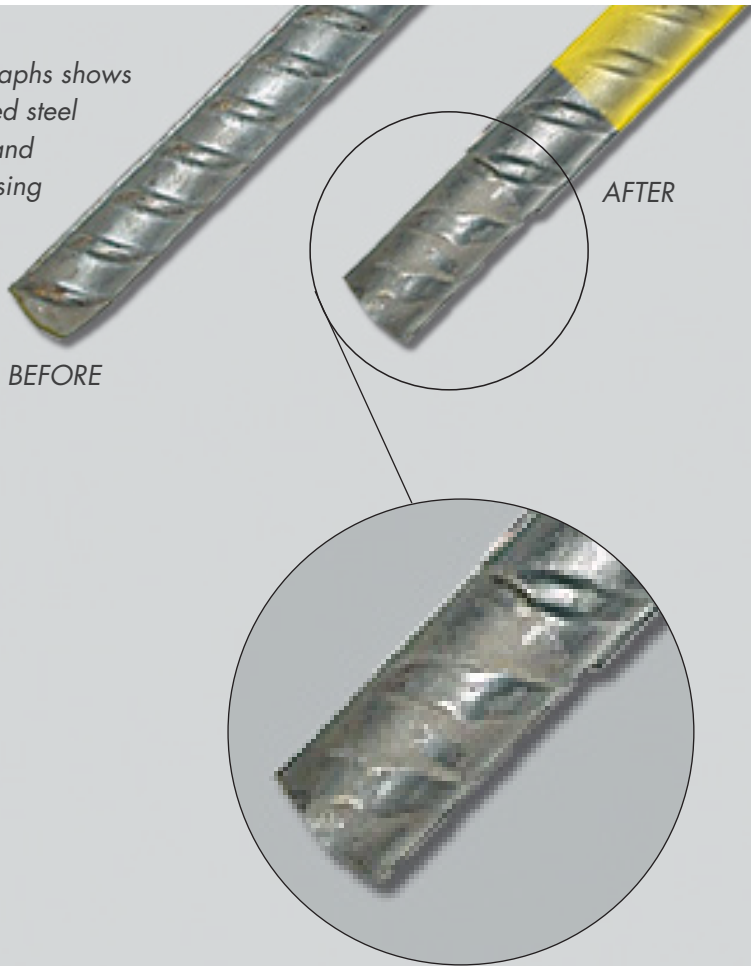

4.1 Type A12 Coupler

These are for connecting reinforcing bars where one of the bars forming the splice is free to turn. The parts are screwed together by hand and tightened to the correct torque. Where the coupler forms a stop end, it must be torque tightened to the reinforcing bar. When the joint is to be made the continuation bar is screwed into the coupler by hand and tightened to the correct torque. The continuation bar must be able to rotate freely.

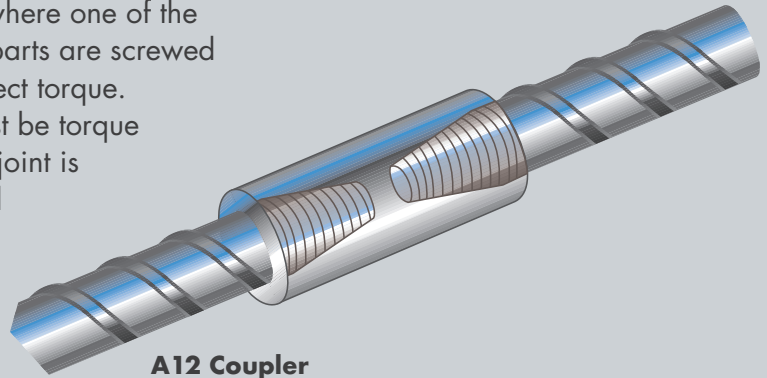

4.2 Type P13 Coupler

These are for connecting cages, crowns of arches, or bars positioned and essentially unable to move. The P13 coupler can actually meet the connecting second bar. It must be ensured that the coupler is fully screwed together and tightened onto the first bar. The cage or other bar is brought into its final position ensuring that the gap between it and the coupler is not greater than 10-25 mm depending on the used size of rebar. The male part is screwed out to engage the tapered thread of the ongoing bar and then fully tightened. The lock-nut is spun back and fully tightened against the body of coupler. It must be ensured that the limit groove is not fully visible above the lock-nut.

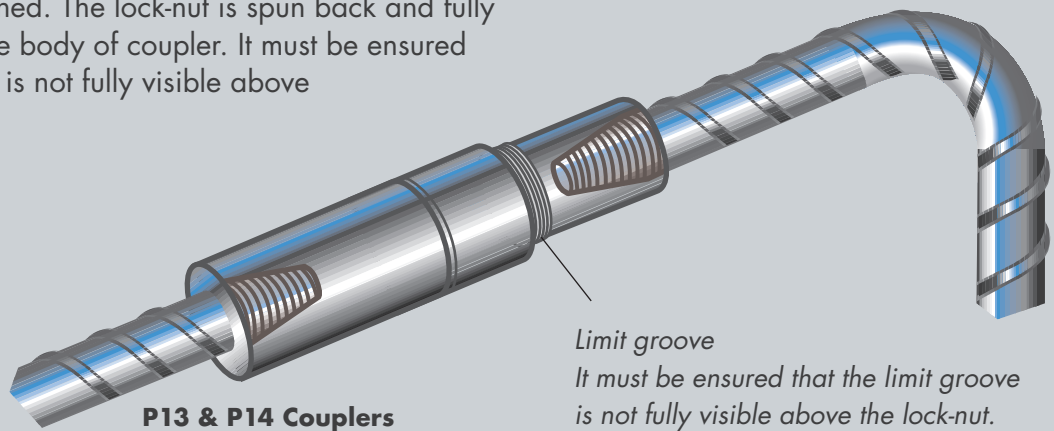

4.3 Type P14 Coupler

These are for connecting onto a bent bar or a bar that cannot be rotated. It must be ensured that the male part is fully screwed into the female part and the female part is tightened onto the first bar. The LENTON® PLUS taper threaded bent bar is inserted into the mouth of the coupler as far as possible. The male part is screwed out of the female part to engage the taper-threaded bar and is tightened. The lock-nut is spun back to coupler body and fully tightened against the coupler body after setting the bent bar to the required position. It must be ensured that the limit groove is not fully visible above the lock-nut.

5 Safety Considerations

Care must be taken in handling and installing couplers. Weight of the containers is based on 25Kg per container. It is advisable to wear protective gloves during handling the containers, threaded bars and installing the couplers.

6 Product Testing and Evaluation

LENTON® PLUS taper threaded couplers have been tested to satisfy the requirements of BS8110 and Sellafield Specification for Couplers for Type A mechanical splices, when used with reinforcing bars to BS4449. The testing comprised the following elements:

BS8110

- Compressive Strength
- Tensile Strength
- Permanent Deformation

Sellafield Specification for Couplers

- Tensile Strength*
- Permanent Deformation*
- Cyclic Loading
- Mode of Failure

* Low temperature testing at -7°C was included

Testing has been undertaken at Stanger Materials Science, the report numbers are listed in Section 9, References.

The products are subject to a programme of periodic testing to ensure that they remain within the performance limits of this technical approval.

7 Quality Assurance

LENTON® PLUS taper thread couplers are produced under an ISO9001: quality management system certified by CARES. The quality assurance scheme monitors the production of the couplers and ensures that materials and geometry remain within the limits of this technical approval.



8 Building Regulations

8.1 The Building Regulations (England and Wales)

Structure, Approved Document A

LENTON® PLUS A12, P13 and P14 taper thread couplers, when used in EC2 based designs using the data contained within this technical approval, satisfy the relevant requirements of The Building Regulations (England and Wales), Approved Document A.

Materials and Workmanship, Approved Document

This technical approval gives assurance that the LENTON® PLUS A12, P13 and P14 taper thread couplers comply with the material requirements of EC2.

8.2 The Building Regulations (Northern Ireland)

Materials and Workmanship

This technical approval gives assurance that LENTON® PLUS A12, P13 and P14 taper thread couplers comply with the material requirements of EC2 by virtue of regulation 23, *Deemed to satisfy provisions regarding the fitness of materials and workmanship*.

8.3 The Building Standards (Scotland)

Fitness of Materials

This technical approval gives assurance that LENTON® PLUS A12, P13 and P14 taper thread couplers comply with the material requirements of EC2 by virtue of *Clause 0.8*.

Structure

LENTON Standard couplers LENTON® PLUS A12, P13 and P14 taper thread couplers, when used in EC2 based designs using the data contained within this technical approval, satisfy the requirements of *The Building Standards (Scotland) clause 1*.

9 References

- BS 4449: 2005: Steel for the reinforcement of concrete - Weldable reinforcing steel - Bar, coil and decoiled product - Specification
- BS 8110: Part 1: 1997 (Revised 2005): Structural Use of Concrete, Code of Practice for Design and Construction
- BS EN 1992-1-1:2004 Eurocode 2 Design of concrete structures - General rules for buildings.
- BS EN ISO 9001: Quality management systems - Requirements
- Sellafield Ltd Technical standard: ES_0_3110_1 - Mechanical Splices and Anchors to Reinforcement for Concrete Part 1 – Design
- Sellafield Ltd Technical standard: ES_0_3110_2 - Mechanical Splices and Anchors to Reinforcement for Concrete Part 2 – Manufacturing, Installation and Construction Requirements
- TA1-C Quality and Operations Schedule for the Technical Approval of Tension Couplers for Reinforcing Steel for Sellafield Standard Applications



10 Conditions

1. The quality of the materials and method of manufacture have been examined by CARES and found to be satisfactory. This technical approval will remain valid provided that:
 - a The product design and specification is unchanged.
 - b The materials, method of manufacture and location are unchanged.
 - c The manufacturer complies with CARES regulations for technical approvals.
 - d The manufacturer holds a valid CARES Certificate of Product Assessment.
 - e The product is installed and used as described in this report.
2. CARES make no representation as to the presence or absence of patent rights subsisting in the product and/or the legal right of ERICO to market the product.
3. Any references to standards, codes or legislation are those which are in force at the date of this certificate.
4. Any recommendations relating to the safe use of this product are the minimum standards required when the product is used. These requirements do not purport to satisfy the requirements of the Health and Safety at Work act 1974 or any other relevant safety legislation.
5. CARES does not accept any responsibility for any loss or injury arising as a direct or indirect result of the use of this product.
6. This Technical Approval Report should be read in conjunction with CARES Certificate of Product Assessment No 5009. Confirmation that this technical approval is current can be obtained from UK CARES.



Electronic Copy www.ukcares.com



UK CARES

Pembroke House
21 Pembroke Road
Sevenoaks
Kent TN13 1XR

Phone: +44(0)1732 450000
E-mail: general@ukcares.com
URL: www.ukcares.com

**Independent Product Assessments
for the Construction Industry**

Copyright UK CARES ©