

CARES Technical Approval Report TA1C - 5030



Issue 5



LENTON

Product approval held by: ERICO

LENTON PLUS Standard, Standard Transition, Position, Position Transition, Parallel Bolt Couplers and Mechanical Anchors

Assessment of the
LENTON PLUS Standard,
Standard Transition,
Position, Position Transition,
Parallel Bolt Couplers
and Mechanical Anchors
Product and Quality
System for Production



Product

LENTON PLUS Standard, Standard Transition A12N couplers, Position P13LN, P14LN couplers and Position Transition P13LN couplers, Parallel Bolt S13N couplers and Mechanical Anchors D14N(W)N and D16N(W)N for reinforcing steel

Product approval held by:

ERICO
Jules Verneweg 75
5015 BG
Tilburg
The Netherlands

1 Product Summary

The products are for the mechanical connection of deformed high-yield carbon steel bars for the reinforcement of concrete complying with the requirements of BS4449 grade B500C. As defined in tables 1 - 8.

1.1 Scope of Application

LENTON PLUS Standard couplers A12N in the size range 12mm-50mm, Standard Transition couplers A12N in the size range 12mm-40mm, Position couplers P13LN and P14LN in the size range 12mm-50mm, Position Transition P13LN couplers in the size 40mm, Parallel Bolt S13N couplers in the size range 12mm-50mm and Mechanical Anchors D14(W)N and D16(W)N in the size range 12mm-50mm have been evaluated for use as follows:

- Static tension applications in accordance with Type A Sellafeld Ltd Specification for Couplers and CARES Appendix TA1-C using B500C reinforcement only.

Note: With regard to the S13N bolt coupler and the D14(W)N and D16(W)N Anchors, this assessment evaluates the performance of the connection between the coupler/anchor and the reinforcing bar and does not consider the bolt or anchorage performance which is matter for the designer.

1.2 Design Considerations

BS 8110 Clause 3.12.8.9 Laps and Joints states “Connections transferring stress may be lapped, welded or joined with mechanical devices. They should be placed, if possible, away from points of high stress and should preferably be staggered”.



However, BS 8110 Clause 3.12.8.16.2 Bars in tension states “The only acceptable form of full-strength butt joint for a bar in tension comprises a mechanical coupler” satisfying specified slip and tensile strength criteria.

Eurocode 2, Clause 8.7 Laps and mechanical couplers 8.7.1 General (1)P “Forces are transmitted from one bar to another by:

- lapping of bars, with or without bends or hooks;
- welding;
- mechanical devices assuring load transfer in tension-compression or in compression only.”

Clause 8.8 Additional rules for large diameter bars goes on to state that “Splitting forces are higher and dowel action is greater with the use of large diameter bars. Such bars should be anchored with mechanical devices.”

The specified cover for fire resistance and durability should be provided to the coupler sleeve. All couplers have been designed with controlled mechanical properties to be compatible with reinforcing bars complying with reinforcement of the relevant Grade in accordance with BS4449.

1.3 Conclusion

It is the opinion of CARES that LENTON PLUS Standard couplers A12N, Standard Transition couplers A12N, Position couplers P13LN and P14LN, Position Transition couplers P13LN, Parallel Bolt couplers S13N and Mechanical Anchor D14(W)N and D16(W)N are satisfactory for use within the stated limits when applied and used in accordance with the manufacturer’s instructions and the requirements of this certificate.

Lee Brankley
 L. Brankley
 Chief Executive Officer
 May 2024



2 Technical Specification

2.1 General

LENTON PLUS Standard, Standard Transition A12N couplers, Position, Position Transition P13LN couplers, Position P14LN couplers and Parallel Bolt S13N are taper threaded couplers for joining deformed Grade B500C reinforcing steel complying with BS4449. LENTON PLUS Mechanical Anchors D14(W)N are for replacing conventional hooked reinforcing steel complying with BS4449.

Part numbers detailed in the following tables are stamped on couplers / anchors. A further suffix and batch identity is also stamped ensuring traceability to the manufacturing unit and production respectively.

2.2 LENTON PLUS Standard A12N

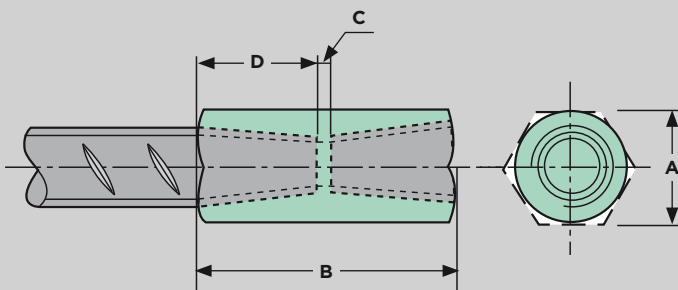

PLUS Standard A12N Coupler

The PLUS standard A12N couplers are designed for use where one of the bars to be coupled can be rotated. The 12mm to 20mm couplers are a one-piece hexagonal section coupler with a tapered thread machined in each end. The 25mm to 50mm diameter couplers are a one-piece circular section with a tapered thread machined in each end. The LENTON standard coupler is designed to splice bars of the same diameter.

The dimensions for the Plus Standard A12N couplers are as follows:

Size mm	Part No**	"A" mm	"B" mm	"D" mm	"C" mm	Weight kg	Colour Plug	Installation Torque Nm
12	EL12A12N	17*	50	19	12	0.06	Red	40
14	EL14A12N	22*	56	21	14	0.13	Green	80
16	EL16A12N	22*	61	24	13	0.13	Black	120
20	EL20A12N	27*	87	35	17	0.27	Yellow	180
25	EL25A12N	35	97	40	17	0.44	Red	270
32	EL32A12N	45	108	45	18	0.79	Yellow	300
40	EL40A12N	55	131	57	17	1.40	Green	350
50	EL50TA12N	70	166	70	26	2.91	Black	350

Table 1

*hexagon (measured across the flats)

**in the case of supply from N America, the N suffix will be omitted

2.3 LENTON PLUS Standard Transition A12N

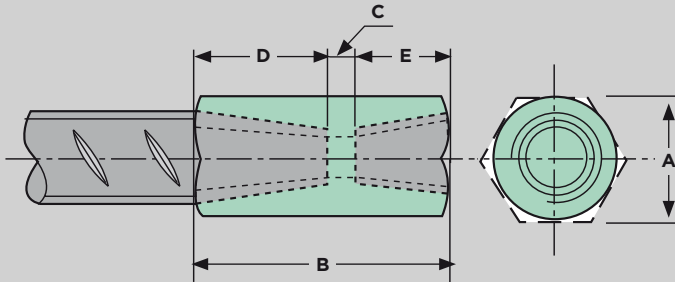

PLUS Standard Transition A12N Coupler

The PLUS standard A12N couplers are designed for use where one of the bars to be coupled can be rotated. The 12mm to 20mm couplers are a one-piece hexagonal section coupler with a tapered thread machined in each end. The 25mm to 40mm diameter couplers are a one-piece circular section with a tapered thread machined in each end. The LENTON standard transition coupler is designed to splice different diameter bars.

The dimensions for the PLUS Standard Transition A12N couplers are as follows:

Size mm	Part No**	"A" mm	"B" mm	"D" mm	"E" mm	"C" mm	Weight kg	Colour Plug	Installation Torque Nm "D"	Installation Torque Nm "E"
14, 12	EL1412A12N	22*	57	21	19	17	0.14	Red	80	40
16, 12	EL1612A12N	22*	61	24	19	18	0.14	Red	120	40
16, 14	EL1614A12N	22*	64	24	21	19	0.14	Green	120	80
20, 12	EL2012A12N	27*	74	35	19	20	0.26	Red	180	40
20, 14	EL2014A12N	27*	77	35	21	21	0.27	Green	180	80
20, 16	EL2016A12N	27*	80	35	24	21	0.27	Black	180	120
25, 12	EL2512A12N	35	81	40	19	22	0.43	Red	270	40
25, 14	EL2514A12N	35	83	40	21	22	0.44	Green	270	80
25, 16	EL2516A12N	35	86	40	24	22	0.45	Black	270	120
25, 20	EL2520A12N	35	98	40	35	23	0.50	Yellow	270	180
32, 16	EL3216A12N	45	92	45	24	23	0.81	Black	300	120
32, 20	EL3220A12N	45	105	45	35	25	0.92	Yellow	300	180
32, 25	EL3225A12N	45	109	45	40	24	0.91	Red	300	270
40, 25	EL4025A12N	55	122	57	40	25	1.56	Red	350	270
40, 32	EL4032A12N	55	126	57	45	24	1.50	Yellow	350	300

Table 2

*hexagon (measured across the flats)

**in the case of supply from N America, the N suffix will be omitted
Tapered Plastic Screw-In Plug, mounted in the smallest side



2.4 LENTON PLUS Position couplers P13LN and P14LN

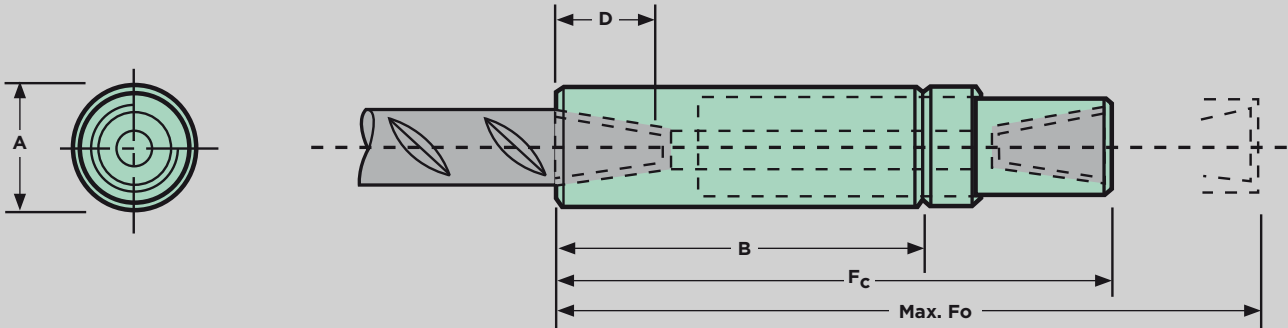

PLUS Positional P13LN and P14LN Coupler

The P13LN and P14LN three-piece position couplers are for use where neither of the bars to be coupled can be rotated. The P13LN coupler is specifically used when the bar to be coupled are also restricted in their axial movement. The P13LN coupler is specifically used when the bar to be coupled are also restricted in their axial movement. The LENTON PLUS position couplers P13LN and P14LN are designed to splice bars of the same diameter. The three components comprise male and female ends with internal taper threads, connected by a female and a male parallel threads and a locknut. Both male section and female section are circular in cross section for 12mm to 50mm couplers.

The dimensions for the P13LN coupler are as follows:

Size mm	Part No*	"A" mm	"B" mm	"Fc" mm	"Fo" mm	"D" mm	Weight kg	Colour Plug	Installation Torque Nm
12	EL12P13LN	25	75	49	85	19	0.36	Red	40
14	EL14P13LN	25	82	52	90	21	0.36	Green	80
16	EL16P13LN	30	89	55	97	24	0.59	Black	120
20	EL20P13LN	35	125	73	135	35	1.09	Yellow	180
25	EL25P13LN	45	140	80	146	40	1.94	Red	270
32	EL32P13LN	60	156	93	164	45	3.96	Yellow	300
40	EL40P13LN	70	184	106	190	57	6.18	Green	350
50	EL50TP13LN	90	224	135	230	70	11.97	Black	350

Table 3

*in the case of supply from N America, the N suffix will be omitted

The dimensions for the P14LN coupler are as follows:

Size mm	Part No*	"A" mm	"B" mm	"Fc" mm	"Fo" mm	"D" mm	Weight kg	Colour Plug	Installation Torque Nm
12	EL12P14LN	25	46	51	58	19	0.26	Red	40
14	EL14P14LN	25	51	54	61	21	0.26	Green	80
16	EL16P14LN	30	54	58	64	24	0.44	Black	120
20	EL20P14LN	35	76	76	88	35	0.76	Yellow	180
25	EL25P14LN	45	86	83	94	40	1.32	Red	270
32	EL32P14LN	60	96	96	107	45	2.72	Yellow	300
40	EL40P14LN	70	112	109	120	57	4.14	Green	350

Table 4

*in the case of supply from N America, the N suffix will be omitted

2.5 LENTON PLUS Position Transition couplers P13LN

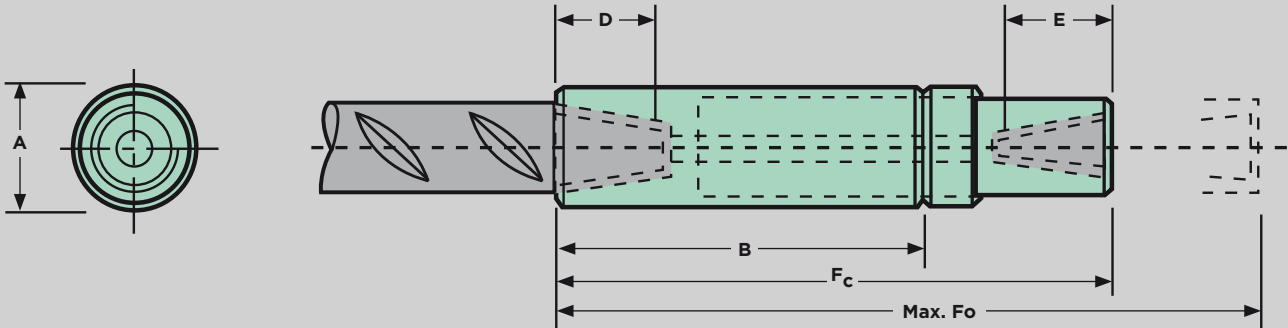

PLUS Positional Transition P13LN Coupler

The P13LN three-piece transition couplers are for use where neither of the bars to be coupled can be rotated. The P13LN coupler is specifically used when the bar to be coupled are also restricted in their axial movement. The LENTON PLUS position transition couplers P13LN is designed to splice different diameter bars. The three components comprise male and female ends with internal taper threads, connected by a female and a male parallel threads and a locknut. Both male section and female section are circular in cross section.

The dimensions for the PLUS Standard Transition P13LN coupler are as follows:

Size mm	Part No*	"A" mm	"B" mm	"Fc" mm	"Fo" mm	"D" mm	"E" mm	Weight kg	Colour Plug	Installation Torque Nm "D"	Installation Torque Nm "E"
50, 40	EL50T40P13LN 90	90	224	358	454	70	57	13	Green	350	350

Table 5

*in the case of supply from N America, the N suffix will be omitted

Electronic Copy www.carescertification.com



2.6 LENTON PLUS Parallel Bolt couplers S13N

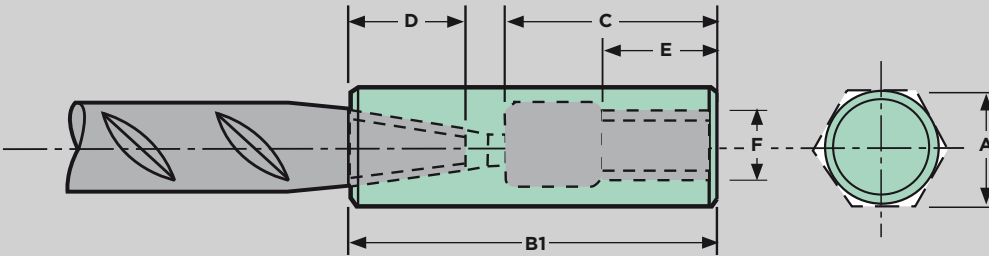

PLUS Parallel Bolt Coupler S13N

The parallel bolt coupler S13N is designed to provide a full strength joint between a reinforcing steel bar and ISO® 965 metric all-thread rod or bolt. The 12mm to 16mm couplers are one-piece hexagonal section couplers with a tapered thread machined in one end and a metric machined thread in the other end. The 20mm to 50mm diameter couplers are one-piece circular section coupler with a tapered thread machined in one end and a metric machined thread in the other end.

The dimensions for the S13N coupler are as follows:

Size mm	Part No**	"A" mm	"B1" mm	"E" mm	"C" mm	"F" mm	"D" mm	Weight kg	Colour Plug	Installation Torque Nm
12	EL12S13N	22*	58	19	33	M16x2	19	0.12	Natural	40
14	EL14S13N	27*	63	21	35	M18x2.5	21	0.12	Natural	80
16	EL16S13N	27*	68	23	37	M20x2.5	24	0.21	Natural	120
20	EL20S13N	35	98	27	55	M24x3	35	0.48	Natural	180
25	EL25S13N	45	110	33	61	M30x3.5	40	0.90	Natural	270
32	EL32S13N	55	125	43	70	M39x4	45	1.42	Natural	300
40	EL40S13N	65	143	49	77	M45x4.5	57	2.28	Natural	350
50	EL50TS13N	85	171	60	88	M56x5.5	70	4.83	Natural	350

Table 6

*hexagon (measured across the flats)

**in the case of supply from N America, the N suffix will be omitted

2.7 LENTON PLUS Mechanical Anchor D14(W)N and D16(W)N

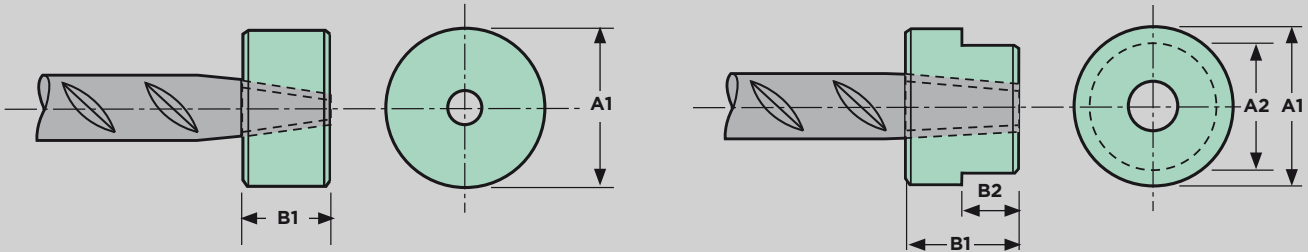

PLUS Mechanical Anchor D14(W)N and D16(W)N

The mechanical anchor D14(W)N and D16(W)N is designed to replace conventional hooked reinforcing steel bar. The 12mm to 50mm couplers are one-piece round section couplers with a machined tapered thread hole.

The dimensions for the PLUS Mechanical Anchor D14(W)N coupler are as follows:

Size mm	Part No*	"A1" mm	"A2" mm	"B1" mm	"B2" mm	Weight kg	Installation Torque Nm
12	EL12D14N	45	-	18	-	0.21	40
14	EL14D14N	45	-	21	-	0.24	80
16	EL16D14N	55	-	24	-	0.41	120
20	EL20D14N	65	-	35	-	0.83	180
25	EL25D14N	80	-	40	-	1.43	270
32	EL32D14WN	105	80	45	25	2.11	300
40	EL40D14WN	130	80	57	25	3.82	350
50	EL50TD14WN	160	80	70	25	7.07	350

Table 7

*in the case of supply from N America, the N suffix will be omitted

The dimensions for the PLUS Mechanical Anchor D16(W)N coupler are as follows:

Size mm	Part No**	"A1" mm	"A2" mm	"B1" mm*	"B2" mm	Weight kg	Installation Torque Nm
12	EL12D16N	35	-	19	-	0.12	40
14	EL14D16N	35	-	22	-	0.14	80
16	EL16D16N	36	-	24	-	0.16	120
20	EL20D16N	45	-	35	-	0.37	180
25	EL25D16N	60	-	40	-	0.76	270
32	EL32D16N	75	-	46	-	1.33	300
40	EL40D16WN	90	80	57	25	2.11	350
50	EL50TD16WN	115	80	70	25	3.69	350

Table 8

*B1 equals engagement length between coupler and bar

**in the case of supply from N America, the N suffix will be omitted

3 Product Performance and Characteristics

Full destructive tests have been carried out to demonstrate compliance with performance requirements defined in CARES Appendix TA1-C including the performance requirements of Eurocode 2 and the Sellafield Specification for Couplers for Type A mechanical splices when used with reinforcing bars to BS4449 grade B500C:

TA1-C and Sellafield Type A Mechanical Splices

- Tensile strength is greater than $1.15 f_{y,act}$ and less than $1.35 Re_{(act)}$ (Actual yield strength) and greater than the load required to produce 2% strain in the reference bars.
- Cyclic loading of 100 cycles between 5% and 90% $Re_{(char)}$ (Characteristic yield strength of the bar).
- Cold soak testing at $-7^{\circ}C$.
- Permanent elongation is less than 0.10mm after unloading from $0.65 Re_{(char)}$.
- The average effective strain of the coupled bar measured across the gauge length should not exceed the measured strain across the unspliced bar by more than 40% at all loads up to $0.9 Re_{(char)}$ (except in the case of the cold soak test).
- Failure shall occur by breaking the bar outside the coupler.

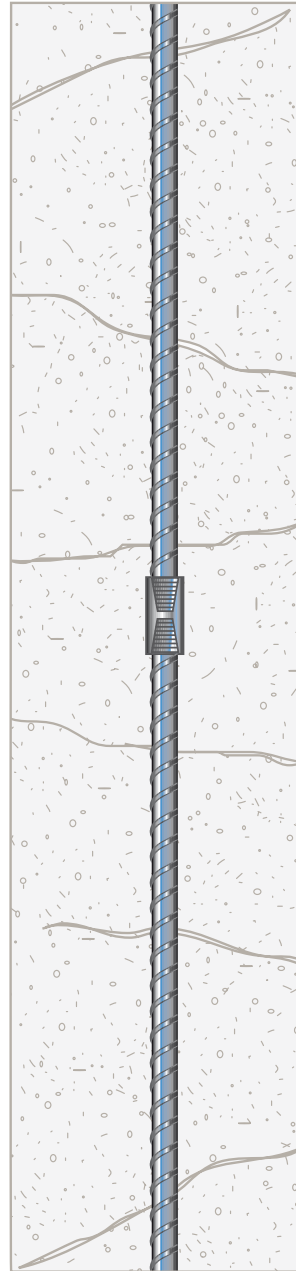

Mechanical splicing provides the assurance of maintaining load path continuity of the structural reinforcement independent of the condition or existence of the concrete

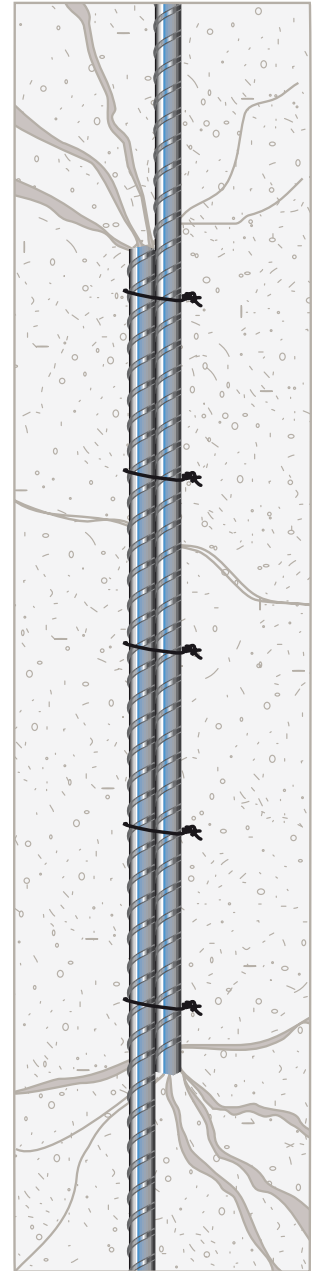

Lap splices rely on bond with the concrete for effective continuity of reinforcement, which can result in localised areas of increased concrete stress that must be considered by the designer

4 Installation

The bars to be threaded must be cut square, swaged and threaded, using LENTON PLUS equipment and suitably trained and experienced operatives in accordance with LENTON PLUS operating instructions. These operators will have received LENTON PLUS equipment training. Bars processed under the LENTON PLUS system shall be identified by yellow markings.

It is essential that the joints be tightened to the correct torque mentioned in the installation manual, using the appropriate LENTON torque wrench.

The photographs show the reinforced steel bar before and after processing



Electronic Copy www.carescertification.com



4.1 LENTON PLUS Standard coupler A12N

A12N Standard couplers are for connecting reinforcing bars where one of the bars forming the splice is free to turn. The parts are screwed together by hand and tightened to the correct torque. Where the coupler forms a stop end, it must be torque tightened to the reinforcing bar. When the joint is to be made the continuation bar is screwed into the coupler by hand and tightened to the correct torque. The continuation bar must be able to rotate freely.

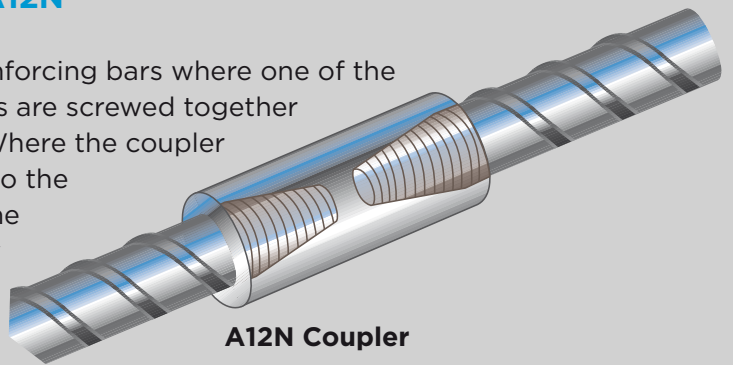

A12N Coupler

4.2 LENTON PLUS Standard Transition coupler A12N

A12N Standard Transition couplers are for connecting different diameter reinforcing bars where one of the bars forming the splice is free to turn. The parts are screwed together by hand and tightened to the correct torque. Where the coupler forms a stop end, it must be torque tightened to the reinforcing bar. When the joint is to be made the continuation bar is screwed into the coupler by hand and tightened to the correct torque. The continuation bar must be able to rotate freely.

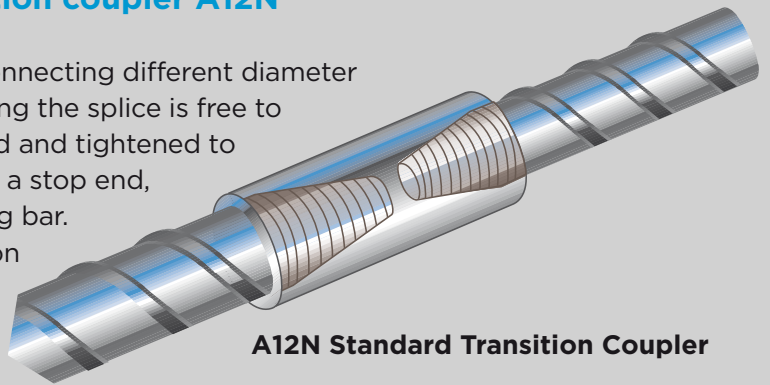

A12N Standard Transition Coupler

4.3 LENTON PLUS Position and Position Transition coupler P13LN

P13LN Couplers are for connecting cages, crowns of arches, or bars positioned and essentially unable to move. The P13LN coupler can be adjusted in length to connect to the second bar. It must be ensured that the coupler is fully screwed together and tightened onto the first bar. The cage or other bar is brought into its final position ensuring that the gap between it and the coupler is not greater than 10mm - 25 mm depending on the used size of rebar. The male part is screwed out to engage the tapered thread of the ongoing bar and then fully tightened. The lock-nut is spun back and fully tightened against the body of coupler. It must be ensured that the limit groove on the male section is not fully visible above the lock-nut.

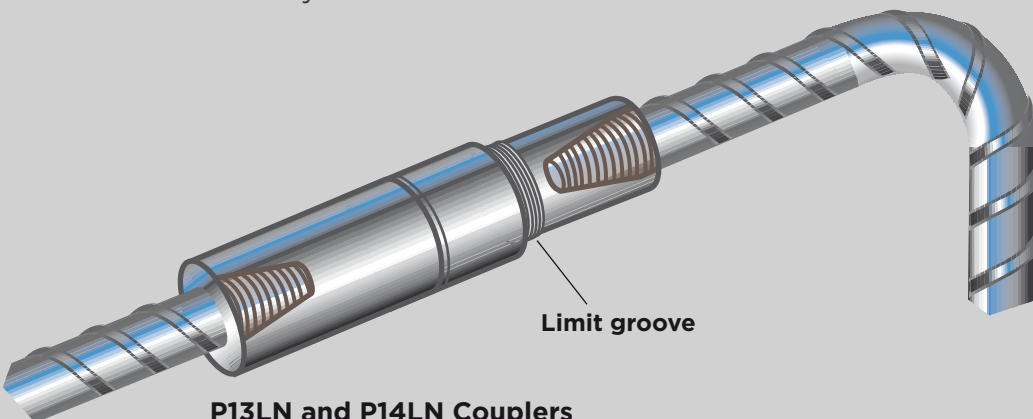

P13LN and P14LN Couplers

4.4 LENTON PLUS Position coupler P14LN

P14LN couplers are for connecting onto a bent bar or a bar that cannot be rotated. It must be ensured that the male part is fully screwed into the female part and the female part is tightened onto the first bar. The taper-threaded bent bar is inserted into the mouth of the coupler as far as possible. The male part is screwed out of the female part to engage the taper-threaded bar and is tightened. The lock-nut is spun back to coupler body and fully tightened against the coupler body after setting the bent bar to the required position. It must be ensured that the limit groove is not fully visible above the lock-nut.

4.5 LENTON PLUS Parallel Bolt couplers S13N

S13N couplers are for connecting a metric all-thread rod or bolt to reinforcing bar to where either the reinforcing bar or all metric rod (or bolt) forming the splice is free to turn. The parts are screwed together by hand and tightened to the correct torque. Where the coupler forms a stop end, it must be torque tightened to the reinforcing bar. When the joint is to be made the continuation metric rod or bolt is screwed into the coupler by hand. The metric rod or bolt must be able to rotate freely.

4.6 LENTON PLUS Mechanical Anchor D14(W)N and D16(W)N

D14(W)N and D16(W)N anchors are for replacing conventional hooked reinforcing bar. The bar replacing the hooked bar is not free to turn. The anchor is screwed to the bar by hand and tightened to the correct torque.



5 Safety Considerations

Care must be taken in handling and installing couplers. Couplers are supplied in boxes that have a maximum weight of 25kg. Wear protective gloves during handling the boxes, threaded bars and installing the couplers.

6 Product Testing and Evaluation

LENTON PLUS Standard couplers A12N, Standard Transition couplers A12N, Position couplers P13LN and P14LN, Position Transition couplers P13LN, Parallel Bolt couplers S13N and Mechanical Anchor D14(W)N and D16(W)N have been tested to satisfy the requirements of Eurocode 2 and Sellafield Ltd.

Specification for couplers, when used with reinforcing bars grade 500C to BS4449.

The testing comprised the following elements:

Sellafield Ltd Specification for Couplers

- Tensile Strength*
- Cyclic Loading
- Permanent Deformation*
- Effective strain*
- Mode of failure*

*Low temperature testing at -7°C was included

The products are subject to a programme of periodic testing to ensure that they remain within the performance limits of this technical approval.

7 Quality Assurance

LENTON PLUS taper thread couplers are produced under an ISO 9001 quality management system certified by an independent certification body. The quality assurance scheme monitors the production of the couplers and ensures that materials and geometry remain within the limits of this technical approval.

8 Building Regulations

8.1 The Building Regulations (England and Wales)

Structure, Approved Document A

LENTON PLUS Standard couplers A12N, Standard Transition couplers A12N, Position couplers P13LN and P14LN, Position Transition couplers P13LN, Parallel Bolt couplers S13N and Mechanical Anchor D14(W)N and D16(W)N, when used in EC2 based designs using the data contained within this technical approval, satisfy the relevant requirements of The Building Regulations (England and Wales), Approved Document A.

Materials and Workmanship, Approved Document

This technical approval gives assurance that the LENTON PLUS Standard couplers A12N, Standard Transition couplers A12N, Position couplers P13LN and P14LN, Position Transition couplers P13LN, Parallel Bolt couplers S13N and Mechanical Anchor D14(W)N and D16(W)N comply with the material requirements of EC2.

8.2 The Building Regulations (Northern Ireland)

Materials and Workmanship

This technical approval gives assurance that LENTON PLUS Standard couplers A12N, Standard Transition couplers A12N, Position couplers P13LN and P14LN, Position Transition couplers P13LN, Parallel Bolt couplers S13N and Mechanical Anchor D14(W)N and D16(W)N comply with the material requirements of EC2 by virtue of regulation 23, *Deemed to satisfy provisions regarding the fitness of materials and workmanship.*

8.3 The Building Standards (Scotland)

Fitness of Materials

This technical approval gives assurance that LENTON PLUS Standard couplers A12N, Standard Transition couplers A12N, Position couplers P13LN and P14LN, Position Transition couplers P13LN, Parallel Bolt couplers S13N and Mechanical Anchor D14(W)N and D16(W)N comply with the material requirements of EC2 by virtue of *Clause 0.8.*

Structure

LENTON PLUS Standard couplers A12N, Standard Transition couplers A12N, Position couplers P13LN and P14LN, Position Transition couplers P13LN, Parallel Bolt couplers S13N and Mechanical Anchor D14(W)N and D16(W)N, when used in EC2 based designs using the data contained within this technical approval, satisfy the requirements of *The Building Standards (Scotland) clause 1.*



9 References

- BS 4449: 2005: Steel for the reinforcement of concrete - Weldable reinforcing steel - Bar, coil and decoiled product - Specification
- BS 8110: Part 1: 1997 (Revised 2005): Structural Use of Concrete, Code of Practice for Design and Construction
- BS EN 1992-1-1:2004 Eurocode 2: Design of concrete structures. General rules and rules for buildings
- BS EN ISO 9001: Quality management systems -Requirements
- Sellafield Ltd Technical standard: ES_O_3110_1 - Mechanical Splices and Anchors to Reinforcement for Concrete Part 1 - Design
- Sellafield Ltd Technical standard: ES_O_3110_2 - Mechanical Splices and Anchors to Reinforcement for Concrete Part 2 - Manufacturing, Installation and Construction Requirements
- TA1-C Quality and Operations Schedule for the Technical Approval of Tension Couplers for Reinforcing Steel for Sellafield Ltd Standard Applications

10 Conditions

1. The quality of the materials and method of manufacture have been examined by CARES and found to be satisfactory. This technical approval will remain valid provided that:
 - a The product design and specification is unchanged.
 - b The materials, method of manufacture and location are unchanged.
 - c The manufacturer complies with CARES regulations for technical approvals.
 - d The manufacturer holds a valid CARES Certificate of Product Assessment.
 - e The product is installed and used as described in this report.
2. CARES make no representation as to the presence or absence of patent rights subsisting in the product and/or the legal right of ERICO to market the product.
3. Any references to standards, codes or legislation are those which are in force at the date of this certificate.
4. Any recommendations relating to the safe use of this product are the minimum standards required when the product is used. These requirements do not purport to satisfy the requirements of the Health and Safety at Work act 1974 or any other relevant safety legislation.
5. CARES does not accept any responsibility for any loss or injury arising as a direct or indirect result of the use of this product.
6. This Technical Approval Report should be read in conjunction with CARES Certificate of Product Assessment No 5030. Confirmation that this technical approval is current can be obtained from CARES.





Electronic Copy www.carescertification.com

CARES

Pembroke House
21 Pembroke Road
Sevenoaks
Kent TN13 1XR

Phone: +44(0)1732 450000
E-mail: general@carescertification.com
www.carescertification.com



**Independent Product Assessments
for the Construction Industry**

Copyright CARES ©