

CARES Technical Approval Report TA1-F 5081



Issue 2



LENTON

Product approval held by:
ERICO Europe

LENTON A2(N) Standard, Transitional and P14LN Position Couplers

Assessment of the
LENTON A2(N)
Standard, Transitional
and P14LN Position
Coupler Product
and Quality System
for Production



TECHNICAL
APPROVAL
5081



0002



Validate with the
CARES Cloud App

Product

LENTON A2(N) Standard, Transitional and P14LN Position Couplers for reinforcing steel

Product approval held by:

ERICO Europe
Jules Verneweg 75
5015 BG
Tilburg
The Netherlands

1 Product Summary

LENTON A2(N) and P14LN Couplers in the size range as detailed in tables 1, 2 and 3 are for the mechanical connection of deformed high-yield carbon steel bars for the reinforcement of concrete complying with the requirements of BS4449 Grade B500B.

By agreement, this Technical Approval is not valid in the United Kingdom, as it acknowledges that the UK Standards Committee rejected ISO15835:2018 during the public comment phase of its introduction.

The introduction of the TA1-F appendix by CARES is to facilitate a Technical Approval scheme incorporating a testing method for couplers in geographical areas where no national approval schemes currently exist.

1.1 Scope of Application

LENTON A2(N) and P14LN Couplers in the size range as detailed in tables 1, 2 and 3 have been evaluated for use as follows:

- a) TA1-F: Eurocode 2 for static applications in tension only with BS4449 Grade B500B reinforcement.
- b) ISO15835-1:2018 Steels for the reinforcement of concrete - Reinforcement couplers for mechanical splices of bars - requirements Type B coupler under predominantly static loads in tension only using BS4449 Grade B500B reinforcement.

1.2 Design Considerations

Eurocode 2, Clause 8.7 Laps and mechanical couplers 8.7.1 General (1)P "Forces are transmitted from one bar to another by:

- lapping of bars, with or without bends or hooks;
- welding;
- mechanical devices assuring load transfer in tension-compression or in compression only."

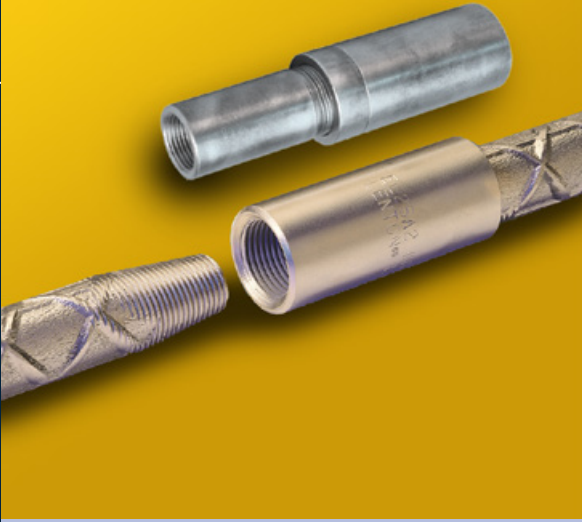

Clause 8.8 Additional rules for large diameter bars goes on to state that “Splitting forces are higher and dowel action is greater with the use of large diameter bars. Such bars should be anchored with mechanical devices.”

The specified cover for fire resistance and durability should be provided to the coupler sleeve. All couplers as detailed in tables 1, 2 and 3 have been designed with controlled mechanical properties to be compatible with reinforcing bars complying with BS4449 Grade B500B.

1.3 Conclusion

It is the opinion of CARES that LENTON A2(N) and P14LN Couplers in the size range as detailed in tables 1, 2 and 3 are satisfactory for use within the limits stated in paragraph 1.1 when applied and used in accordance with the manufacturer’s instructions and the requirements of this certificate.

L. Brankley
 Chief Executive Officer
 July 2024

Electronic Copy www.carescertification.com



2 Technical Specification

2.1 General

LENTON A2(N) Standard, Transitional and P14LN Position Couplers are for joining deformed Grade B500B steel reinforcing bars complying with BS4449.

Part numbers detailed in the following tables are stamped on couplers / anchors. A further suffix and batch identity is also stamped ensuring traceability to the manufacturing unit and production respectively.

2.2 LENTON A2(N) Standard Couplers

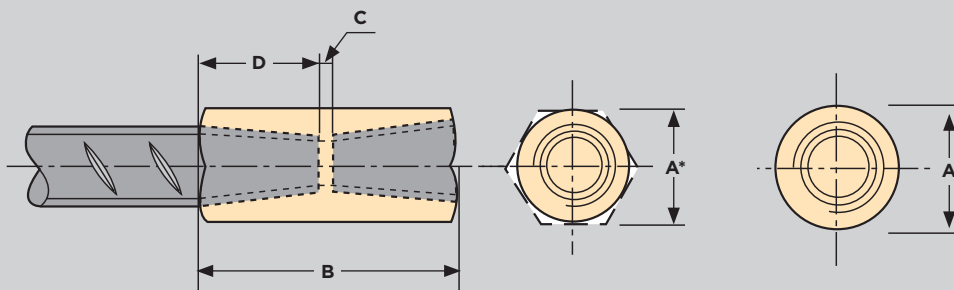

A2(N) Standard Coupler

The A2(N) Standard Couplers are designed for use where one of the bars to be coupled can be rotated. The 12mm to 20mm couplers are a one-piece hexagonal section coupler with a tapered thread machined in each end. The 25mm to 50mm diameter couplers are a one-piece circular section with a tapered thread machined in each end. The LENTON Standard coupler is designed to splice bars of the same diameter.

The dimensions for the A2(N) Standard Couplers are as follows:

Size mm	Part No	"A" mm	"B" mm	"C" mm	"D" mm	Weight kg	Colour Plug	Installation Torque Nm
12	EL12A2(N)	17*	42	12	15	0.06	Red	40
16	EL16A2(N)	22*	56	12	22	0.12	Black	120
20	EL20A2(N)	27*	72	16	28	0.23	Yellow	180
25	EL25A2(N)	36	86	18	34	0.43	Red	270
32	EL32A2(N)	45	97	17	40	0.73	Yellow	300
40	EL40A2L(N)	55	131	17	57	1.40	Green	350
50	EL50TA2(N)	70	167	25	71	3	Black	350

Table 1

*hexagon (measured across the flats)

2.3 LENTON A2(N) Standard Transition Couplers

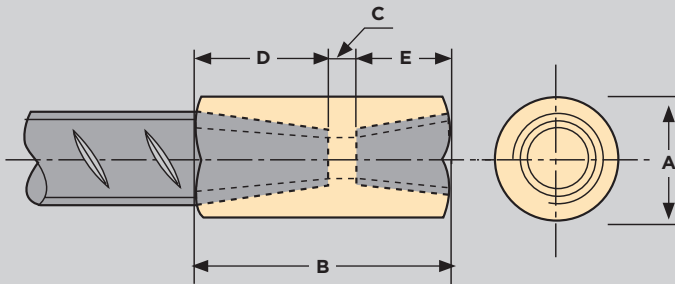

A2(N) Standard Transition Coupler

The A2(N) Standard Transition Couplers are designed for use where one of the bars to be coupled can be rotated. Couplers are a one-piece circular section with a tapered thread machined in each end. The LENTON Standard Transition Coupler is designed to splice different diameter bars.

The dimensions for the A2(N) Standard Transition Couplers are as follows:

Size mm	Part No	"A" mm	"B" mm	"C" mm	"D" mm	"E" mm	Weight kg	Colour Plug	Installation Torque Nm "D"	Installation Torque Nm "E"
25, 20	EL2520A2(N)	36	89	27	34	28	0.51	Yellow	270	180
32, 25	EL3225A2(N)	45	101	27	40	34	0.88	Red	300	270
40, 25	EL4025A2(N)	55	117	28	55	34	1.52	Red	350	270
40, 32	EL4032A2(N)	55	122	27	55	40	1.52	Yellow	350	300

Table 2

Electronic Copy www.carescertification.com

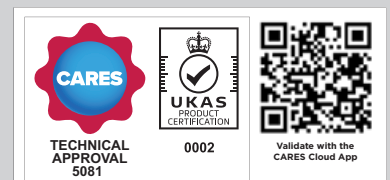

2.4 LENTON P14LN Position couplers

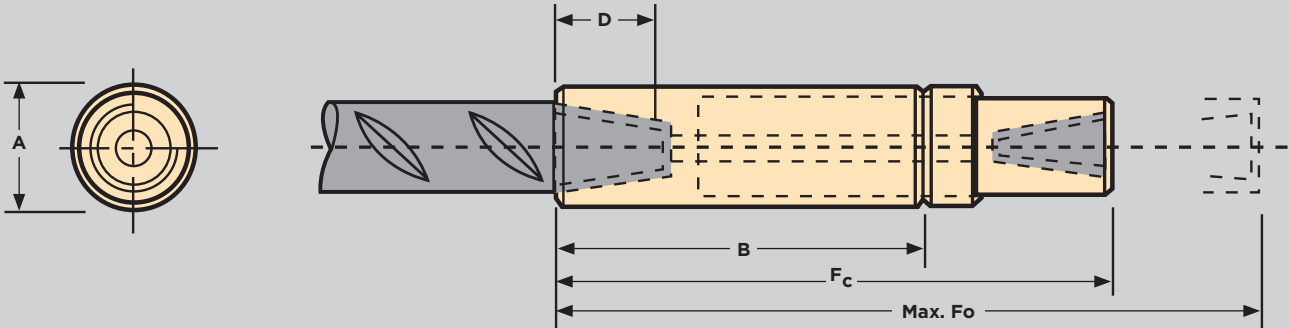

Positional P14LN Coupler

The P14LN three-piece position coupler is for use where neither of the bars to be coupled can be rotated. The three components comprise male and female ends with internal taper threads, connected by female and male parallel threads and a locknut.

Both male section and female section are circular in cross section for 12mm to 40mm couplers.

The dimensions for the P14LN coupler are as follows:

Size mm	Part No*	"A" mm	"B" mm	"Fc" mm	"Fo" mm	"D" mm	Weight kg	Colour Plug	Installation Torque Nm
16	EL16P14LN	30	54	112	119	24	0.44	Black	120
20	EL20P14LN	35	76	152	163	35	0.76	Yellow	180
25	EL25P14LN	45	86	169	180	40	1.32	Red	270
32	EL32P14LN	60	96	192	203	45	2.72	Yellow	300
40	EL40P14LN	70	112	221	232	57	4.14	Green	350
50	EL50TP14LN	90	148	287	308	70	8.52	Black	350

Table 3

*in the case of supply from N America, the N suffix will be omitted

3 Product Performance and Characteristics

Full destructive tests have been carried out to demonstrate compliance with the performance requirements defined in CARES Appendix TA1-F coupler when used with reinforcing steel BS4449 grade B500B as appropriate as detailed in tables 1.

CARES APPENDIX TA1-F strength requirements

- Permanent deformation is less than 0.10mm after loading to 60% of the specified characteristic yield strength value of the reinforcing bar in tension with BS4449 grade B500B reinforcement, tested in accordance with option 2 of ISO15835-1 clause 5.4.1.
- The relaxed slip requirements for couplers longer than 100mm and calculation of slip as a median as defined in ISO 15835-1:2018 clause 5.4.2 is not be permitted for couplers approved under this TA1-F schedule

ISO15835-1:2018 requirements for slip and tensile strength

Tests verify compliance with Clauses 5.3 and 5.4 of ISO15835-1:2018 for the following for a category “B” coupler as defined in table 2:

- slip under static forces; and
- tensile strength and ductility under static forces.

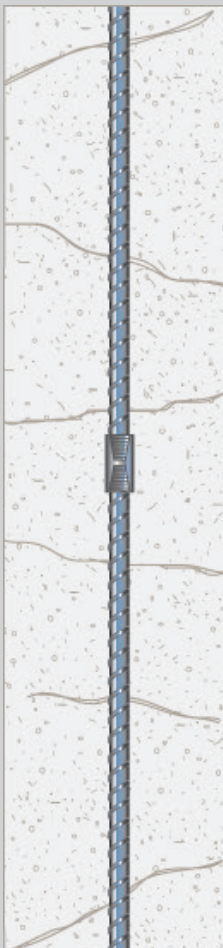

Mechanical splicing provides the assurance of maintaining load path continuity of the structural reinforcement independent of the condition or existence of the concrete

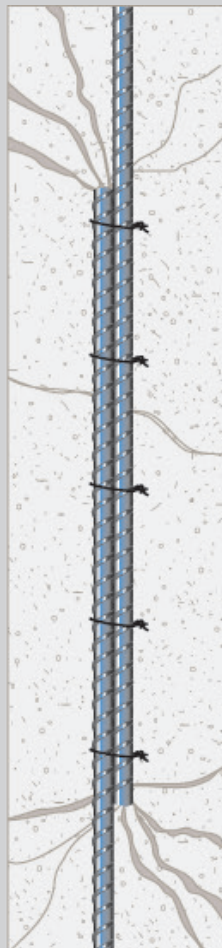

Lap splices rely on bond with the concrete for effective continuity of reinforcement, which can result in localised areas of increased concrete stress that must be considered by the designer

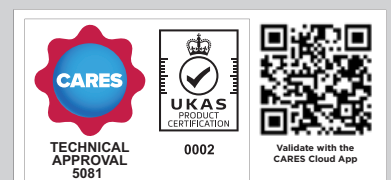

4 Installation

The bars to be threaded must be cut square and threaded, using LENTON equipment and suitably trained and experienced operatives in accordance with LENTON operating instructions. These operators will have received LENTON equipment training.

It is essential that the joints be tightened to the correct torque mentioned in the installation manual, using the appropriate LENTON torque wrench.

4.1 LENTON A2(N) Standard Couplers

A2(N) Standard Couplers are for connecting same size diameter reinforcing bars where one of the bars forming the splice is free to turn. The parts are screwed together by hand and tightened to the correct torque. Where the coupler forms a stop end, it must be torque tightened to the reinforcing bar. When the joint is to be made the continuation bar is screwed into the coupler by hand and tightened to the correct torque. The continuation bar must be able to rotate freely.

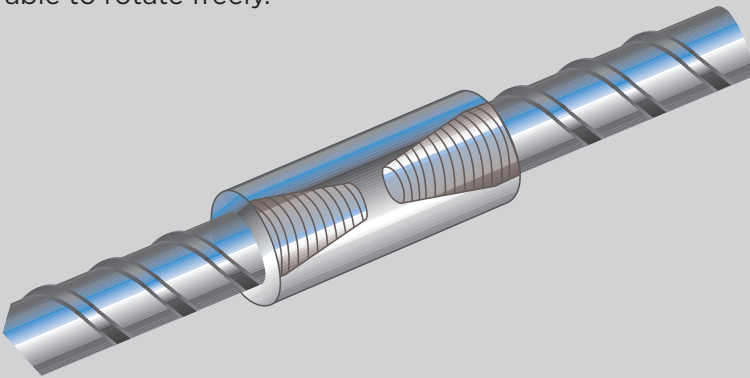

A2(N) Coupler

4.2 LENTON A2(N) Standard Transition Couplers

A2(N) Standard Transition Couplers are for connecting different diameter reinforcing bars where one of the bars forming the splice is free to turn. The parts are screwed together by hand and tightened to the correct torque. Where the coupler forms a stop end, it must be torque tightened to the reinforcing bar. When the joint is to be made the continuation bar is screwed into the coupler by hand and tightened to the correct torque. The continuation bar must be able to rotate freely.

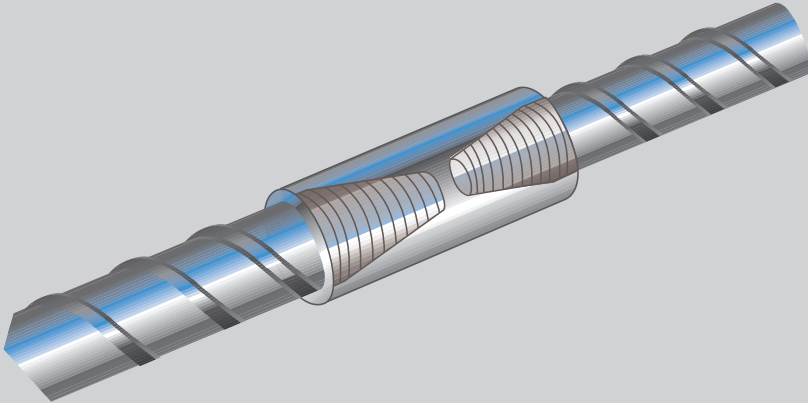

A2(N) Standard Transition Coupler

4.3 LENTON P14LN Position Couplers

P14LN couplers are for connecting onto a bent bar or a bar that cannot be rotated. It must be ensured that the male part is fully screwed into the female part and the female part is tightened onto the first bar. The taper-threaded bent bar is inserted into the mouth of the coupler as far as possible. The male part is screwed out of the female part to engage the taper-threaded bar and is tightened. The lock-nut is spun back to the coupler body and fully tightened against the coupler body after setting the bent bar to the required position. It must be ensured that the limit groove is not fully visible above the lock-nut.

5 Safety Considerations

Care must be taken in handling and installing couplers. Couplers are supplied in containers that have a maximum weight of 25kg. Protective gloves should be worn when handling the containers, threaded bars and installing the couplers.

6 Product Testing and Evaluation

LENTON A2(N) and P14LN Couplers have been tested to satisfy the requirements of CARES Appendix TA1-F for Couplers with reinforcing bars to BS4449 Grade B500B as appropriate. The testing comprised the following elements:

- Tensile Strength
- Ductility
- Permanent deformation in tension

Tests verify compliance with Clauses 5.3 and 5.4 of ISO15835-1:2018 for tensile strength, ductility and slip under static forces.

7 Quality Assurance

LENTON A2(N) and P14LN Couplers for reinforcing steel are produced under a BS EN ISO9001 quality management system certified by CARES at locations agreed with CARES.

The quality management system scheme monitors the production of the Standard and Standard Transition Couplers and ensures that materials and geometry remain within the limits of this technical approval.

The products are subject to a programme of periodic testing to ensure continued compliance.

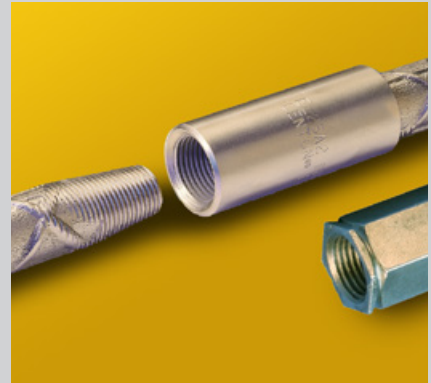

8 Materials and Workmanship

This technical approval gives assurance that the LENTON A2(N) and P14LN Couplers to reinforcing steel comply with the material requirements of EC2.

9 References

- BS4449: 2005 Steel bars for the reinforcement of and use in concrete - Requirements and test methods.
- ISO15835-1:2018 Steels for the reinforcement of concrete - Reinforcement couplers for mechanical splices of bars - Part 1: Requirements.
- BS EN 1992-1-1:2004 Eurocode 2 Design of concrete structures - General rules for buildings.
- BS EN ISO 9001: Quality management systems - Requirements.
- CARES Appendix TA1-F: Quality and Operations Schedule for the Technical Approval of Couplers for high cycle fatigue and low cycle loading and static loading applications in tension.



10 Conditions

1. The quality of the materials and method of manufacture have been examined by CARES and found to be satisfactory. This technical approval will remain valid providing that:
 - a. The product design and specification are unchanged.
 - b. The materials, method of manufacture and location are unchanged.
 - c. The manufacturer complies with CARES regulations for technical approvals.
 - d. The manufacturer holds a valid CARES Certificate of Product Assessment.
 - e. The product is installed and used as described in this report.
2. CARES make no representation as to the presence or absence of patent rights subsisting in the product and/or the legal right of ERICO Europe to market the product.
3. Any references to standards, codes or legislation are those which are in force at the date of this certificate.
4. Any recommendations relating to the safe use of this product are the minimum standards required when the product is used. These requirements do not purport to satisfy the requirements of the Health and Safety at Work act 1974 or any other relevant safety legislation.
5. CARES does not accept any responsibility for any loss or injury arising as a direct or indirect result of the use of this product.
6. This Technical Approval Report should be read in conjunction with CARES Certificate of Product Assessment No 5081. Confirmation that this technical approval is current can be obtained from CARES.



Electronic Copy www.carescertification.com

CARES

Pembroke House
21 Pembroke Road
Sevenoaks
Kent TN13 1XR

Phone: +44(0)1732 450000
E-mail: general@carescertification.com
www.carescertification.com



**Independent Product Assessments
for the Construction Industry**

Copyright CARES ©