

CADDY ROD LOCK Beam Clamp

Part Number	Article Number	Description	RS	T	F*	Max. Pipe diameter supported by clamp & threaded rod **
CRLB50EG	N/A	1/2" CADDY ROD LOCK Beam Clamp	1/2"	3/8" - 3/4"	1,100 lbs	8"/DN200
CRLBM12EG	390023	M12 CADDY ROD LOCK Beam Clamp	M12	9.5mm - 20mm	4,400 N	8"/DN200

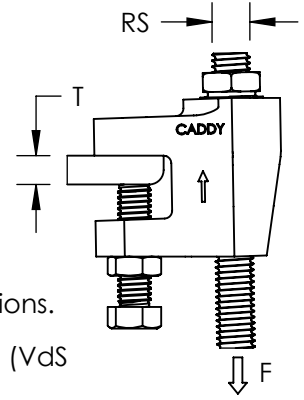

*CRLB50EG and CRLBM12EG Beam Clamps are listed per UL® 2239 in Method #1 & #2 orientations.
 *Load rating for MSS and general applications with 3.5 safety factor.
 **CRLBM12EG Beam Clamp is VdS approved when installed in Method #1 and #2 orientations. (VdS approval number G412036)

CADDY ROD LOCK beam clamp are not for use with hot dip galvanized threaded rod.

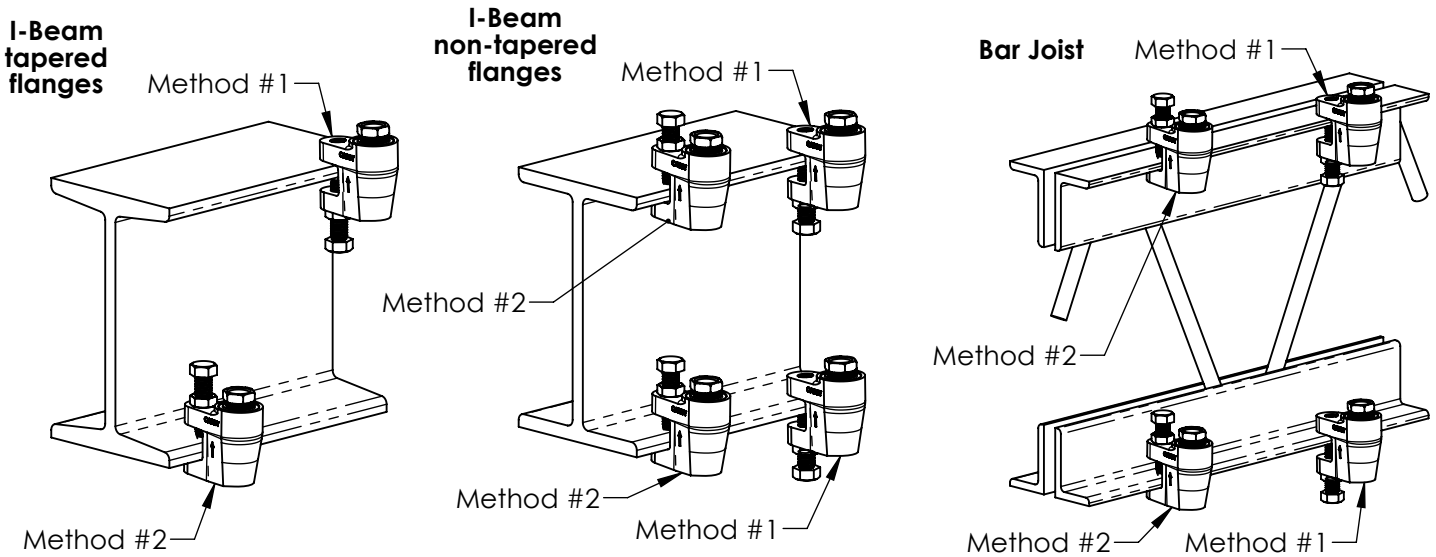

WARNING:

1. Pentair products shall be installed and used only as indicated in Pentair product instruction sheets and training materials. Instruction sheets are available at www.erico.pentair.com and from your Pentair customer service representative.
2. PENTAIR products must never be used for a purpose other than the purpose for which they were designed or in a manner that exceeds specified load ratings.
3. All instructions must be completely followed to ensure proper and safe installation and performance.
4. Improper installation, misuse, misapplication or other failure to completely follow Pentair's instructions and warnings may cause product malfunction, property damage, serious bodily injury and/or death, and void your warranty.
5. Products that are manufactured using spring steel components shall be used only in a non-corrosive indoor environment.
6. All pipe supports, hangers, intermediate components and structural attachments must ONLY be used as described herein and are NEVER to be used for any other purpose.

NOTE: All load ratings are for static conditions and do not account for dynamic loading such as wind, water or seismic loads, unless otherwise noted.

The customer is responsible for:

- a. Conformance to all governing codes.
- b. The integrity of structures to which the products are attached, including their capability of safely accepting the loads imposed, as evaluated by a qualified engineer.
- c. Using appropriate industry standard hardware as noted above.

SAFETY INSTRUCTIONS:

All governing codes and regulations and those required by the job site must be observed.
 Always use appropriate safety equipment such as eye protection, hard hat, and gloves as appropriate to the application.



Pentair, CADDY, ERICO CADWELD, ERICO CRITEC, ERICO, ERIFLEX, and LENTON are owned by Pentair or its global affiliates. All other trademarks are the property of their respective owners. Pentair reserves the right to change specifications without prior notice.

Method #1

*Arrows on CADDY ROD LOCK Beam Clamps must always point up.

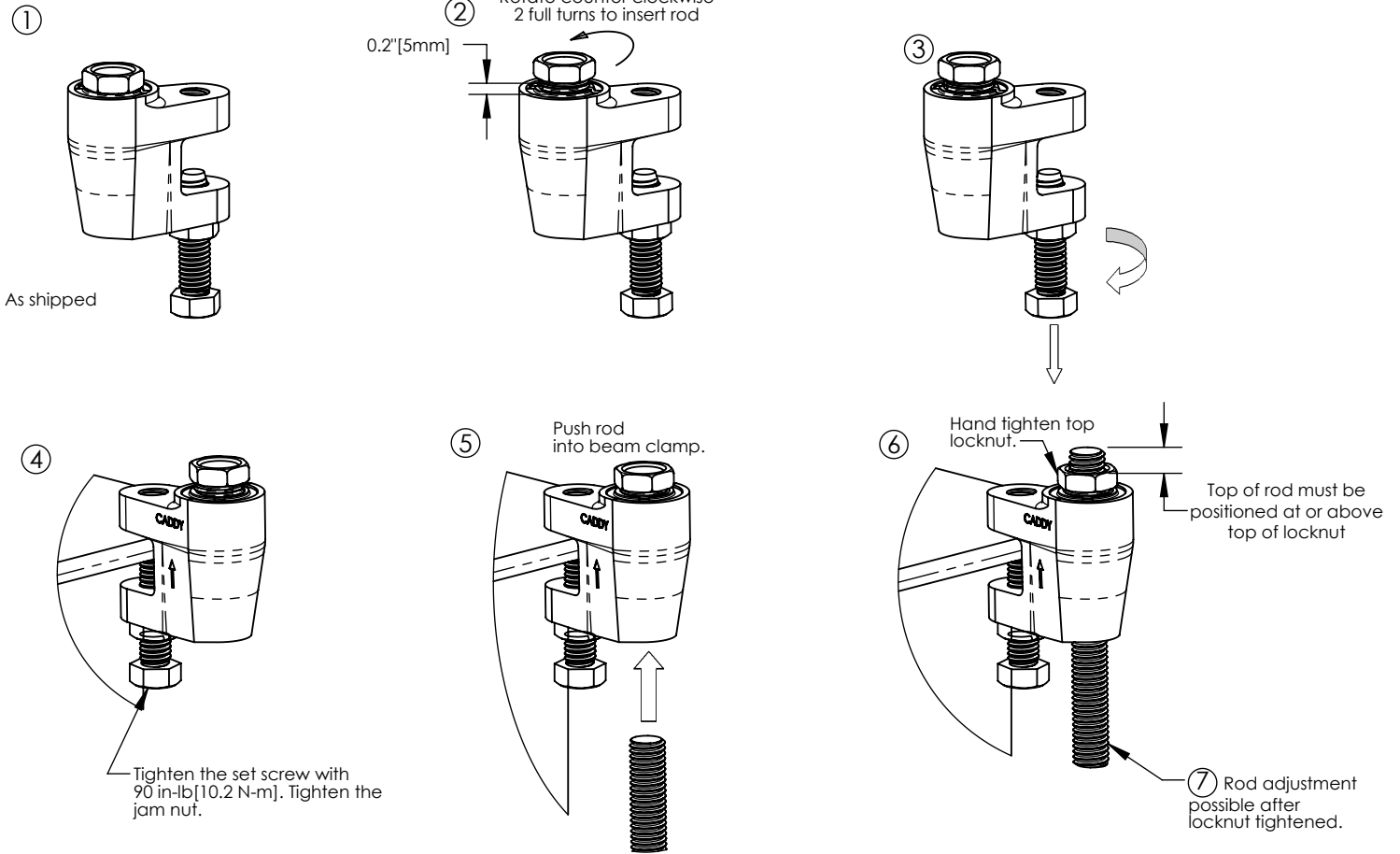

Method #2

*Arrows on CADDY ROD LOCK Beam Clamps must always point up.

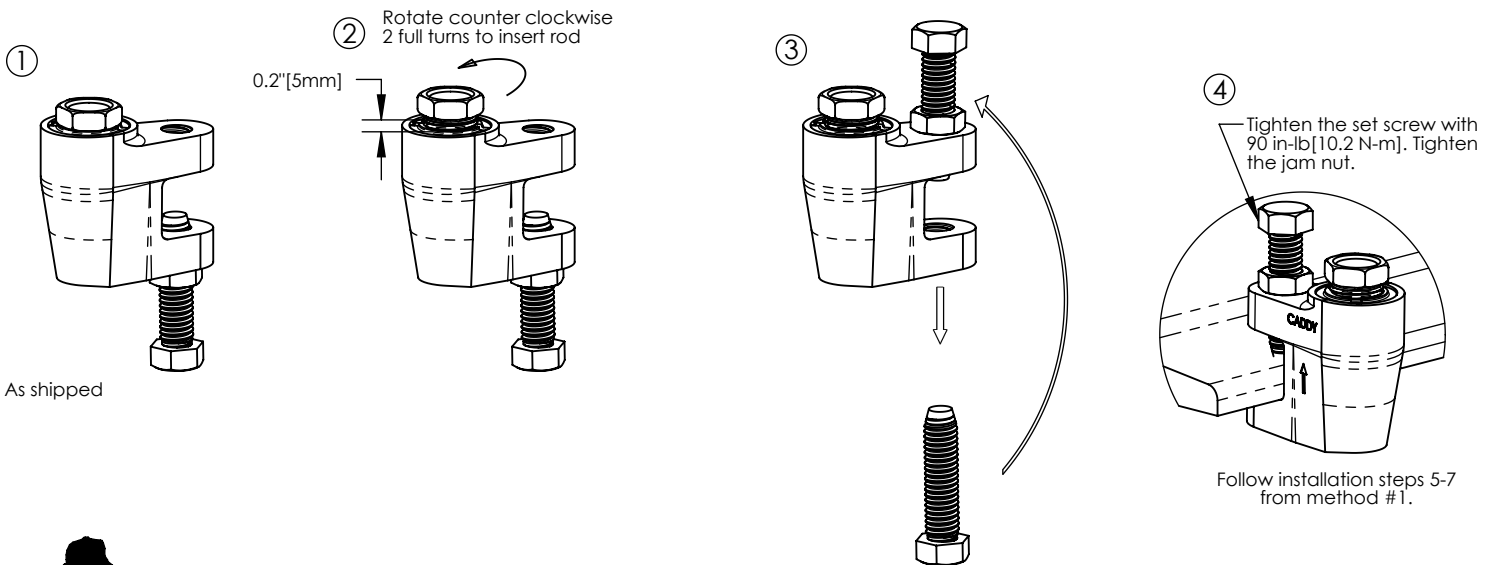

Pentair, CADDY, ERICO CADWELD, ERICO CRITEC, ERICO, ERIFLEX, and LENTON are owned by Pentair or its global affiliates. All other trademarks are the property of their respective owners. Pentair reserves the right to change specifications without prior notice.