

ERICO® CADWELD®

Type "VV" connection

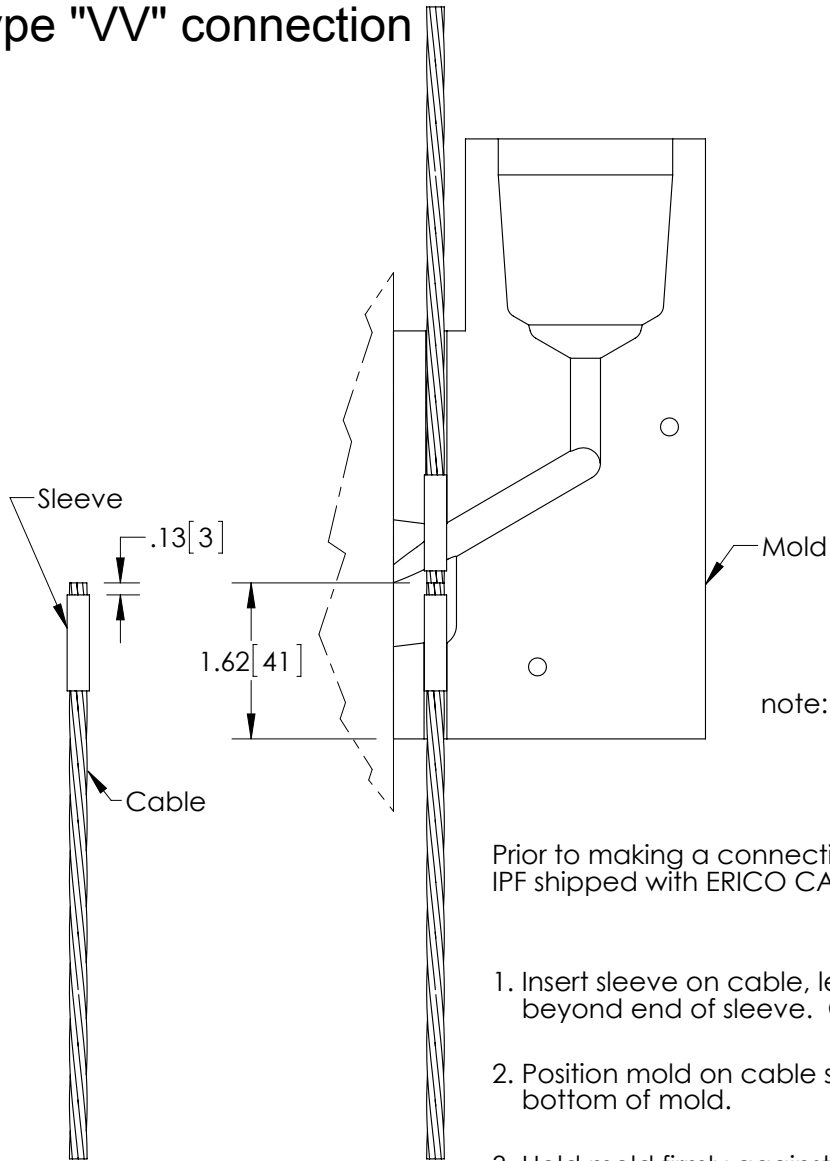

note: Mold half, cover and clamp handle #L160 removed for clarity.

All Dimensions are in Inch [mm]

Prior to making a connection, read and follow the full instruction sheet IPF shipped with ERICO CADWELD mold and special instructions below.

1. Insert sleeve on cable, letting end protrude .06[2] to .13[3] beyond end of sleeve. Crimp ends to prevent sleeve sliding off cable.
2. Position mold on cable so that ends of cables are 1.62 [41] inch from bottom of mold.
3. Hold mold firmly against steel surface.

WARNING:

1. ERICO products shall be installed and used only as indicated in ERICO product instruction sheets and training materials. Instruction sheets are available at www.erico.com and from your ERICO customer service representative.
2. ERICO products must never be used for a purpose other than the purpose for which they were designed or in a manner that exceeds specified load ratings.
3. All instructions must be completely followed to ensure proper and safe installation and performance.
4. Improper installation, misuse, misapplication or other failure to completely follow ERICO's instructions and warnings may cause product malfunction, property damage, serious bodily injury and death.

SAFETY INSTRUCTIONS:

All governing codes and regulations and those required by the job site must be observed. Always use appropriate safety equipment such as eye protection, hard hat, and gloves as appropriate to the application.



CADDY, CADWELD, CRITEC, ERICO, ERIFLEX, ERITECH, and LENTON are registered trademarks of ERICO International Corporation.