

TDSGAPC14

Pipe Mount Grounding Bus

Pipe Size Range: 1.9 to 2.5 inch actual diameter
(1.5 to 2 inch, Schedule 40)

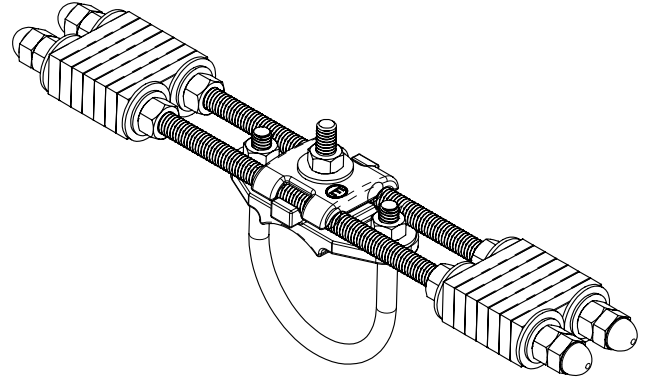

Clean surface of pipe using a T313 wire brush. Remove all paint and oxide layers.

Attach clamp to pipe. Tighten hex nuts on U-bolt.

Apply anti-oxide compound at interface

5/16-18 Hex Nut
Apply 12 ft-lbs (Max)

Install threaded rods by loosening hex nut on connector. Snug hex nut by hand such that the rods do not fall from the connector. Do not tighten hex nut.

Loosen to install rods

Install inner hardware.

3/8 Hex Nut

3/8 Belleville Washer

3/8 Flat Washer

WARNING:

1. ERICO products shall be installed and used only as indicated in ERICO product instruction sheets and training materials. Instruction sheets are available at www.erico.com and from your ERICO customer service representative.
2. ERICO products must never be used for a purpose other than the purpose for which they were designed or in a manner that exceeds specified load ratings.
3. All instructions must be completely followed to ensure proper and safe installation and performance.
4. Improper installation, misuse, misapplication or other failure to completely follow ERICO's instructions and warnings may cause product malfunction, property damage, serious bodily injury and death.

SAFETY INSTRUCTIONS:

All governing codes and regulations and those required by the job site must be observed. Always use appropriate safety equipment such as eye protection, hard hat, and gloves as appropriate to the application.

CADDY, CADWELD, CRITEC, ERICO, ERIFLEX, ERITECH, and LENTON are registered trademarks of ERICO International Corporation.



Install lugs and spacers. Crimp lugs and wires together prior to install. Apply anti-oxide compound to both sides of each lug.

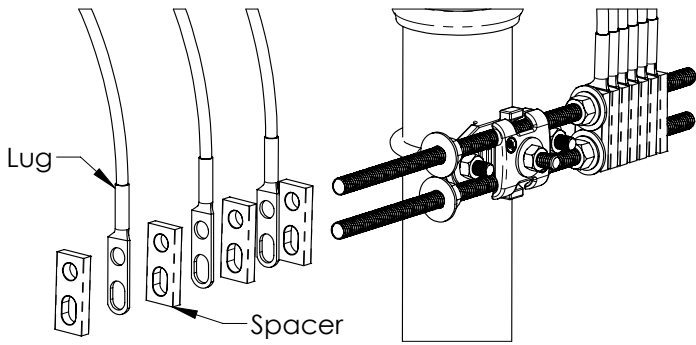

Maximum Lug Size: 6 AWG, two-hole lugs

Install outer hardware. Do not tighten.

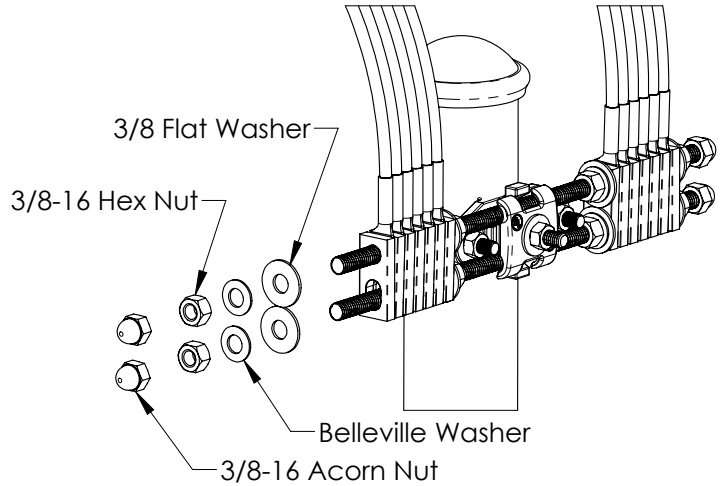

Tighten hex nut on rod connector.

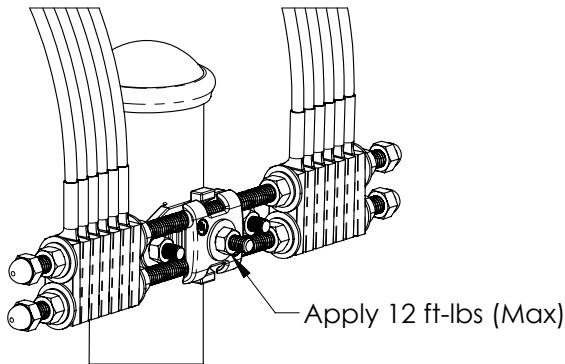

Note: In the absence of a torque wrench, snug bolt and tighten 1/4-turn.

Tighten inner and outer hardware.

Apply 20 ft-lbs (max)

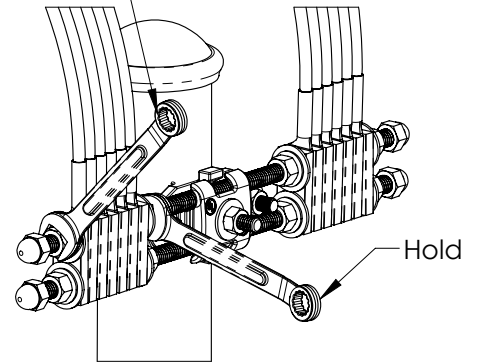

Note: In the absence of a torque wrench, snug bolt and tighten 1/4-turn.

The grounding bus must be electrically connected to the grounding system. Down-conductors may be used to connect the grounding bus to the grounding system (6 AWG or larger). When using a CADWELD® exothermic connection to connect the structure to the grounding system, remove the galvanized coating prior to welding.

After installation and welding are complete, cover exposed steel with cold galvanized coating (T372A, T358 or equivalent) if attached to a galvanized steel pipe.

